

Rec'd 4-20-2000

WESTERMAN ALLOTMENT NO. 2
PLAT CABINET A. SLIDE 609

LOT 4421

LOT 4429

S 83° 10' 09" E
168.02'

S 83° 10' 09" E
120.59'
10' UTILITY EASEMENT

LOT 4353

LOT 4354

LOT 4373

N 05° 59' 00" E
100.00'

S 05° 59' 00" W
100.00'

HEATHER HILL DRIVE (60')

35' SETBACK LINE

10' UTILITY EASEMENT

120.59' 5' UTILITY EASEMENT

N 83° 10' 09" W
120.59' 5' UTILITY EASEMENT

LOT 4355

WESTERMAN ALLOTMENT NO. 1
PLAT CABINET A. SLIDE 587

LOT 4372

17.5' SETBACK LINE

RESERVOIR ROAD

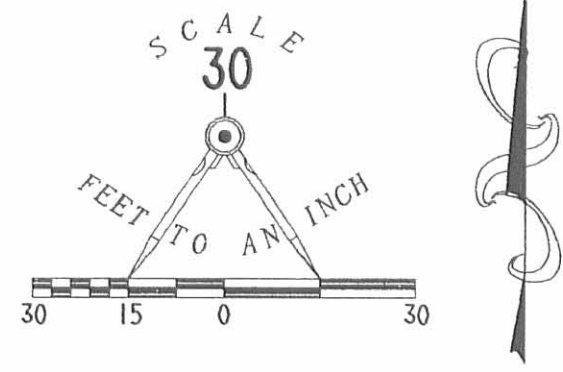

LEGEND

- 5/8 INCH IRON ROD SET
- CONCRETE MONUMENT FOUND

RETRACEMENT SURVEY OF LOT 4373
OF WESTERMAN ALLOTMENT NO. 1
PLAT CABINET A. SLIDE 587
VIRGINIA MILITARY SURVEY 4478
CITY OF BELLEFONTAINE
LAKE TOWNSHIP
LOGAN COUNTY, OHIO



SURVEYED BY:
Jeffrey I. Lee
JEFFREY I. LEE
PROFESSIONAL SURVEYOR 6359
APRIL 13, 2000

COPYRIGHT 2000 BY:
LEE SURVEYING & MAPPING CO., INC.
117 North Madriver Street
BELLEFONTAINE, OHIO 43311
(937) 593-7335

ORIGINAL STAMP IN GREEN

D 372 KERNS

L-2943-3

2 WORKING DAYS
BEFORE YOU DIG
CALL TOLL FREE **800-362-2764**
OHIO UTILITIES PROTECTION SERVICE.

INDEXED ON MAP
5970 1P

DEDICATION

BEING THE SOLE OWNERS OF THE HEREIN DESCRIBED PREMISES, WE DEDICATE THE RIGHT OF WAY AS SHOWN FOR THE WIDENING OF RESERVOIR ROAD AND THE CREATION OF HEATHER HILL DRIVE.

WE ALSO DEDICATE UTILITY EASEMENTS AS SHOWN AND DESCRIBED AS FOLLOWS:

BEING 10 FEET IN WIDTH, BEING PARALLEL WITH AND ADJACENT TO THE ENTIRE PERIMETER OF THE ALLOTMENT.

BEING 5 FEET IN WIDTH, PARALLEL WITH AND ADJACENT TO EACH SIDE OF ALL SIDE (INTERIOR) LOT LINES.

ONE 20 FOOT WIDE EASEMENT AS SHOWN.

Richard E. Westerman
Sandy Westerman
 OWNERS:

Bernice E. Deane
Angela E. Deane
 WITNESS:

ACKNOWLEDGEMENT

COUNTY OF LOGAN, STATE OF OHIO SS

BEFORE ME, A NOTARY PUBLIC IN AND FOR SAID COUNTY AND STATE, DID PERSONALLY APPEAR THE ABOVE SIGNED OWNERS WHO ACKNOWLEDGED THE SIGNING OF THIS DOCUMENT, TO BE THEIR FREE ACT AND DEED. IN TESTIMONY THEREOF I AFFIX MY HAND AND SEAL THIS 12th DAY OF September 1974.

Bernice E. Deane
 NOTARY PUBLIC MY COMMISSION EXPIRES October 30 1976

APPROVALS

APPROVED BY THE CITY PLANNING COMMISSION OF THE CITY OF BELLEFONTAINE, OHIO THIS _____ DAY OF _____ 1974

CHAIRMAN CITY PLANNING COMMISSION

THE ACCOMPANYING PLAT WAS ACCEPTED BY ORDINANCE NO. _____ AS AN ADDITION TO THE CITY OF BELLEFONTAINE, OHIO AT A REGULAR MEETING OF THE CITY COUNCIL ON THE _____ DAY OF _____ 1974.

MAYOR _____ PRESIDENT OF COUNCIL _____ CLERK OF COUNCIL _____

THE WITHIN LOTS TRANSFERED THIS _____ DAY OF _____ 1974.

AUDITOR, LOGAN COUNTY, OHIO

RECEIVED FOR RECORD THIS _____ DAY OF _____ 1974 AT _____ O'CLOCK _____ M. IN THE OFFICE OF THE LOGAN COUNTY RECORDER AND RECORDED IN PLAT BOOK _____ PAGE _____

RECORDER, LOGAN COUNTY, OHIO



WESTERMAN ALLOTMENT I
 V.M.S. 4478, LAKE TOWNSHIP
 CITY OF BELLEFONTAINE, LOGAN COUNTY, OHIO

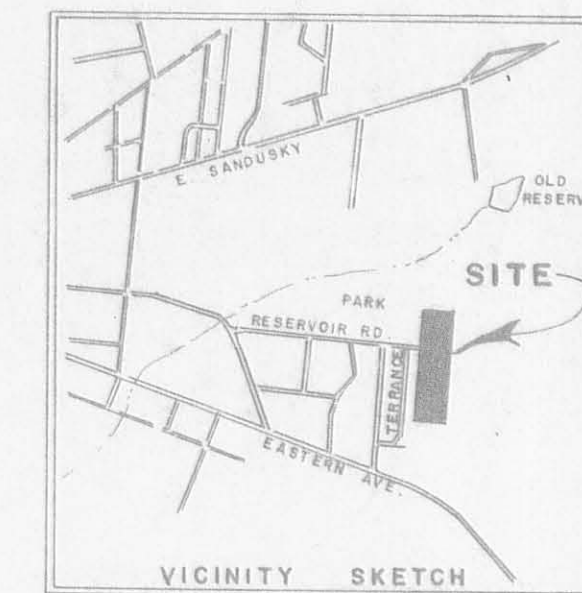

CERTIFICATION

I HEREBY CERTIFY THAT THIS PLAT IS A CORRECT REPRESENTATION OF A SURVEY MADE BY ME AND THAT ALL MONUMENTS SHOWN THEREON ACTUALLY EXIST, THAT THEIR LOCATIONS ARE CORRECTLY SHOWN AND THAT ALL REQUIREMENTS OF THE SUBDIVISION REGULATIONS OF THE CITY OF BELLEFONTAINE HAVE BEEN COMPLIED WITH.

DESCRIPTION

BEGINNING AT THE SOUTHEAST CORNER OF LOT 4299, THENCE WITH THE EAST LINE OF LOT 4299 N. 6° 10' E. 200.00 FEET TO AN IRON PIN; THENCE S. 84° 15' E. 358.20 FEET TO AN IRON PIN; THENCE S. 5° 59' W. 232.50 FEET TO AN IRON PIN ON THE CENTERLINE OF RESERVOIR ROAD; THENCE S. 5° 49' W. 743.29 FEET TO A IRON BAR, THENCE N. 83° 36' W. 298.43 FEET TO A POST; THENCE N. 5° 40' E. 772.44 FEET TO AN IRON PIN ON THE NORTH RIGHT OF WAY LINE OF RESERVOIR ROAD; THENCE WITH SAID RIGHT OF WAY N. 84° 15' W. 58.20 FEET TO THE POINT OF BEGINNING.

CONTAINING 6.97 ACRES, MORE OR LESS, OF WHICH 1.62 ACRES IS PLATTED IN STREETS AND 5.35 ACRES IS IN LOTS.

Larry E. Blosser
 LARRY E. BLOSSER S.I.T. 1199
 R.R. 2
 BELLEFONTAINE, OHIO

Daniel E. Gilbert
 DANIEL E. GILBERT REGISTERED P.S. 5402
 1041 N. MAIN ST.
 BELLEFONTAINE, OHIO

APPROVED THIS _____ DAY OF _____ 1974.

CITY ENGINEER
 CITY OF BELLEFONTAINE, OHIO

PLAT SCALE 1" = 50'

NOTE: DESIGNATES IRON PIN - MONUMENTS SET

STORM WATER DRAINAGE EASEMENT RECORDED
 DEED BOOK 355, PAGE 181 & 182