

1
RECID 2-9-04 SMJ DL

Lee Surveying and Mapping Co., Inc.

Land Surveys • Topography • Subdivisions • Construction Layout

117 N. Madriver St.
Bellefontaine OH 43311



Phone: (937) 593-7335
Fax: (937) 593-7444

MAIN BELLE LLC. 0.429 ACRE

Lying in Section 32, Town 4, Range 14, Liberty Township, City of Bellefontaine, Logan County, Ohio

Being out of the Main Belle LLC. original 1.836 acre tract as deeded and described in Official Record 674, Page 845 of the Logan County Records of Deeds and being more particularly described as follows:

Beginning at the railroad spike found at the intersection of center-lines of South Main Street (80 feet wide) and Gunntown Road (60 feet wide).

THENCE, with the center-line of U.S. Route 68, S 4°-10'-00"E, a distance of 222.16 feet to a P.K. nail found.

THENCE, with the north line of the City of Bellefontaine 0.190 acre tract (O.R. 291, Pg. 557), S 85°-50'-00"W, a distance of 40.00 feet to a 5/8 inch iron rod found.

THENCE, with the west line of the said 0.190 acre tract, S 4°-10'-00"E, a distance of 127.68 feet to a 5/8 inch iron rod set at THE TRUE POINT OF BEGINNING.

THENCE, with the west line of the said 0.190 acre tract, S 4°-10'-00"E, a distance of 55.50' to a 5/8 inch iron rod found.

THENCE, with a north line of the DDR Continental LP 8.403 acre tract (O.R. 358, Pg.183 Parcel I, Tract I), S 85°-50'-00"W, a distance of 180.00 to a 5/8 inch iron rod found.

THENCE, with the east line of the said 8.403 acre tract the following 2 courses.

1.) With a curve to the right having a central angle of 90°-00'-01", a radius of 10.00 feet, an arc length of 15.71 feet, a chord bearing of N 49°-10'-00"W, a distance of 14.14 feet to a 5/8 inch iron rod found.

2.) N 4°-10'-00"W, a distance of 115.19 feet to a MAG nail set.

THENCE, N 85°-50'-00"E, a distance of 117.00 feet to a point.

THENCE, S 4°-10'-00"E, a distance of 69.68 feet to a point.

THENCE, N 85°-50'-00"E, a distance of 73.00 feet to the point of beginning.

Containing 0.429 acre.

The basis for bearings is the center-line of South Main Street being S 4°-10'-00"E, and all other bearings are from angles and distances measured in a field survey by Lee Surveying and Mapping Co., Inc. on January 29, 2004.



ORIGINAL STAMP IN GREEN

Description prepared by:

A handwritten signature in black ink that reads 'William K. Bruce'.

William K. Bruce
Professional Surveyor 7437
February 3, 2004

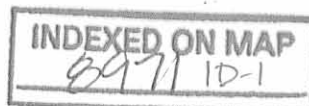

37110104

REC'D 2-9-04 SAM AL

Lee Surveying and Mapping Co., Inc.

Land Surveys • Topography • Subdivisions • Construction Layout

117 N. Madriver St.
Bellefontaine OH 43311



Phone: (937) 593-7335
Fax: (937) 593-7444

MAIN BELLE LLC. 0.370 ACRE

Lying in Section 32, Town 4, Range 14, Liberty Township, City of Bellefontaine, Logan County, Ohio

Being out of the Main Belle LLC. original 1.836 acre tract as deeded and described in Official Record 674, Page 845 of the Logan County Records of Deeds and being more particularly described as follows:

Beginning at the railroad spike found at the intersection of center-lines of South Main Street (80 feet wide) and Gunntown Road (60 feet wide).

THENCE, with the center-line of U.S. Route 68, S 4°-10'-00"E, a distance of 222.16 feet to a P.K. nail found.

THENCE, with the north line of the City of Bellefontaine 0.190 acre tract (O.R. 291, Pg. 557), S 85°-50'-00"W, a distance of 40.00 feet to a 5/8 inch iron rod found at THE TRUE POINT OF BEGINNING.

THENCE, with the west line of the said 0.190 acre tract, S 4°-10'-00"E, a distance of 127.68 feet to a 5/8 inch iron rod set.

THENCE, S 85°-50'-00"W, a distance of 73.00 feet to a point.

THENCE, N 4°-10'-00"W, a distance 69.68 feet to a point.

THENCE, S 85°-50'-00"W, a distance of 117.00 feet to a MAG nail set.

THENCE with the east line of the DDR CONTINENTAL LP 8.403 acre tract (O.R. 358, Pg. 183 Parcel I, Tract I) N 4°-10'-00"W, a distance of 58.00 feet to a 5/8 inch iron rod found.

THENCE, N 85°-50'-00"E, a distance of 190.00 feet to the point of beginning.

Containing 0.370 acre.

The basis for bearings is the center-line of South Main Street (U.S. Route 68) being S 4°-10'-00"E, and all other bearings are from angles and distances measured in a field survey by Lee Surveying and Mapping Co., Inc. on January 29, 2004.

Description prepared by:

A handwritten signature in black ink that reads "William K. Bruce".

William K. Bruce
Professional Surveyor 7437
February 3, 2004



ORIGINAL STAMP IN GREEN

37110104

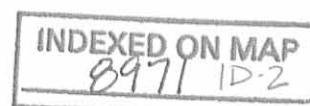

REC'D 29-04 8AM OK
Lee Surveying and Mapping Co., Inc.

Land Surveys • Topography • Subdivisions • Construction Layout

117 N. Madriver St.
Bellefontaine OH 43311

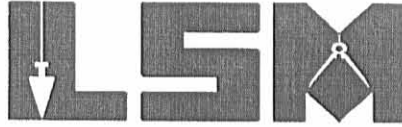

Phone: (937) 593-7335
Fax: (937) 593-7444

**MAIN BELLE LLC.
0.435 ACRE**

Lying in Section 32, Town 4, Range 14, Liberty Township, City of Bellefontaine, Logan County, Ohio

Being out of the Main Belle LLC. original 1.836 acre tract as deeded and described in Official Record 674, Page 845 of the Logan County Records of Deeds and being more particularly described as follows:

Beginning at the railroad spike found at the intersection of center-lines of South Main Street (80 feet wide) and Gunntown Road (60 feet wide).

THENCE, with the center-line of U.S. Route 68, S 4°-10'-00"E, a distance of 94.84 feet to a MAG nail set at THE TRUE POINT OF BEGINNING.

THENCE, with the center-line of U.S. Route 68, S 4°-10'-00"E, a distance of 127.32 feet to a P.K. nail found.

THENCE, S 85°-50'-00"W, a distance of 230.00 feet to a 5/8 inch iron rod found, passing 5/8 inch iron rods found at 30.00 feet and at 40.00 feet.

THENCE, with the east line of the DDR Continental LP 8.403 acre tract (O.R. 358, Pg. 183 Parcel I, Tract I), N 4°-10'-00"W, a distance of 40.00 feet to a MAG nail set.

THENCE, N 85°-50'-00"E, a distance of 118.50 feet to a point.

THENCE, N 4°-10'-00"W, a distance of 87.32 feet to a point.

THENCE, N 85°-50'-00"E, a distance of 111.50 feet to the point of beginning, passing a 5/8 inch iron rod set at 71.50 feet.

Containing 0.435 acre of which 0.117 acre is within the highway right-of-way.

The basis for bearings is the center-line of South Main Street being S 4°-10'-00"E, and all other bearings are from angles and distances measured in a field survey by Lee Surveying and Mapping Co., Inc. on January 29, 2004.

Description prepared by:

A handwritten signature in black ink that reads "William K. Bruce".

William K. Bruce
Professional Surveyor 7437
February 3, 2004



ORIGINAL STAMP IN GREEN

37110104

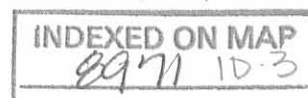

REV'D 2-9-04 SMY AL

Lee Surveying and Mapping Co., Inc.

Land Surveys • Topography • Subdivisions • Construction Layout

117 N. Madriver St.
Bellefontaine OH 43311



Phone: (937) 593-7335
Fax: (937) 593-7444

MAIN BELLE LLC. 0.602 ACRE

Lying in Section 32, Town 4, Range 14, Liberty Township, City of Bellefontaine, Logan County, Ohio

Being out of the Main Belle LLC. original 1.836 acre tract as deeded and described in Official Record 674, Page 845 of the Logan County Records of Deeds and being more particularly described as follows:

Beginning at the railroad spike found at the intersection of center-lines of South Main Street (80 feet wide) and Gunntown Road (60 feet wide).

THENCE, with the center-line of U.S. Route 68, S 4°-10'-00"E, a distance of 36.62 feet to a 5/8 iron rod found at THE TRUE POINT OF BEGINNING.

THENCE, with the center-line of U.S. Route 68, S 4°-10'-00"E, a distance of 58.22 feet to a MAG nail set.

THENCE, S 85°-50'-00"W, a distance of 111.50 feet to a point, passing a 5/8 inch iron rod set at 40.00 feet.

THENCE, S 4°-10'-00"E, a distance of 87.32 feet to a point.

THENCE, S 85°-50'-00"W, a distance of 118.50 feet to a MAG nail set.

THENCE, with the east line of the DDR Continental LP 8.403 acre tract (O.R. 358, Pg. 183 Parcel I, Tract I), N 4°-10'-00"W, a distance of 128.26 feet to a 5/8 inch iron rod found.

THENCE, the following 5 courses with the south line of the Lowe's Home Centers. Inc. 18.322 acre tract (O.R. 284, Pg. 303).

1.) With a curve to the left having a central angle of 12°-46'-18", a radius of 45.00 feet, an arc length of 10.03 feet, a chord bearing N 16°-53'-42"E, a distance of 10.01 feet to a 5/8 inch iron rod found.

2.) With a curve to the right having a central angle of 75°-19'-30", a radius of 30.00 feet, an arc length of 39.44 feet, a chord bearing N 48°-10'-15"E, a distance of 36.66 feet to a 5/8 inch iron rod found.

3.) N 85°-50'-00"E, a distance of 139.04 feet to a 5/8 inch iron rod found.

4.) With a curve to the right having a central angle of 54°-04'-17", a radius of 35.00 feet, an arc length of 33.03 feet, a chord bearing S 67°-07'-52"E, a distance of 31.82 feet to a 5/8 inch iron rod found.

5.) N 85°-50'-00"E, a distance of 30.00 feet to the point of beginning.

Containing 0.602 acre of which 0.055 acre is within the highway right-of-way.

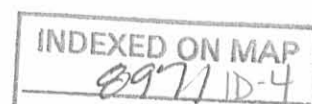

Lee Surveying and Mapping Co., Inc.

Land Surveys • Topography • Subdivisions • Construction Layout

117 N. Madriver St.
Bellefontaine OH 43311



Phone: (937) 593-7335
Fax: (937) 593-7444

The basis for bearings is the center-line of South Main Street being S 4°-10'-00"E, and all other bearings are from angles and distances measured in a field survey by Lee Surveying and Mapping Co., Inc. on January 29, 2004.

Description prepared by:

A handwritten signature in black ink that reads "William K. Bruce".

William K. Bruce
Professional Surveyor 7437
February 3, 2004



ORIGINAL STAMP IN GREEN

37110104

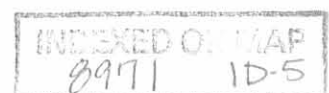

CURVE	DELTA ANGLE	RADIUS	ARC	TANGENT	CHORD	CHORD BEARING
C 1	54°04'17"	35.00'	33.03'	17.86'	31.82'	S 67°07'52"E
C 2	75°19'30"	30.00'	39.44'	23.16'	36.66'	N 48°10'15"E
C 3	12°46'18"	45.00'	10.03'	5.04'	10.01'	N 16°53'42"E
C 4	90°00'01"	10.00'	15.71'	10.00'	14.14'	N 49°10'00"W

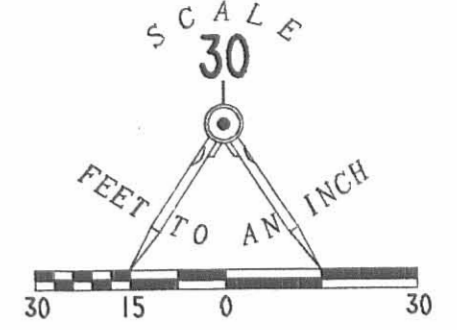

LOWE'S HOME CENTERS, INC.
18.322
O.R. 284, PG. 303

GUNNTOWN ROAD (60' WIDE)

0.602 ACRE
OF WHICH 0.055 ACRE IS
WITHIN THE RIGHT-OF-WAY

0.435 ACRE
OF WHICH 0.117 ACRE IS
WITHIN THE RIGHT-OF-WAY

0.370 ACRE

0.429 ACRE

DDR CONTINENTAL LP
8.403 ACRES
O.R. 358, PG. 183
(PARCEL 1, TRACT 1)

CITY OF BELLEFONTAINE
10' WIDE HIGHWAY
R/W EASEMENT
O.R. 284, PG. 301

CITY OF BELLEFONTAINE
0.190 ACRE
O.R. 291, PG. 557

SOUTH MAIN STREET (80')

- LEGEND
- 5/8 INCH IRON ROD SET
 - 5/8 INCH IRON ROD FOUND
 - ⊙ MAG NAIL SET
 - ⊗ P.K. NAIL FOUND
 - ⊗ RAIL ROAD SPIKE FOUND

A SURVEY OF 4 TRACTS OUT OF THE
MAIN BELLE LLC. 1.836 ACRE TRACT
OFFICIAL RECORD 674, PAGE 845
SECTION. 32, TOWN 4, RANGE 14,
LIBERTY TOWNSHIP
CITY OF BELLEFONTAINE
LOGAN COUNTY, OHIO



SURVEYED BY:

William K. Bruce
WILLIAM K. BRUCE
PROFESSIONAL SURVEYOR 7437
JANUARY 29, 2004

COPYRIGHT 2004 BY:
LEE SURVEYING & MAPPING CO., INC.
117 North Madriver Street
BELLEFONTAINE, OHIO 45311
(937) 593-7335

2 WORKING DAYS
BEFORE YOU DIG
CALL TOLL FREE **800-362-2764**
OHIO UTILITIES PROTECTION SERVICE.

INDEXED ON MAP
8997 IP

Lee Surveying and Mapping Co., Inc.

Land Surveys • Topography • Subdivisions • Construction Layout

117 N. Madriver St.
Bellefontaine OH 43311



Phone: (937) 593-7335
Fax: (937) 593-7444

GOSLEE 1.836 ACRES

Lying in Section 32, Town 4, Range 14, City of Bellefontaine, Liberty Township, Logan County, Ohio.

Being all of the William T. Goslee, Married 1.037 acre tract as deeded and described in Official Record 674, Page 821, and the William T. Goslee, Married 0.799 acre tract as deeded and described in Official Record 674, Page 819, of the Logan County Records of deeds and being more particularly described as follows:

Beginning at a railroad spike found at the intersection of the center-lines of Gunntown Road and South Main Street (width varies).

THENCE, with the center-line of South Main Street, S 4°-10'-00"E, a distance of 36.62 feet to a 5/8 inch iron rod found at the TRUE POINT OF BEGINNING.

THENCE, with the center-line of South Main Street, S 4°-10'-00"E, a distance of 185.54 feet to a P.K. nail found.

THENCE, S 85°-50'-00"W, a distance of 40.00 feet to a 5/8 inch iron rod found.

THENCE, with the west line of the City of Bellefontaine, Ohio, 0.19 acre tract (O.R. 291, Pg. 557), S 4°-10'-00"E, a distance of 183.18 feet to a 5/8 inch iron rod found.

THENCE, with the lines of the Continental Bell, LTD., 8.403 acre tract (O.R. 276, Pg. 579), the following 3 (three) courses:

S 85°-50'-00"W, a distance of 180.00 feet to a 5/8 inch iron rod found.

With a curve to the right having a central angle of 90°-00'-00", a radius of 10.00, an arc length of 15.71', a chord bearing N 49°-10'-00"W, a distance of 14.14 feet to a 5/8 inch iron rod found.

N 4°-10'-00"W, a distance of 341.44 feet to a 5/8 inch iron rod found.

THENCE, with the Lowe's Home Centers, Inc., 18.322 acre tract (O.R. 284, Pg. 303), the following 5 (five) courses:

With a curve to the left having a central angle of 12°-46'-20", a radius of 45.00', an arc length of 10.03', a chord bearing N 16°-53'-39"E, a distance of 10.01 feet to a 5/8 inch iron rod found.

Lee Surveying and Mapping Co., Inc.

Land Surveys • Topography • Subdivisions • Construction Layout

117 N. Madriver St.
Bellefontaine OH 43311



Phone: (937) 593-7335
Fax: (937) 593-7444

With a curve to the right having a central angle of $75^{\circ}-19'-31''$, a radius of 30.00', an arc length of 39.44', a chord bearing $N 48^{\circ}-10'-14''E$, a distance of 36.66 feet to a 5/8 inch iron rod found.

$N 85^{\circ}-50'-00''E$, a distance of 139.04 feet to a 5/8 inch iron rod found.

With a curve to the right having a central angle of $54^{\circ}-04'-18''$, a radius of 35.00', an arc length of 33.03', a chord bearing $S 67^{\circ}-07'-51''E$, a distance of 31.82 feet to a 5/8 inch iron rod found at the right-of-way of South Main Street.

$N 85^{\circ}-50'-00''E$, a distance of 30.00 feet to the point of beginning.

Containing 1.836 acres, of which, 0.128 acre is within the highway right-of-way.

The basis for bearings is the center-line of US Route 68, being $S 4^{\circ}-10'-00''E$, and all other bearings are from angles and distances measured in a field survey by Lee Surveying and Mapping co., Inc. on August 13, 2003

Description prepared by:



ORIGINAL STAMP IN GREEN

Jeffrey I. Lee
Professional Surveyor 6359
August 13, 2003

L-435

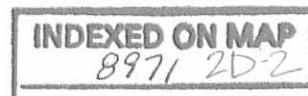

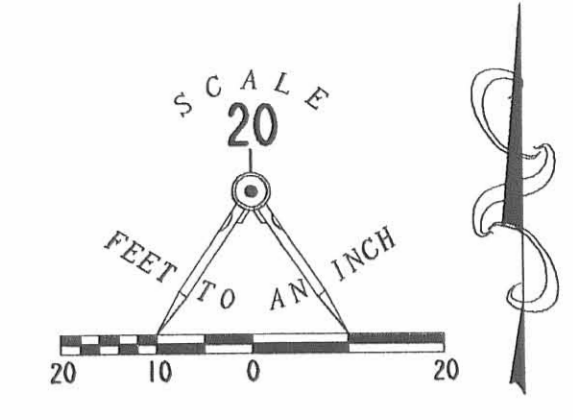

- LEGEND
- 5/8 INCH IRON ROD FOUND
 - ⊗ RAILROAD SPIKE FOUND
 - ⊙ P.K. NAIL FOUND

CURVE	DELTA ANGLE	RADIUS	ARC	TANGENT	CHORD	CHORD BEARING
C 1	90°00'00"	10.00'	15.71'	10.00'	14.14'	N 49°10'00"W
C 2	12°46'20"	45.00'	10.03'	5.04'	10.01'	N 16°53'39"E
C 3	75°19'31"	30.00'	39.44'	23.16'	36.66'	N 48°10'14"E
C 4	54°04'18"	35.00'	33.03'	17.86'	31.82'	S 67°07'51"E

BOUNDARY SURVEY OF
 THE WILLIAM T. GOSLEE, MARRIED
 1.037 ACRE TRACT
 OFFICIAL RECORD 674, PAGE 821
 AND THE WILLIAM T. GOSLEE, MARRIED
 0.799 ACRE TRACT
 OFFICIAL RECORD 674, PAGE 819
 SECTION 32, TOWN 4, RANGE 14
 CITY OF BELLEFONTAINE
 LIBERTY TOWNSHIP
 LOGAN COUNTY, OHIO



SURVEYED BY:

 JEFFREY A. LEE
 PROFESSIONAL SURVEYOR 6359
 AUGUST 13, 2003

COPYRIGHT 1998 BY:
 LEE SURVEYING & MAPPING CO., INC.
 117 North Madriver Street
 BELLEFONTAINE, OHIO 43311
 (937) 593-7335



2 WORKING DAYS
BEFORE YOU DIG
 CALL TOLL FREE 800-362-2764
 OHIO UTILITIES PROTECTION SERVICE

INDEXED ON MAP
 8971 2P

1. RECORD 1-2-96 8/11/00 (OK) JH



Lee Surveying and Mapping Co.



Farm Surveys • Lot Surveys • Topography • Subdivisions • Construction Layout

143 EAST COLUMBUS AVENUE
BELLEFONTAINE, OHIO 43311

(513) 593-7335

JEFFREY L. LEE, P.S.

WILSON ANDERSON SLOPE EASEMENT 0.092 ACRE

Lying in Section 32, Town 4, Range 14, Liberty Township, Logan County, Ohio.

Being a permanent slope easement on the Wilson Anderson original 72.17 acre tract as deeded and described in Volume 390, Page 818 of the Logan County Records of Deeds and being more particularly described as follows:

Beginning at a railroad spike found at the intersection of the north line of Section 32 and the center-line of South Main Street (U.S. Route 68) in the City of Bellefontaine.

THENCE, with the center-line of South Main Street, S 4°-10'-00" E, a distance of 1282.61 feet to a PK nail set.

THENCE, with the north line of a 5.165 acre tract, part of the said 72.17 acre tract, and with a south line of the Venture Properties I, LLC, Ltd. original 9.392 acre tract (O.R. 259, Pg. 828), and a south corporation line of the City of Bellefontaine, S 85°-50'-00" W, a distance of 240.00 feet to the point of beginning.

THENCE, S 4°-10'-00" E, a distance of 20.00 feet to a point.

THENCE, S 85°-50'-00" W, a distance of 200.00 feet to a point.

THENCE, N 4°-10'-00" W, a distance of 20.00 feet to a point referenced by a 5/8 inch iron rod found at a corner of the aforementioned corporation line, S 85°-50'-00" W, a distance of 10.00 feet.

THENCE, with the said corporation line and a south line of the said 9.392 acre tract, N 85°-50'-00" E, a distance of 200.00 feet to the point of beginning.

Containing 0.092 acre.

The basis for bearings is based upon the center-line of South Main Street being S 4°-10'-00" E, and all other bearings are from angles and distances measured in field surveys by Lee Surveying and Mapping Company in December 1995.

Description prepared by:

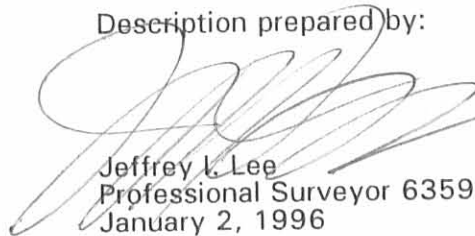
Jeffrey L. Lee
Professional Surveyor 6359
January 2, 1996



L 435

ORIGINAL STAMP IN GREEN

INDEXED ON MAP
8971 3D

REFERENCES

LOGAN COUNTY ENGINEER'S SURVEY RECORDS, DRAWER R, FILE NUMBERS 1638, 777, 2621, 1384, 4314, 3737, AND 2907.

VENTURE PROPERTIES I, LLC LTD
 1.037 ACRES
 O.R. 259, PG. 825

8.403 ACRES

VENTURE PROPERTIES I, LLC, LTD
 ORIG. 9.392 ACRES
 O.R. 259, PG. 828

**SLOPE EASEMENT
 0.092 ACRE**

WILSON ANDERSON
 (5.165 ACRES)
 PART OF THE ORIGINAL 72.17 AC.
 VOL. 390, PG. 818

INDEXED ON MAP
 8971 3P

WILSON ANDERSON
 ORIG. 72.17 AC.
 VOL. 390, PG. 818

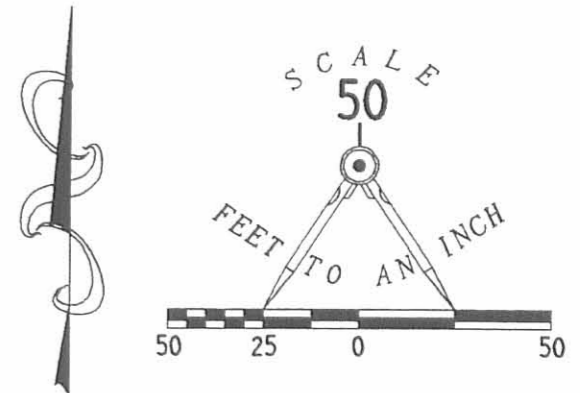

LEGEND

- 5/8" IRON ROD SET W/ PLASTIC I.D. CAP STAMPED "LEE PS6359"
- 5/8" IRON ROD FOUND
- 1" METAL PIPE FOUND
- ⊕ RAILROAD SPIKE SET
- ⊗ RAILROAD SPIKE FOUND
- ⊘ P.K. NAIL SET

**PERMANENT SLOPE EASEMENT
 OUT OF THE WILSON ANDERSON
 ORIGINAL 72.17 ACRE TRACT
 VOLUME 390, PG. 818
 SECTION 32, TOWN 4, RANGE 14
 LIBERTY TOWNSHIP
 LOGAN COUNTY, OHIO**

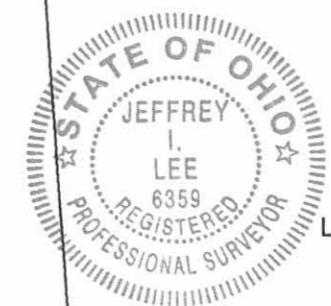

ORIGINAL STAMP IN GREEN

SURVEYED BY:

 JEFFREY I. LEE
 PROFESSIONAL SURVEYOR 6359
 JANUARY 2, 1996

COPYRIGHT 1996 BY:
LEE SURVEYING & MAPPING CO., INC.
 143 East Columbus Avenue
 BELLEFONTAINE, OHIO 43311
 (513) 593-7335

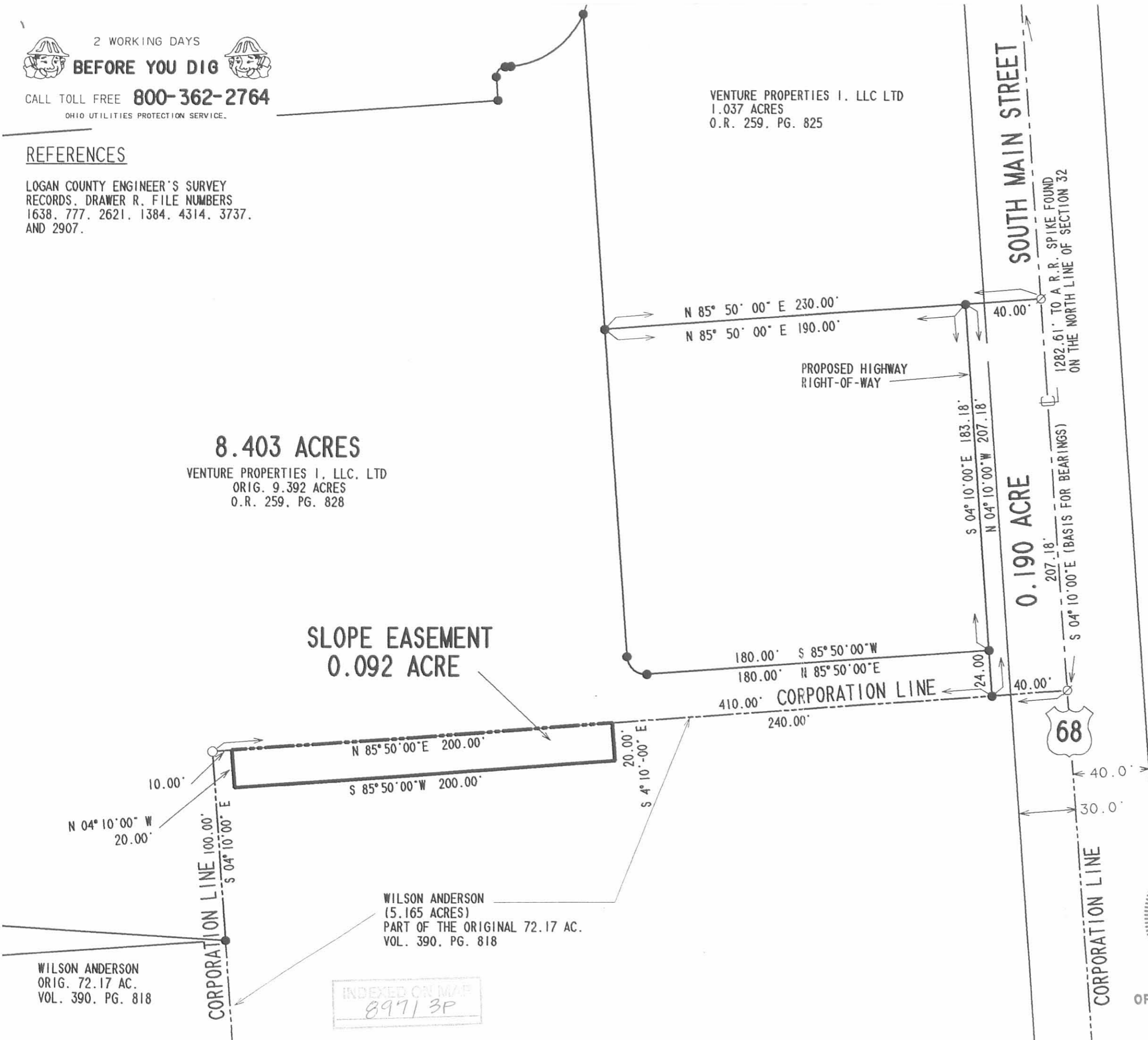

REC'D 7-31-96 JML OK ✓



Lee Surveying and Mapping Co., Inc.



Farm Surveys • Lot Surveys • Topography • Subdivisions • Construction Layout

117 North Madriver Street
Bellefontaine, Ohio 43311

(513) 593-7335
FAX (513) 593-7444

EXHIBIT

CONTINENTAL BELL. LTD. SANITARY SEWER EASEMENT 2

Lying in Section 32, Town 4, Range 14, City of Bellefontaine, Liberty Township, Logan County, Ohio.

Being a 10 feet wide sanitary sewer line easement through the Continental Bell, Ltd. original 8.403 acre tract as deeded and described in Official Record 276, Page 579 of the Logan County Records of Deeds and being more particularly described as follows:

Beginning at a 5/8 inch iron rod set at the southwest corner of the Continental Bell 0.799 acre tract (O.R. 276, Pg. 574) and on a north line of a 24.00 feet wide strip part of the said 8.403 acre tract.

THENCE, S 4°-10'-00" E, a distance of 1.44 feet to the north line of a 10 feet wide sanitary sewer easement.

THENCE, with the north line of the said sanitary sewer easement, S 85°-50'-00" W, a distance of 10.00 feet to a point.

THENCE, N 4°-10'-00" W, a distance of 11.43 feet to a 5/8 inch iron rod set.

THENCE, with a curve to the left having a central angle of 90°-00'-00", a radius of 10.00 feet, having a chord bearing S 49°-10'-00" E, a distance of 14.14 feet to the point of beginning.

The basis for bearings is the center-line of South Main Street being S 4°-10'-00" E, and all other bearings are from records of field surveys by Lee Surveying and Mapping Company in 1995.

Description prepared by:

Jeffrey I. Lee
Professional Surveyor 6359
July 19, 1996.
Revised July 30, 1996



ORIGINAL STAMP IN GREEN

INDEXED ON MAP
89714D-1



Lee Surveying and Mapping Co., Inc.



Farm Surveys • Lot Surveys • Topography • Subdivisions • Construction Layout

117 North Madriver Street
Bellefontaine, Ohio 43311

(513) 593-7335
FAX (513) 593-7444

EXHIBIT

CONTINENTAL BELL. LTD. SANITARY SEWER EASEMENT 1

Lying in Section 32, Town 4, Range 14, City of Bellefontaine, Liberty Township, Logan County, Ohio.

Being a 10 feet wide sanitary sewer line easement through the Continental Bell, Ltd. 0.799 acre tract as deeded and described in Official Record 276, Page 574 of the Logan County Records of Deeds and being more particularly described as follows:

Beginning at a 5/8 inch iron rod set at the northwest corner of the said 0.799 acre tract and on the east line of the Continental Bell, Ltd original 8.403 acre tract (O.R. 276, Pg. 579).

THENCE, with the south line of the Venture Properties I, LLC 1.037 acre tract (O.R. 259, Pg. 825), N 85°-50'-00" E, a distance of 10.00 feet to a point.

THENCE, S 4°-10'-00" E, a distance of 183.18 feet to a 5/8 inch iron rod set.

THENCE, with the lines of the said 8.403 acre tract the following two courses:

With a curve to the right having a central angle of 90°-00'-00", a radius of 10.00 feet, having a chord bearing N 49°-10'-00" W, a distance of 14.14 feet to a 5/8 inch iron rod set.

N 4°-10'-00" W, a distance of 173.18 feet to the point of beginning.

The basis for bearings is the center-line of South Main Street being S 4°-10'-00" E, and all other bearings are from records of field surveys by Lee Surveying and Mapping Company in 1995.

Description prepared by:

Jeffrey I. Lee
Professional Surveyor 6359
July 19, 1996.
Revised July 30, 1996

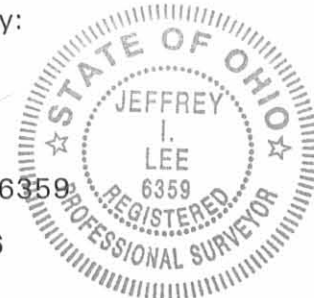

ORIGINAL STAMP IN GREEN

INDEXED ON MAP
897140-2



Lee Surveying and Mapping Co., Inc.



Farm Surveys • Lot Surveys • Topography • Subdivisions • Construction Layout

117 North Madriver Street
Bellefontaine, Ohio 43311

(513) 593-7335
FAX (513) 593-7444

EXHIBIT D

VENTURE PROPERTIES I, LLC NATURAL GAS AND BURIED TELEPHONE LINE EASEMENT

Lying in Section 32, Town 4, Range 14, City of Bellefontaine, Liberty Township, Logan County, Ohio.

Being a 10 feet wide natural gas and buried telephone line easement through the Venture Properties I, LLC 1.037 acre tract as deeded and described in Official Record 259, Page 825 of the Logan County Records of Deeds and being more particularly described as follows:

Beginning at a 5/8 inch iron rod set at the northeast corner of the said 1.037 acre tract and on the west right-of-way of South Main Street (60 feet wide).

THENCE, with the west right-of-way of South Main Street, S 4°-10'-00" E, a distance of 17.04 feet to a point.

THENCE, parallel with the north lines of the aforesaid 1.037 acre tract and 10 feet distant the following five courses:

N 40°-06'-00" W, a distance of 13.80 feet to a point.

With a curve to the left having a central angle of 54°-04'-18", a radius of 25.00 feet, having a chord bearing N 67°-07'-51" W, a distance of 22.73 feet to a point

S 85°-50'-00" W, a distance of 139.04 feet to a point.

With a curve to the left having a central angle of 75°-19'-31", a radius of 20.00 feet, having a chord bearing S 48°-10'-14" W, a distance of 24.44 feet to a point.

With a curve to the right having a central angle of 28°-45'-52", a radius of 55.00 feet, having a chord bearing S 24°-53'-27" W, a distance of 27.32 feet to a point.

THENCE, with the east line of the Continental Bell, Ltd. 8.403 acre tract (O.R. 276, Pg. 579), N 4°-10'-00" W, a distance of 17.08 feet to a 5/8 inch iron rod set.

THENCE, with the south lines of the Lowe's Home Centers, Inc. part of the 18.322 acre tract (O.R. 284, Pg. 303) the following four courses:

With a curve to the left having a central angle of 12°-46'-20", a radius of 45.00 feet, having a chord bearing N 16°-53'-39" E, a distance of 10.01 feet to a 5/8 inch iron rod set.

With a curve to the right having a central angle of 75°-19'-31", a radius of 30.00 feet, having a chord bearing N 48°-10'-14" E, a distance of 36.66 feet to a 5/8 inch iron rod set.

N 85°-50'-00" E, a distance of 139.04 feet to a 5/8 inch iron rod set.

With a curve to the right having a central angle of 54°-04'-18", a radius of 35.00 feet, having a chord bearing S 67°-07'-51" E, a distance of 31.82 feet to the point of beginning.

The basis for bearings is the center-line of South Main Street being S 4°-10'-00" E, and all other bearings are from records of field surveys by Lee Surveying and Mapping Company in 1995.

Description prepared by:

Jeffrey I. Lee
Professional Surveyor 6359
July 19, 1996.
Revised July 30, 1996



ORIGINAL STAMP IN GREEN

INDEXED ON MAP
8971 4D-3

LOWE'S HOME CENTERS, INC.
18.322 ACRES
O.R. 284, PG. 303

VENTURE PROPERTIES I, LLC
1.037 ACRES
O.R. 259, PG. 825

CONTINENTAL BELL, LTD.
8.403 ACRES
O.R. 276, PG. 579

CONTINENTAL BELL, LTD.
0.799 ACRE
O.R. 276, PG. 574

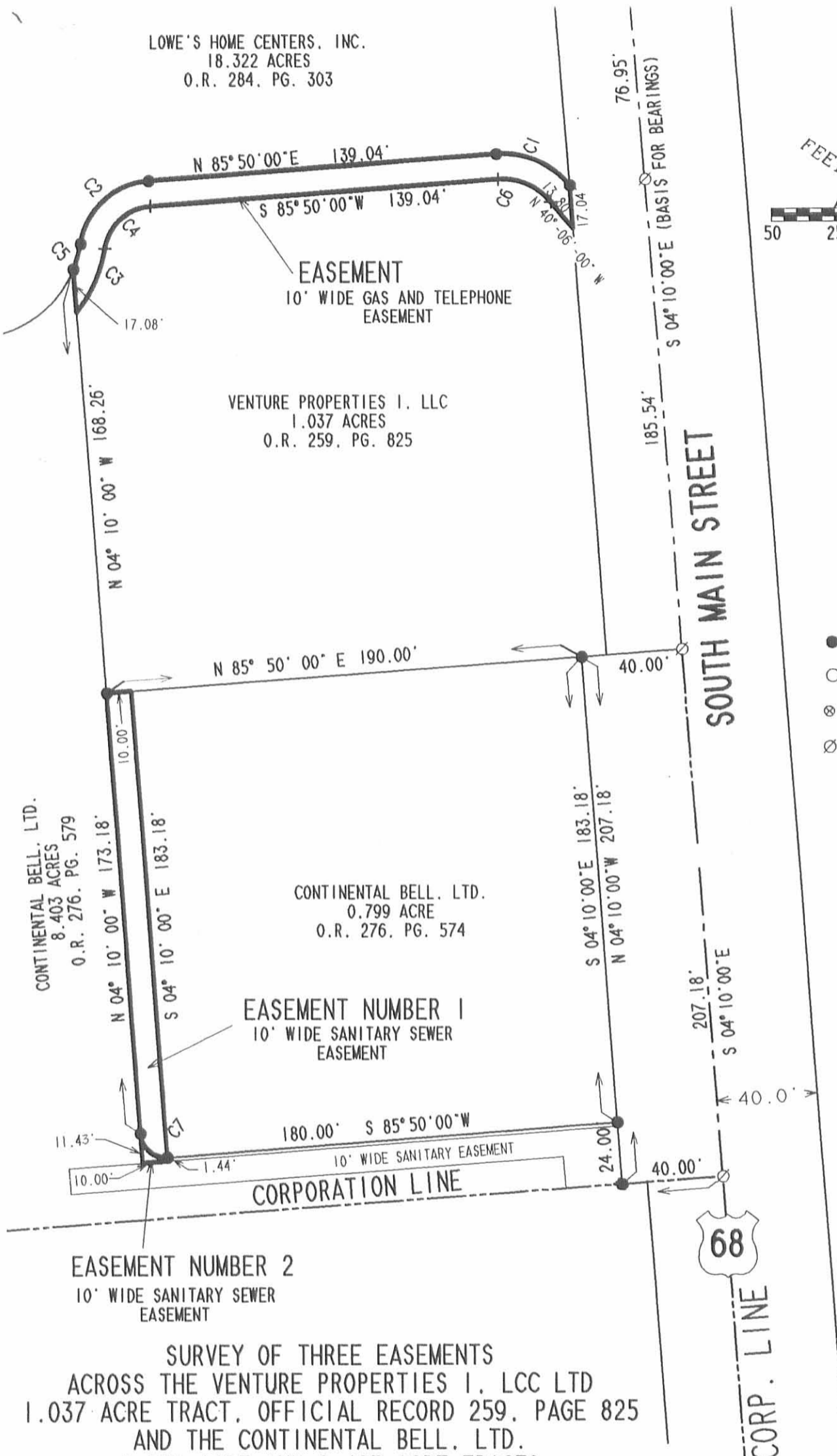
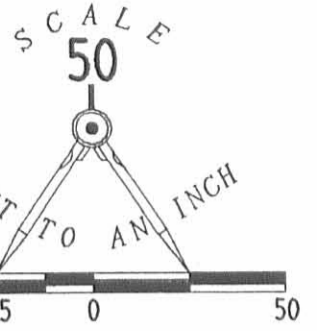

- 5/8" IRON ROD SET
- 5/8" IRON ROD FOUND
- ⊗ RAILROAD SPIKE FOUND
- ⊗ P.K. NAIL SET

CURVE	DELTA	RADIUS	LENGTH	CHORD	CHORD BEARING
C 1	54°04'18"	35.00'	33.03'	31.82'	S 67°07'51"E
C 2	75°19'31"	30.00'	39.44'	36.66'	N 48°10'14"E
C 3	28°45'52"	55.00'	27.61'	27.32'	S 24°53'27"W
C 4	75°19'31"	20.00'	26.29'	24.44'	S 48°10'14"W
C 5	12°46'20"	45.00'	10.03'	10.01'	N 16°53'39"E
C 6	54°04'18"	25.00'	23.59'	22.73'	N 67°07'51"W
C 7	90°00'00"	10.00'	15.71'	14.14'	N 49°10'00"W

**SURVEY OF THREE EASEMENTS
ACROSS THE VENTURE PROPERTIES I, LCC LTD
1.037 ACRE TRACT, OFFICIAL RECORD 259, PAGE 825
AND THE CONTINENTAL BELL, LTD.
0.799 ACRE AND 8.403 ACRE TRACTS
OFFICIAL RECORD 276, PAGES 574 AND 579
SECTION 32, TOWN 4, RANGE 14
CITY OF BELLEFONTAINE
LIBERTY TOWNSHIP
LOGAN COUNTY, OHIO**



SURVEYED BY:
JEFFREY I. LEE
PROFESSIONAL SURVEYOR 6359
JULY 18, 1996
REVISED JULY 30, 1996

COPYRIGHT 1996 BY:
LEE SURVEYING & MAPPING CO., INC.
117 North Madriver Street
BELLEFONTAINE, OHIO 43311
(513) 593-7335

EXHIBIT

INDEXED ON MAP
8971 4P ORIGINAL STAMP IN GREEN



Lee Surveying and Mapping Co., Inc.



Farm Surveys • Lot Surveys • Topography • Subdivisions • Construction Layout

117 NORTH MADRIVER STREET
BELLEFONTAINE, OHIO 43311

(937) 593-7335
FAX (937) 593-7444

EXHIBIT

CONTINENTAL BELL. LTD. 15 FEET WIDE WATER LINE EASEMENT

Lying in Section 32, Town 4, Range 14, City of Bellefontaine, Liberty Township, Logan County, Ohio.

Being a 15 feet wide water line easement through the Continental Bell, Ltd. 0.799 acre tract as deeded and described in Official Record 276, Page 574 of the Logan County Records of Deeds and being more particularly described as follows:

Beginning at a 5/8 inch iron rod set at the southeast corner of the said 0.799 acre tract and on the west right-of-way line of South Main Street, U.S. Route 68 (80 feet wide).

THENCE, with the lines of the Continental Bell, Ltd 8.403 acre tract (O.R. 276, Pg. 579) the following three courses:

S 85°-50'-00" W, a distance of 180.00 feet to a 5/8 inch iron rod set.

With a curve to the right having a central angle of 90°-00'-00", a radius of 10.00 feet, having a chord bearing N 49°-10'-00" W, a distance of 14.14 feet to a 5/8 inch iron rod set.

N 4°-10'-00" W, a distance of 5.00 feet to a point.

THENCE, N 85°-50'-00" E, a distance of 190.00 feet to a point.

THENCE, S 4°-10'-00" E, a distance of 15.00 feet to the point of beginning.

The basis for bearings is the center-line of South Main Street being S 4°-10'-00" E, and all other bearings are from records of field surveys by Lee Surveying and Mapping Company in 1995.

Description prepared by:

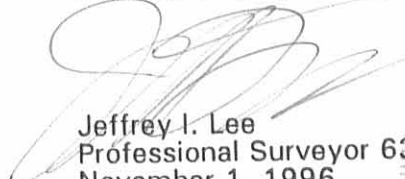
Jeffrey I. Lee
Professional Surveyor 6359
November 1, 1996



ORIGINAL STAMP IN GREEN

INDEXED ON MAP
8971 5D

LOWE'S HOME CENTERS, INC.
18.322 ACRES
O.R. 284, PG. 303

VENTURE PROPERTIES I, LLC
1.037 ACRES
O.R. 259, PG. 825

CONTINENTAL BELL, LTD.
8.403 ACRES
O.R. 276, PG. 579

CONTINENTAL BELL, LTD.
0.799 ACRE
O.R. 276, PG. 574

15 FEET WIDE WATER LINE EASEMENT
THROUGH THE CONTINENTAL BELL, LTD.
0.799 ACRE TRACT
OFFICIAL RECORD 276, PAGES 574
SECTION 32, TOWN 4, RANGE 14
CITY OF BELLEFONTAINE
LIBERTY TOWNSHIP
LOGAN COUNTY, OHIO

INDEXED ON MAP
8971 5P

EXHIBIT



ORIGINAL STAMP IN GREEN

PREPARED BY:

JEFFREY I. LEE
PROFESSIONAL SURVEYOR 6359
NOVEMBER 1, 1996

COPYRIGHT 1996 BY:
LEE SURVEYING & MAPPING CO., INC.
117 North Madriver Street
BELLEFONTAINE, OHIO 43311
(513) 593-7335

D 285 PLASEAS2

L 435-4

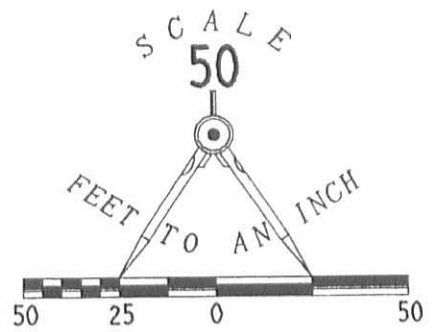

- 5/8" IRON ROD SET
- 5/8" IRON ROD FOUND
- ⊗ RAILROAD SPIKE FOUND
- ⊙ P.K. NAIL SET

CURVE	DELTA	RADIUS	LENGTH	CHORD	CHORD BEARING
C 1	54°04'18"	35.00'	33.03'	31.82'	S 67°07'51"E
C 2	75°19'31"	30.00'	39.44'	36.66'	N 48°10'14"E
C 3	28°45'52"	55.00'	27.61'	27.32'	S 24°53'27"W
C 4	75°19'31"	20.00'	26.29'	24.44'	S 48°10'14"W
C 5	12°46'20"	45.00'	10.03'	10.01'	N 16°53'39"E
C 6	54°04'18"	25.00'	23.59'	22.73'	N 67°07'51"W
C 7	90°00'00"	10.00'	15.71'	14.14'	N 49°10'00"W

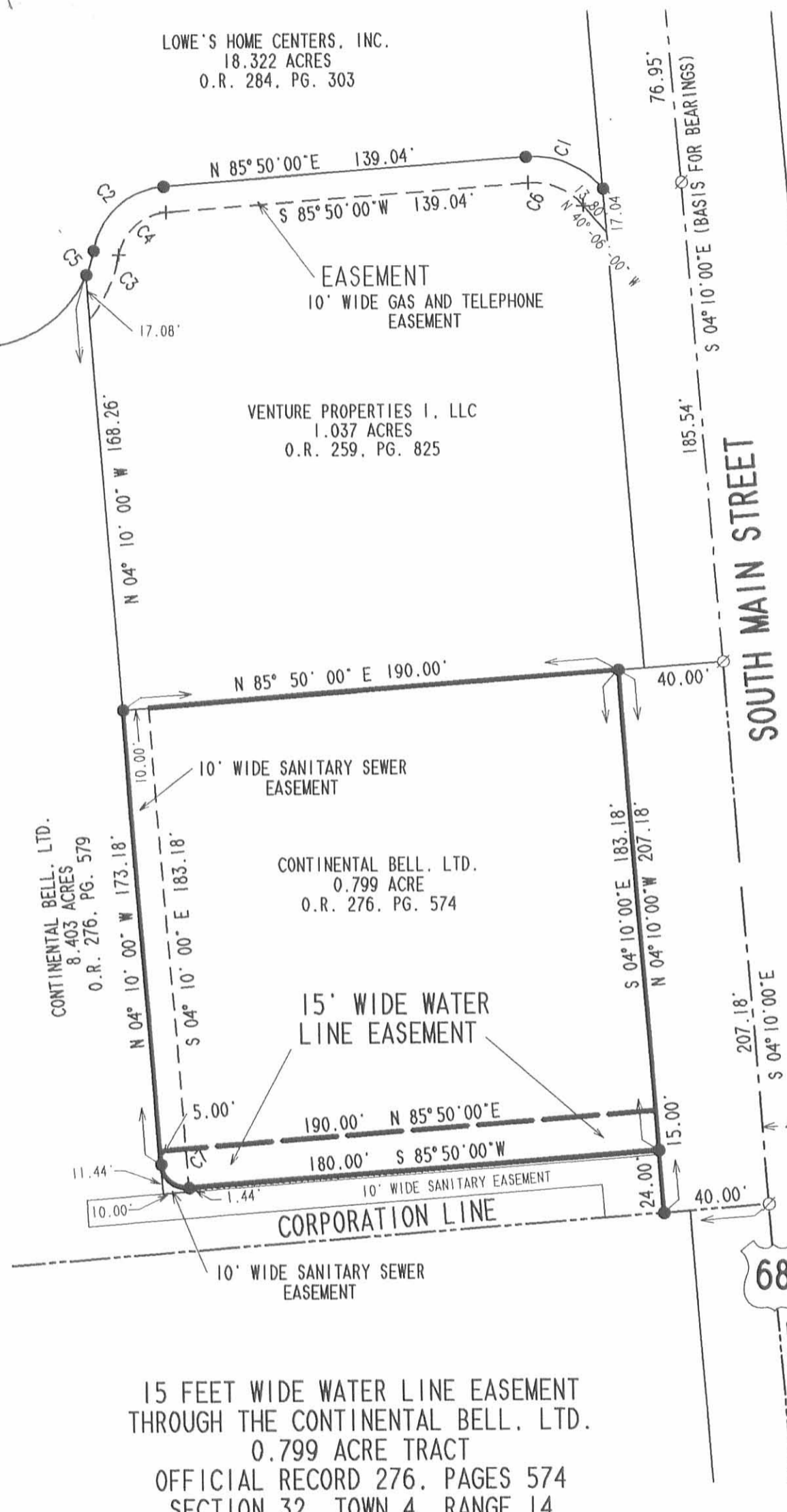

REC'D 6-12-95 SMY OK ✓



Lee Surveying and Mapping Co.



Farm Surveys • Lot Surveys • Topography • Subdivisions • Construction Layout

143 EAST COLUMBUS AVENUE
BELLEFONTAINE, OHIO 43311

(513) 593-7335

JEFFREY I. LEE, P.S.

WILSON ANDERSON 5.613 ACRES

Lying in Section 32, Town 4, Range 14, Liberty Township, Logan County, Ohio.

Being out of the Wilson Anderson original 72.17 acre tract as deeded and described in Volume 390, Page 818 of the Logan County Records of Deeds and being more particularly described as follows:

Beginning at a railroad spike found at the intersection of the north line of Section 32, the center-line of Allen Road and the center-line of South Main Street (U.S. Route 68) in the City of Bellefontaine.

THENCE, with the center-line of South Main Street, S 4°-10'-00" E, a distance of 812.94 feet to a PK nail set at the southeast corner of the Fred L. Allen 0.90 acre tract (O.R. 196, Pg. 516) and the TRUE POINT OF BEGINNING.

THENCE, with the center-line of U.S. Route 68 and a west line of the City of Bellefontaine Corporation, S 4°-10'-00" E, a distance of 76.95 feet to a PK nail set.

THENCE, S 85°-50'-00" W, a distance of 30.00 feet to a 5/8 inch iron rod set.

THENCE, with a non-tangent curve to the left having a central angle of 54°-04'-18", a radius of 35.00 feet, an arc length of 33.03 feet on a chord bearing N 67°-07'-51" W, a chord distance of 31.82 feet to a 5/8 inch iron rod set.

THENCE, S 85°-50'-00" W, a distance of 139.04 feet to a 5/8 inch iron rod set.

THENCE, with a curve to the left having a central angle of 75°-19'-31", a radius of 30.00 feet, an arc length of 39.44 feet on a chord bearing S 48°-10'-14" W, a chord distance of 36.66 feet to a 5/8 inch iron rod set.

THENCE, with a curve to the right having a central angle of 75°-19'-31", a radius of 45.00 feet, an arc length of 59.16 feet on a chord bearing S 48°-10'-14" W, a chord distance of 54.99 feet to a 5/8 inch iron rod set.

THENCE, S 85°-50'-00" W, a distance of 3.00 feet to a 5/8 inch iron rod set.

THENCE, with a curve to the left having a central angle of 90°-00'-00", a radius of 5.00 feet, an arc length of 7.85 feet on a chord bearing S 40°-50'-00" W, a chord distance of 7.07 feet to a 5/8 inch iron rod set.

THENCE, S 4°-10'-00" E, a distance of 13.00 feet to a 5/8 inch iron rod set.

THENCE, S 85°-50'-00" W, a distance of 908.66 feet to a 5/8 inch iron rod set.

THENCE, with the east line of the Conrail properties, N 0°-59'-51" E, a distance of 309.29 feet to a 5/8 inch iron rod set.

THENCE, with the south lines of the Thomas and Marker 11.0 acre and 6.95 acre tracts (Vol. 331, Pg. 332), the Fred L. Allen original 1.039 acre tract (Vol. 400, Pg. 589), and the aforementioned 0.90 acre tract, S 85°-44'-44" E, a distance of 1171.39 feet to the point of beginning.

Containing 5.613 acres of which 0.055 acre is within the highway right-of-way.

The basis for bearings is based upon the center-line of South Main Street (U.S. Route 68) being S 4°-10'-00" E, and all other bearings are from angles and distances measured in a field survey by Lee Surveying and Mapping Company in February 1995.

Description prepared by:

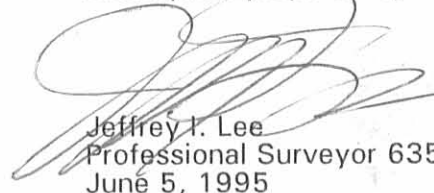
Jeffrey I. Lee
Professional Surveyor 6359
June 5, 1995

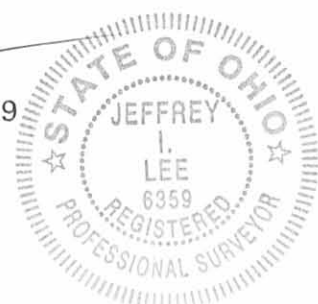

L 435

ORIGINAL STAMP IN GREEN

INDEXED ON MAP
8971 6D-1



Lee Surveying and Mapping Co.



Farm Surveys • Lot Surveys • Topography • Subdivisions • Construction Layout

143 EAST COLUMBUS AVENUE
BELLEFONTAINE, OHIO 43311

(513) 593-7335

JEFFREY I. LEE, P.S.

WILSON ANDERSON 9.392 ACRES

Lying in Section 32, Town 4, Range 14, Liberty Township, Logan County, Ohio.

Being out of the Wilson Anderson original 72.17 acre tract as deeded and described in Volume 390, Page 818 of the Logan County Records of Deeds and being more particularly described as follows:

Beginning at a railroad spike found at the intersection of the north line of Section 32, the center-line of Allen Road and the center-line of South Main Street (U.S. Route 68) in the City of Bellefontaine.

THENCE, with the center-line of South Main Street, S 4°-10'-00" E, a distance of 1075.43 feet to a PK nail set at the TRUE POINT OF BEGINNING.

THENCE, with the center-line of U.S. Route 68 and a west line of the City of Bellefontaine Corporation, S 4°-10'-00" E, a distance of 207.18 feet to a PK nail set.

THENCE with the lines of a 5.165 acre parcel within the aforementioned 72.17 acre tract the following two courses:

S 85°-50'-00" W, a distance of 450.00 feet to a 5/8 inch iron rod found.

S 4°-10'-00" E, a distance of 100.00 feet to a 5/8 inch iron rod set.

THENCE, N 86°-23'-57" W, a distance of 773.39 feet to a 5/8 inch iron rod set.

THENCE, with the east line of the Conrail properties, N 0°-59'-51" E, a distance of 330.00 feet to a 5/8 inch iron rod set.

THENCE, N 85°-50'-00" E, a distance of 908.66 feet to a 5/8 inch iron rod set.

THENCE, N 4°-10'-00" W, a distance of 13.00 feet to a 5/8 inch iron rod set.

THENCE, with a curve to the right having a central angle of 90°-00'-00", a radius of 5.00 feet, an arc length of 7.85 feet on a chord bearing N 40°-50'-00" E, a chord distance of 7.07 feet to a 5/8 inch iron rod set.

THENCE, N 85°-50'-00" E, a distance of 3.00 feet to a 5/8 inch iron rod set.

THENCE, with a curve to the left having a central angle of 62°-33'-11", a radius of 45.00 feet, an arc length of 49.13 feet on a chord bearing N 54°-33'-24" E, a chord distance of 46.73 feet to a 5/8 inch iron rod set.

THENCE, S 4°-10'-00" E, a distance of 168.26 feet to a 5/8 inch iron rod set.

THENCE, N 85°-50'-00" E, a distance of 230.00 feet to the point of beginning.

Containing 9.392 acres of which 0.143 acre is within the highway right-of-way.

The basis for bearings is based upon the center-line of South Main Street (U.S. Route 68) being S 4°-10'-00" E, and all other bearings are from angles and distances measured in a field survey by Lee Surveying and Mapping Company in February 1995.

Description prepared by:

Jeffrey I. Lee
Professional Surveyor 6359
June 5, 1995



L 435

ORIGINAL STAMP IN GREEN

INDEXED ON MAP
8971 6D-2



Lee Surveying and Mapping Co.



Farm Surveys • Lot Surveys • Topography • Subdivisions • Construction Layout

143 EAST COLUMBUS AVENUE
BELLEFONTAINE, OHIO 43311

(513) 593-7335

JEFFREY I. LEE, P.S.

WILSON ANDERSON 1.037 ACRES

Lying in Section 32, Town 4, Range 14, Liberty Township, Logan County, Ohio.

Being out of the Wilson Anderson original 72.17 acre tract as deeded and described in Volume 390, Page 818 of the Logan County Records of Deeds and being more particularly described as follows:

Beginning at a railroad spike found at the intersection of the north line of Section 32, the center-line of Allen Road and the center-line of South Main Street (U.S. Route 68) in the City of Bellefontaine.

THENCE, with the center-line of South Main Street, S 4°-10'-00" E, a distance of 889.89 feet to a PK nail set at the TRUE POINT OF BEGINNING.

THENCE, with the center-line of U.S. Route 68 and a west line of the City of Bellefontaine Corporation, S 4°-10'-00" E, a distance of 185.54 feet to a PK nail set.

THENCE, S 85°-50'-00" W, a distance of 230.00 feet to a 5/8 inch iron rod set.
THENCE, N 4°-10'-00" W, a distance of 168.26 feet to a 5/8 inch iron rod set.

THENCE, with a non-tangent curve to the left having a central angle of 12°-46'-20", a radius of 45.00 feet, an arc length of 10.03 feet on a chord bearing N 16°-53'-39" E, a chord distance of 10.01 feet to a 5/8 inch iron rod set.

THENCE, with a curve to the right having a central angle of 75°-19'-31", a radius of 30.00 feet, an arc length of 39.44 feet on a chord bearing N 48°-10'-14" E, a chord distance of 36.66 feet to a 5/8 inch iron rod set.

THENCE, N 85°-50'-00" E, a distance of 139.04 feet to a 5/8 inch iron rod set.

THENCE, with a curve to the right having a central angle of 54°-04'-18", a radius of 35.00 feet, an arc length of 33.03 feet on a chord bearing S 67°-07'-51" E, a chord distance of 31.82 feet to a 5/8 inch iron rod set.

THENCE, N 85°-50'-00" E, a distance of 30.00 feet to the point of beginning.

Containing 1.037 acres of which 0.128 acre is within the highway right-of-way.

The basis for bearings is based upon the center-line of South Main Street (U.S. Route 68) being S 4°-10'-00" E, and all other bearings are from angles and distances measured in a field survey by Lee Surveying and Mapping Company in February 1995.

Description prepared by:

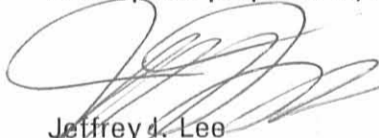
Jeffrey I. Lee
Professional Surveyor 6359
June 5, 1995



L 435

ORIGINAL STAMP IN GREEN

INDEXED ON MAP
8971 60-3



THOMAS AND MARKER CONSTRUCTION COMPANY
 ORIG. 11.0 ACRES
 VOL. 331, PG. 332

THOMAS AND MARKER CONSTRUCTION COMPANY
 6.95 ACRES
 VOL. 331, PG. 332

WILSON ANDERSON
 316.72 AC
 VOL. 390, PG. 818

5.613 ACRES
 OF WHICH 0.055 ACRE IS
 WITHIN THE HIGHWAY
 RIGHT-OF-WAY

CURVE	DELTA ANGLE	RADIUS	ARC	TANGENT	CHORD	CHORD BEARING
C 1	54°04'18"	35.00'	33.03'	17.86'	31.82'	N 67°07'51"W
C 2	75°19'31"	30.00'	39.44'	23.16'	36.66'	S 48°10'14"W
C 3	75°19'31"	45.00'	59.16'	34.73'	54.99'	S 48°10'14"W
C 4	90°00'00"	5.00'	7.85'	5.00'	7.07'	S 40°50'00"W
C 5	12°46'20"	45.00'	10.03'	5.04'	10.01'	N 16°53'39"E
C 6	62°33'11"	45.00'	49.13'	27.34'	46.73'	N 54°33'24"E

1.037 ACRES
 OF WHICH 0.128 ACRE IS
 WITHIN THE HIGHWAY
 RIGHT-OF-WAY

9.392 ACRES
 OF WHICH 0.143 ACRE IS
 WITHIN THE HIGHWAY
 RIGHT-OF-WAY

WILSON ANDERSON
 ORIG. 72.17 AC.
 VOL. 390, PG. 818

NOTES

EASEMENTS SHOWN ARE BASED UPON A LAWYERS TITLE INSURANCE CORPORATION COMMITMENT FOR TITLE INSURANCE BY WILLIAM R. NONGOMERY FOR VENTURE PROPERTIES I, LLC, DATED MAY 18, 1995 AT 8:00 A.M.

ADDITIONAL EASEMENTS MAY AFFECT THIS PROPERTY.

VOLUME 68, PAGE 918, EASEMENT TO DP & L DOES NOT AFFECT THESE PROPERTIES.

LITEL COMMUNICATIONS REQUIRES A LITEL REPRESENTATIVE BE ON SITE WHEN DIGGING WITHIN 10 FEET OF THEIR CABLE.

LITEL COMMUNICATIONS HAS PLANS TO MOVE THEIR BURIED CABLE TO OVERHEAD ON THE SOUTH SIDE OF ALLEN ROAD AND THE WEST SIDE OF SOUTH MAIN ST.

THE UNDERGROUND UTILITIES SHOWN HAVE BEEN LOCATED FROM FIELD SURVEY INFORMATION AND EXISTING DRAWINGS. THE SURVEYOR MAKES NO GUARANTEE THAT THE UNDERGROUND UTILITIES SHOWN COMPRISE ALL SUCH UTILITIES IN THE AREA, EITHER IN SERVICE OR ABANDONED. THE SURVEYOR FURTHER DOES NOT WARRANT THAT THE UNDERGROUND UTILITIES SHOWN ARE IN THE EXACT LOCATION INDICATED. ALTHOUGH, HE DOES STATE THAT THEY ARE LOCATED AS ACCURATELY AS POSSIBLE FROM INFORMATION AVAILABLE. THE SURVEYOR HAS NOT PHYSICALLY LOCATED THE UNDERGROUND UTILITIES.

THE OHIO UTILITIES PROTECTION SERVICE NUMBERS FOR LEE SURVEYING FOR THIS PROJECT ARE 217 013 015 AND 217 013 016. THIS REQUEST WAS RENEWED FOR DP & L ON MARCH 3, 1995, WITH NUMBERS 303 008 028 AND 303 008 029.

TO: VENTURE PROPERTIES I, LLC
 LOWE'S HOME CENTERS, INC.
 WACHOVIA BANK OF NORTH CAROLINA, N.A.
 LAWYERS TITLE INSURANCE CORPORATION

I hereby state that this survey was prepared by me and was actually made upon the ground February 25, 1995, and that it and the information, courses and distances shown hereon are correct to the best of my knowledge and belief; that the title lines and lines of actual possession are the same; that there are presently no buildings on the property except as shown hereon; that there are no easements, encroachments or uses affecting this property appearing from a careful physical inspection of the same, other than those shown and depicted hereon; that all utility services known by me to be required for the operation of the premises either are available to enter the premises through adjoining public streets, or the survey shows the point of entry and location of any utilities which pass through or are located on adjoining private land; and that the parcels shown hereon do not lie within flood hazard areas in accordance with the document entitled "Department of Housing and Urban Development, Federal Insurance Administration - Special Flood Hazard Area Maps 390772 0115 C, 390772 0180 C, and 390772 0185 C with an effective date of May 15, 1985." This survey was made in accordance with the "Minimum Standard Detail Requirements for Land Title Surveys" jointly established and adopted by ALTA and ACSM in 1992, and includes Items 1, 2, 3, 4, 7(a), 8, 9, 10, 11, and 13 of Table A thereof. This survey was prepared pursuant to the Accuracy Standards (as adopted by ALTA and ACSM and in effect on the date of this affidavit) of an Urban Survey.

Jeffrey I. Lee
 Ohio Professional Surveyor 6359
 June 12, 1995



ORIGINAL STAMP IN GREEN

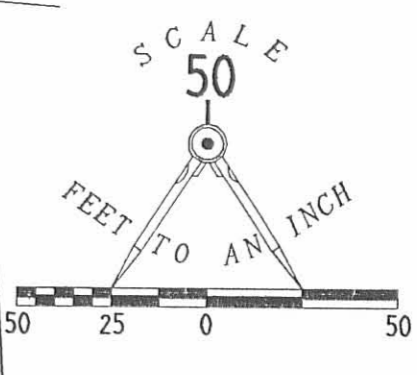
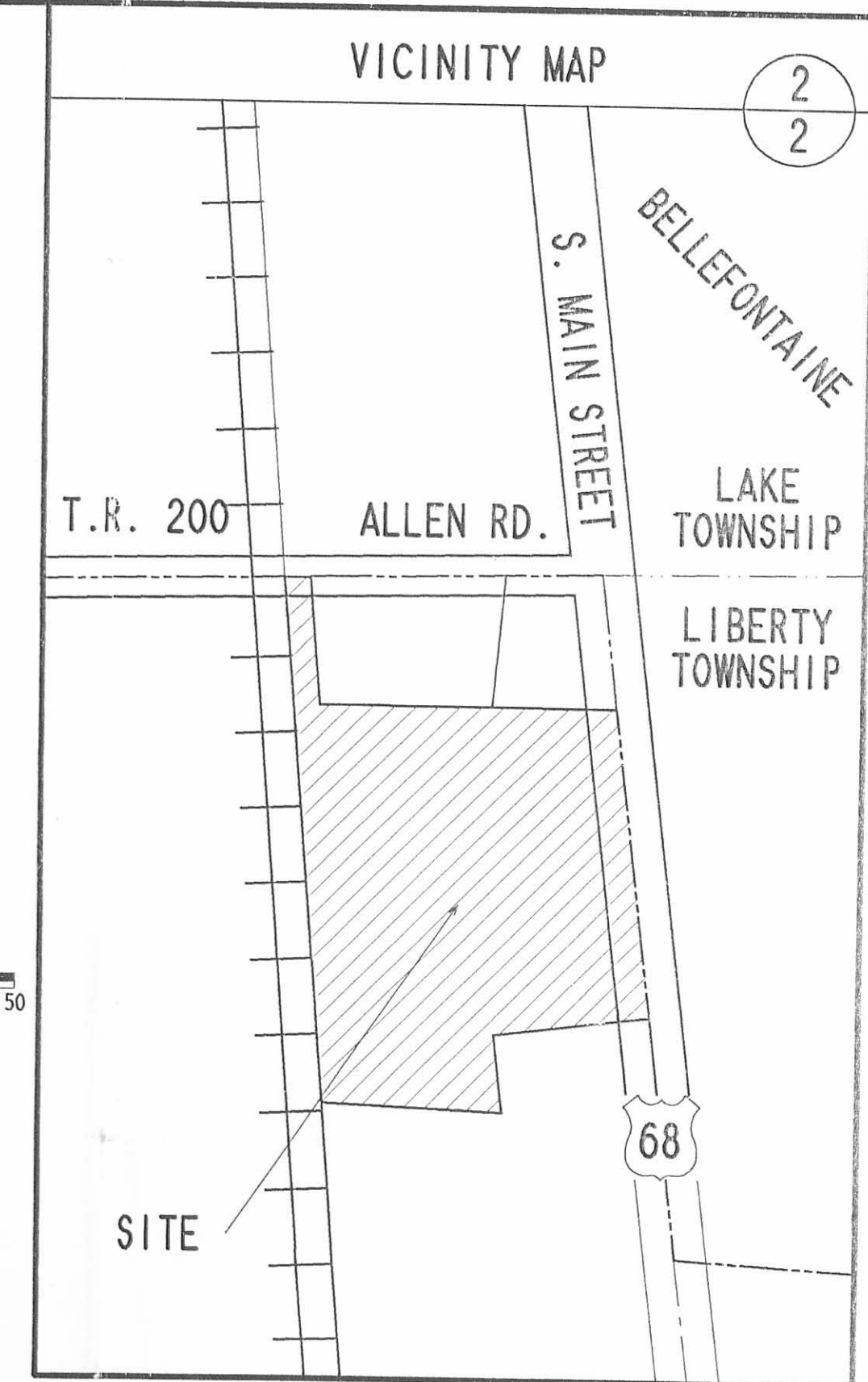

- LEGEND**
- TRANSFORMER PAD
 - LAMP POST
 - POLE
 - GAS METER POST
 - GAS VALVE
 - GAS METER AND REGULATOR
 - TRAFFIC SIGN
 - MAIL BOX
 - SANITARY MANHOLE
 - CATCH BASIN
 - GUY WIRE
 - WOVEN WIRE FENCE
 - WATER VALVE
 - TREE LINE
- ABBREVIATIONS**
- TC TOP OF CURB
 - INV. INVERT
 - CATV CABLE TELEVISION
 - CMC CORRUGATED METAL PIPE
 - RCP REINFORCED CONCRETE PIPE
 - E/P EDGE OF PAVEMENT
- REFERENCES**
- LOGAN COUNTY ENGINEER'S SURVEY RECORDS, DRAWER R, FILE NUMBERS 1638, 777, 2621, 1384, 4314, 3737, AND 2907.
- C.C.C. & ST. LOUIS RY. CO. STATION MAP, STA. 5248+60 TO 5289+71, DATED JUNE 30, 1915.

ALTA / ACSM LAND TITLE SURVEY
 OF THREE TRACTS OUT OF THE
 WILSON ANDERSON
 72.17 ACRE TRACT
 VOLUME 390, PAGE 818
 SECTION 32, TOWN 4, RANGE 14
 LIBERTY TOWNSHIP
 LOGAN COUNTY, OHIO

2 WORKING DAYS
BEFORE YOU DIG
 CALL TOLL FREE 800-362-2764
 OHIO UTILITIES PROTECTION SERVICE.

INDEXED ON MAP
 2/11/95

COPYRIGHT 1995 BY:
 LEE SURVEYING & MAPPING CO.
 143 East Columbus Avenue
 BELLEFONTAINE, OHIO 43311
 (513) 593-7335

D261 LOWEAL72 L 435-1

REC'D 12-21-95 SMY OK ✓



Lee Surveying and Mapping Co.



Farm Surveys • Lot Surveys • Topography • Subdivisions • Construction Layout

143 EAST COLUMBUS AVENUE
BELLEFONTAINE, OHIO 43311

(513) 593-7335

JEFFREY I. LEE, P.S.

WILSON ANDERSON 0.931 ACRE

Lying in Section 32, Town 4, Range 14, Liberty Township, Logan County, Ohio.

Being out of the Wilson Anderson original 72.17 acre tract as deeded and described in Volume 390, Page 818 of the Logan County Records of Deeds and being more particularly described as follows:

Beginning at a railroad spike found at the intersection of the north line of Section 32, the center-line of Allen Road and the center-line of South Main Street (U.S. Route 68) in the City of Bellefontaine.

THENCE, with the center-line of South Main Street, S 4°-10'-00" E, a distance of 1282.61 feet to a PK nail set.

THENCE, with the north line of a 5.165 acre parcel within the Wilson Anderson original 72.17 acre tract (Vol. 390, Pg. 818), S 85°-50'-00" W, a distance of 40.00 feet to a 5/8 inch iron rod set.

THENCE, with the lines of the said 5.165 acre parcel the following two courses:

S 85°-50'-00" W, a distance of 410.00 feet to a 5/8 inch iron rod found.

S 4°-10'-00" E, a distance of 100.00 feet to a 5/8 inch iron rod set at the TRUE POINT OF BEGINNING.

THENCE, through the said original 72.17 acre tract, S 85°-50'-00" W, a distance of 775.75 feet to a 5/8 inch iron rod set.

THENCE, with the east line of the West Central Ohio Port Authority properties (O.R. 268, Pg. 44), N 0°-59'-51" E, a distance of 104.95 feet to a 5/8 inch iron rod set.

THENCE, with the south line of the Venture Properties I, LLC, Ltd. 9.392 acre tract (O.R. 259, Pg. 828), S 86°-23'-57" E, a distance of 773.59 feet to the point of beginning.

Containing 0.931 acre.

The basis for bearings is based upon the center-line of South Main Street (U.S. Route 68) being S 4°-10'-00" E, and all other bearings are from angles and distances measured in a field survey by Lee Surveying and Mapping Company on December 18, 1995.

Description prepared by:

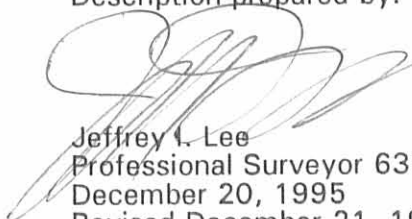
Jeffrey I. Lee
Professional Surveyor 6359
December 20, 1995
Revised December 21, 1995



L 435

ORIGINAL STAMP IN GREEN

INDEXED ON MAP
8971 7D-1

REC'D 12-21-95 SUM OK ✓



Lee Surveying and Mapping Co.



Farm Surveys • Lot Surveys • Topography • Subdivisions • Construction Layout

143 EAST COLUMBUS AVENUE
BELLEFONTAINE, OHIO 43311

(513) 593-7335

JEFFREY I. LEE, P.S.

WILSON ANDERSON 0.931 ACRE

Lying in Section 32, Town 4, Range 14, City of Bellefontaine, Liberty Township, Logan County, Ohio.

Being out of the Wilson Anderson original 72.17 acre tract as deeded and described in Volume 390, Page 818 of the Logan County Records of Deeds and being more particularly described as follows:

Beginning at a railroad spike found at the intersection of the north line of Section 32, the center-line of Allen Road and the center-line of South Main Street (U.S. Route 68) in the City of Bellefontaine.

THENCE, with the center-line of South Main Street, S 4°-10'-00" E, a distance of 1282.61 feet to a PK nail set.

THENCE, with the north line of a 5.165 acre parcel within the Wilson Anderson original 72.17 acre tract (Vol. 390, Pg. 818), S 85°-50'-00" W, a distance of 40.00 feet to a 5/8 inch iron rod set.

THENCE, with the lines of the said 5.165 acre parcel the following two courses:

S 85°-50'-00" W, a distance of 410.00 feet to a 5/8 inch iron rod found.

S 4°-10'-00" E, a distance of 100.00 feet to a 5/8 inch iron rod set at the TRUE POINT OF BEGINNING.

THENCE, through the said original 72.17 acre tract, S 85°-50'-00" W, a distance of 775.75 feet to a 5/8 inch iron rod set.

THENCE, with the east line of the West Central Ohio Port Authority properties (O.R. 268, Pg. 44), N 0°-59'-51" E, a distance of 104.95 feet to a 5/8 inch iron rod set.

THENCE, with the south line of the Venture Properties I, LLC, Ltd. 9.392 acre tract (O.R. 259, Pg. 828), S 86°-23'-57" E, a distance of 773.59 feet to the point of beginning.

Containing 0.931 acre.

The basis for bearings is based upon the center-line of South Main Street (U.S. Route 68) being S 4°-10'-00" E, and all other bearings are from angles and distances measured in a field survey by Lee Surveying and Mapping Company on December 18, 1995.

Description prepared by:

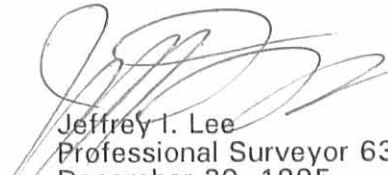

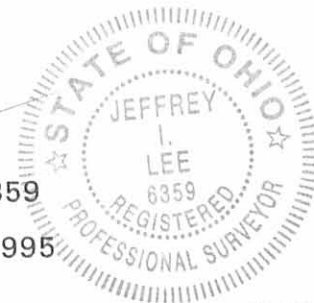
Jeffrey I. Lee
Professional Surveyor 6359
December 20, 1995
Revised December 21, 1995

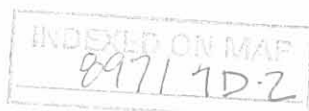

L 435

ORIGINAL STAMP IN GREEN

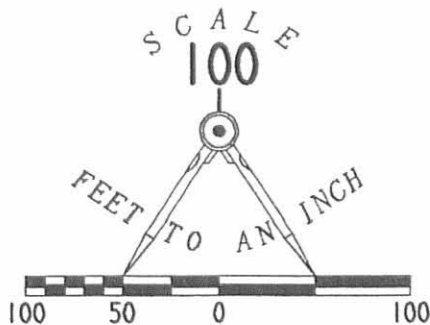



LEGEND

- 5/8" IRON ROD SET W/ PLASTIC I.D. CAP STAMPED "LEE PS6359"
- 5/8" IRON ROD FOUND
- ⊗ RAILROAD SPIKE FOUND
- ⊗ P.K. NAIL SET

REFERENCES

LOGAN COUNTY ENGINEER'S SURVEY RECORDS, DRAWER R, FILE NUMBERS 1638, 777, 2621, 1384, 4314, 3737, AND 2907.

C.C.C. & ST. LOUIS RY. CO. STATION MAP, STA. 5248+60 TO 5289+71, DATED JUNE 30, 1915.

PREVIOUS SURVEY OF BOB EVANS FARMS, INC. 0.959 ACRE TRACT BY LEE SURVEYING AND MAPPING COMPANY, DATED JULY 1992, FILE NO. L-1939-1.

WEST CENTRAL OHIO PORT AUTHORITY
O.R. 268, PG. 44

N 00° 59' 51" E
104.95'

0.931 ACRE

WILSON ANDERSON
ORIG. 72.17 AC.
VOL. 390, PG. 818

2 WORKING DAYS

BEFORE YOU DIG

CALL TOLL FREE **800-362-2764**

OHIO UTILITIES PROTECTION SERVICE.

INDEXED ON MAP
09971 7P

VENTURE PROPERTIES I, LLC. LTD
ORIG. 9.392 ACRES
O.R. 259, PG. 828

POINT OF BEGINNING

S 86° 23' 57" E
773.59'

775.75'
S 85° 50' 00" W

100.00'
S 4° 10' 00" E

WILSON ANDERSON
(5.165 ACRES)
PART OF THE ORIGINAL 72.17 AC.
VOL. 390, PG. 818

410.00'
S 85° 50' 00" W

1282.61'



S 04° 10' 00" E (BASIS FOR BEARINGS)

COUNTY HIGHWAY 200 (ALLEN RD.) SECTION 33 LAKE TOWNSHIP
SECTION 32 LIBERTY TOWNSHIP

REFERENCE POINT OF BEGINNING

SOUTH MAIN STREET

**SURVEY OF 0.931 ACRE OUT OF THE
WILSON ANDERSON ORIGINAL 72.17 ACRE TRACT
VOLUME 390, PAGE 818
SECTION 32, TOWN 4, RANGE 14
CITY OF BELLEFONTAINE
LIBERTY TOWNSHIP
LOGAN COUNTY, OHIO**



ORIGINAL STAMP IN GREEN

SURVEYED BY:

Jeffrey I. Lee
JEFFREY I. LEE
PROFESSIONAL SURVEYOR 6359
DECEMBER 18, 1995
REV. DEC. 21, 1995

COPYRIGHT 1995 BY:
LEE SURVEYING & MAPPING CO.
143 East Columbus Avenue
BELLEFONTAINE, OHIO 43311
(513) 593-7335

D269

PLAS0931

L 435-4

Received 6-6-95 OK gch



Lee Surveying and Mapping Co.



Farm Surveys • Lot Surveys • Topography • Subdivisions • Construction Layout

143 EAST COLUMBUS AVENUE
BELLEFONTAINE, OHIO 43311

(513) 593-7335

JEFFREY I. LEE, P.S.

THOMAS AND MARKER CONSTRUCTION COMPANY 9.765 ACRES

Lying in Section 32, Town 4, Range 14, Liberty Township, Logan County, Ohio.

Being out of the Thomas and Marker Construction Company 11.00 acre and 6.95 acre tracts as deeded and described in Volume 331, Page 332 of the Logan County Records of Deeds and being more particularly described as follows:

Beginning at a railroad spike found at the intersection of the north line of Section 32, the center-line of Allen Road (Township Road 200) and the center-line of South Main Street (U.S. Route 68) in the City of Bellefontaine.

THENCE, with the north line of Section 32, N 85°-51'-18" W, a distance of 1007.84 feet to a railroad spike set at the TRUE POINT OF BEGINNING.

THENCE, S 0°-59'-51" W, a distance of 339.95 feet to a 5/8 inch iron rod set, passing a 5/8 inch iron rod set at 20.03 feet.

THENCE, S 86°-01'-28" E, a distance of 738.13 feet to a 5/8 inch iron rod found at the southwest corner of the Bob Evans Farms, Inc. 0.959 acre tract (O.R. 176, Pg. 37).

THENCE, with the west lines of the Fred L. Allen 2.07 acre (Vol. 323, Pg. 87), 0.151 acre (Vol. 393, Pg. 631), and original 1.039 acre (Vol. 400, Pg. 589) tracts, S 4°-12'-55" E, a distance of 471.58 feet to a wood fence post found, referenced by a 5/8 inch iron rod set S 85°-44'-44" E, a distance of 1.00 feet.

THENCE, with the north line of the Wilson Anderson original 72.17 acre tract (Vol. 390, Pg. 818), N 85°-44'-44" W, a distance of 871.39 feet to a point.

THENCE, with the east line of the Conrail Properties and the west line of the aforesaid 11.0 acre tract, N 0°-59'-51" E, a distance of 803.38 feet to a railroad spike set, passing a 5/8 inch iron rod set at 783.35 feet.

THENCE, with the north line of Section 32, S 85°-51'-18" E, a distance of 90.14 feet to the point of beginning.

Containing 9.765 acres of which 2.791 acres are out of the 11.0 acre tract with 0.041 acre within the highway right-of-way. 6.974 acre is all of the 6.95 acre tract.

The basis for bearings is based upon the center-line of South Main Street (U.S. Route 68) being S 4°-10'-00" E, and all other bearings are from angles and distances measured in a field survey by Lee Surveying and Mapping Company in February 1995.

Description prepared by:



Jeffrey I. Lee
Jeffrey I. Lee
Professional Surveyor 6359
June 5, 1995

L 435

INDEXED ON MAP

0971 BD-1

ORIGINAL STAMP IN GREEN

Received 6-6-95 OK JCH



Lee Surveying and Mapping Co.



Farm Surveys • Lot Surveys • Topography • Subdivisions • Construction Layout

143 EAST COLUMBUS AVENUE
BELLEFONTAINE, OHIO 43311

(513) 593-7335

JEFFREY I. LEE, P.S.

FRED L. ALLEN AND JANET P. ALLEN 3.220 ACRES

Lying in Section 32, Town 4, Range 14, Liberty Township, Logan County, Ohio.

Being all of the Fred L. Allen and Janet P. Allen 2.07 acres as deeded and described in Volume 323, Page 87, the 0.151 acre as deeded and described in Volume 393, Page 631, the remainder of the original 1.039 acre as deeded and described in Volume 400, Page 589, and the 0.90 acre as deeded and described in Official Record 196, Page 516 of the Logan County Records of Deeds and being more particularly described as follows:

Beginning at a railroad spike found at the intersection of the north line of Section 32, the center-line of Allen Road and the center-line of South Main Street (U.S. Route 68) in the City of Bellefontaine.

THENCE, with the center-line of South Main Street, S 4°-10'-00" E, a distance of 339.94 feet to a PK nail found at an angle in the corporation and the TRUE POINT OF BEGINNING.

THENCE, with the center-line of U.S. Route 68 and a west line of the City of Bellefontaine Corporation, S 4°-10'-00" E, a distance of 473.00 feet to a point.

THENCE, with the north line of the Wilson Anderson original 72.17 acre tract (Vol. 390, Pg. 818), N 85°-44'-44" W, a distance of 300.00 feet to a wood fence post found, passing 5/8 inch iron rods set at 40.44 feet and 299.00 feet.

THENCE, with the east line of the Thomas and Marker Construction Company 6.95 acre tract (Vol. 331, Pg. 332), N 4°-12'-55" W, a distance of 471.58 feet to a 5/8 inch iron rod found.

THENCE, with the south line of the Bob Evans Farms, Inc. 0.959 acre tract (O.R. 176, Pg. 37), S 86°-01'-28" E, a distance of 300.19 feet to the point of beginning.

Containing 3.220 acres of which 0.326 acre is within the highway right-of-way.

The basis for bearings is based upon the center-line of South Main Street (U.S. Route 68) being S 4°-10'-00" E, and all other bearings are from angles and distances measured in a field survey by Lee Surveying and Mapping Company in February 1995.

Description prepared by:



Jeffrey I. Lee
Jeffrey I. Lee
Professional Surveyor 6359
June 5, 1995

L 435

ORIGINAL STAMP IN GREEN

INDEXED ON MAP
097180-2

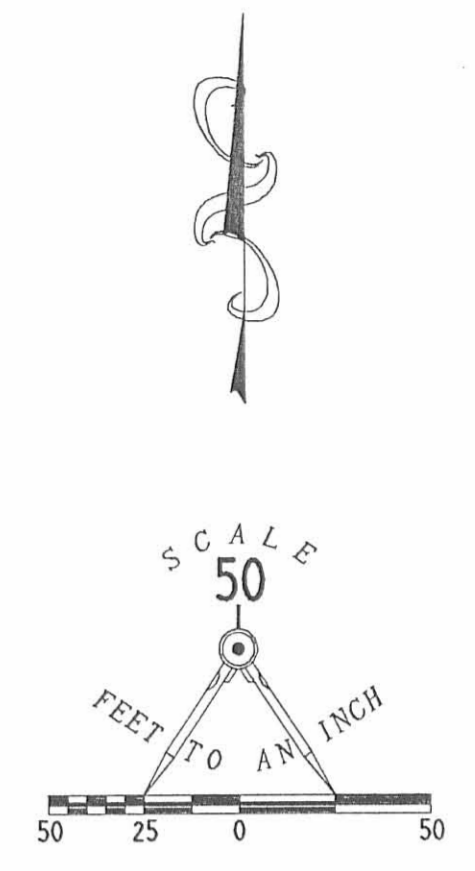

- LEGEND**
- 5/8" IRON ROD SET W/ PLASTIC I.D. CAP STAMPED 'LEE P6359'
 - 5/8" IRON ROD FOUND
 - 1" METAL PIPE FOUND
 - ⊙ RAILROAD SPIKE SET
 - ⊙ RAILROAD SPIKE FOUND
 - ⊙ P.K. NAIL FOUND
 - ⊙ WOOD CORNER POST FOUND

REFERENCES

LOGAN COUNTY ENGINEER'S SURVEY RECORDS, DRAWER R, FILE NUMBERS 1638, 777, 2621, 1384, 4314, 3737, AND 2907.

C.C.C. & ST. LOUIS RY. CO. STATION MAP, STA. 5248+60 TO 5289+71, DATED JUNE 30, 1915.

PREVIOUS SURVEY OF BOB EVANS FARMS, INC. 0.959 ACRE TRACT BY LEE SURVEYING AND MAPPING COMPANY, DATED JULY 1992, FILE NO. L-1939-1.

- NOTES**
1. THIS MAP REPRESENTS A BOUNDARY SURVEY ONLY. NO EASEMENTS ARE SHOWN.
 2. THE CLIENT HAS REQUESTED THAT THE SOUTH MONUMENTS NOT BE SET. THIS EXCEPTION IS PERMITTED UNDER O.A.C. 4733-38-01. ADDITIONAL PERMISSION BY THE LOGAN COUNTY ENGINEER, JIM COX, P.S., P.E. ADDITIONAL MONUMENTS WILL BE SET WHEN THIS PROPERTY IS EXTENDED TO THE SOUTH.

SURVEY OF ALL OF 9.765 ACRES OUT OF THE THOMAS AND MARKER CONSTRUCTION COMPANY 11.0 ACRE TRACT AND 6.95 ACRE TRACT VOLUME 331, PAGE 332 AND A SURVEY OF THE FRED L. ALLEN FOUR TRACTS 3.220 TOTAL ACRES VOLUME 323, PAGE 87; VOLUME 393, PAGE 631; VOLUME 400, PAGE 589; AND OFFICIAL RECORD 196, PAGE 516 SECTION 32, TOWN 4, RANGE 14 LIBERTY TOWNSHIP LOGAN COUNTY, OHIO

SURVEYED BY:

 JEFFREY A. LEE
 PROFESSIONAL SURVEYOR 6359
 FEBRUARY 1995

COPYRIGHT 1995 BY:
 LEE SURVEYING & MAPPING CO.
 143 East Columbus Avenue
 BELLEFONTAINE, OHIO 43311
 (513) 593-7335

ORIGINAL STAMP IN GREEN

2 WORKING DAYS
BEFORE YOU DIG
 CALL TOLL FREE 800-362-2764
 OHIO UTILITIES PROTECTION SERVICE.

INDEXED ON MAP
 8977 DP

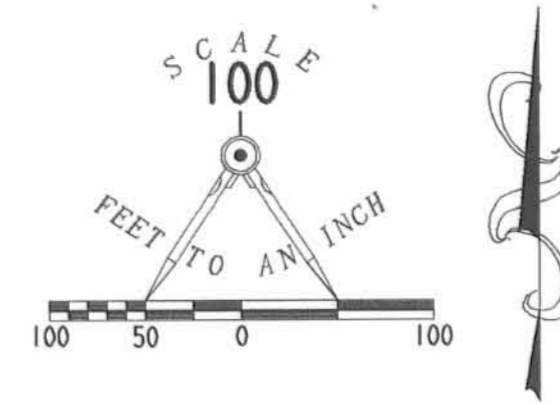
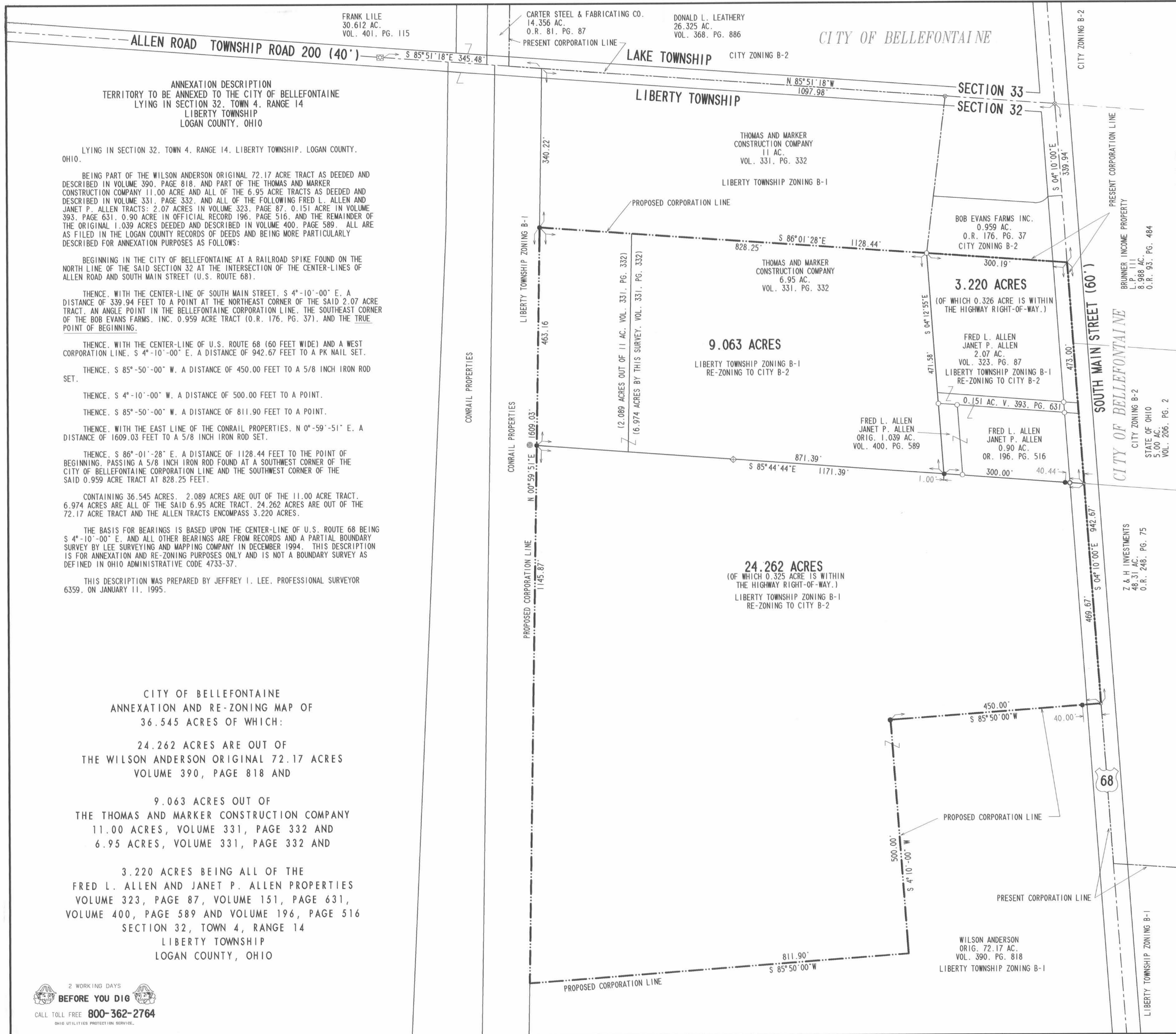

- LEGEND**
- ☐ CONCRETE RESURVEY MONUMENT IN BOX FOUND
 - ⊕ 1-1/2" METAL PIPE FOUND
 - ⊙ 3/4" IRON ROD FOUND
 - ⊙ 5/8" IRON ROD FOUND
 - ⊙ RAILROAD SPIKE FOUND
 - ⊙ RAILROAD SPIKE SET
 - ⊙ 5/8" IRON ROD SET
 - ⊙ PK NAIL SET

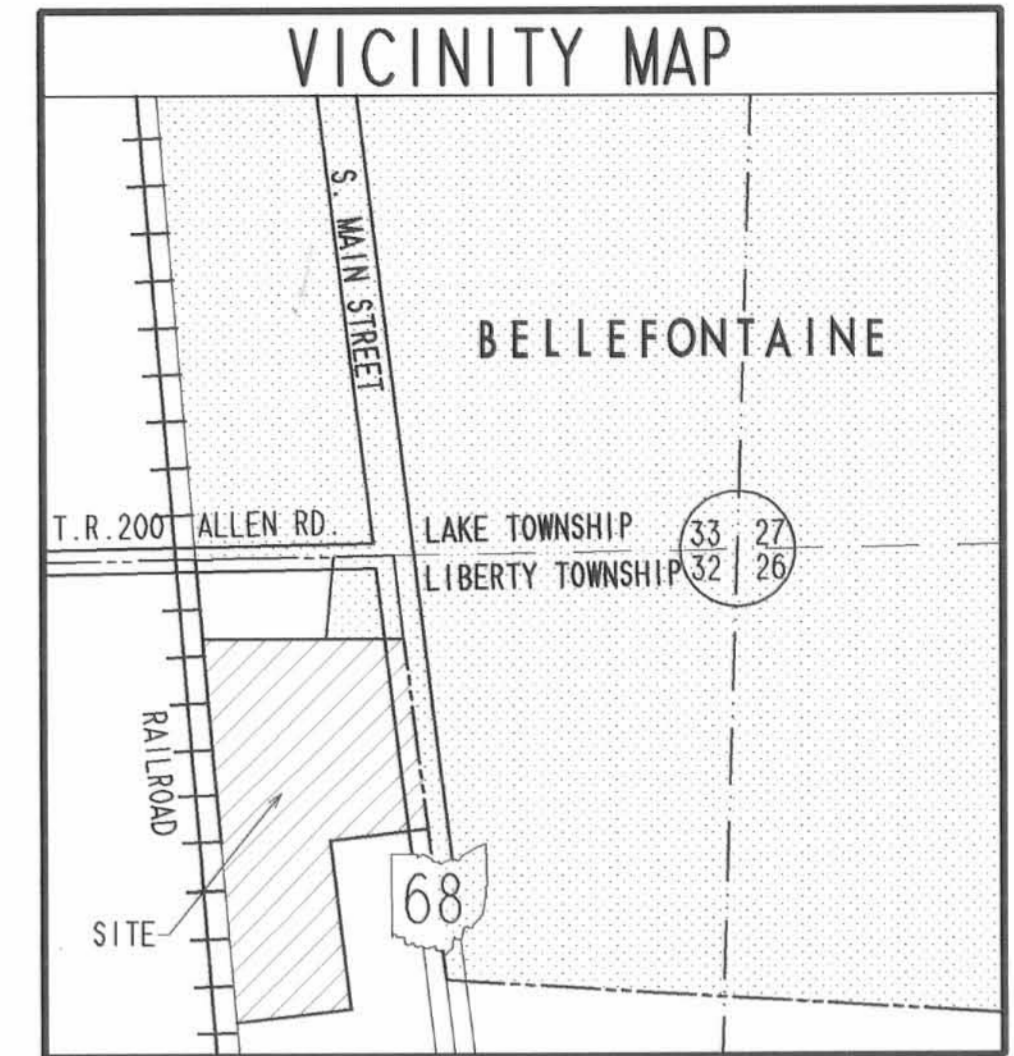

REFERENCES:
 LEE SURVEYING AND MAPPING COMPANY SURVEY NUMBERS 234, 1371, 1996, AND 1939.
 LOGAN COUNTY ENGINEER'S TR 200 FILE.
 LOGAN COUNTY MAP ROOM FILE 'R' NUMBERS 4314 AND 1638.

ANNEXATION DESCRIPTION
 TERRITORY TO BE ANNEXED TO THE CITY OF BELLEFONTAINE
 LYING IN SECTION 32, TOWN 4, RANGE 14
 LIBERTY TOWNSHIP
 LOGAN COUNTY, OHIO

LYING IN SECTION 32, TOWN 4, RANGE 14, LIBERTY TOWNSHIP, LOGAN COUNTY, OHIO.

BEING PART OF THE WILSON ANDERSON ORIGINAL 72.17 ACRE TRACT AS DEEDED AND DESCRIBED IN VOLUME 390, PAGE 818, AND PART OF THE THOMAS AND MARKER CONSTRUCTION COMPANY 11.00 ACRE AND ALL OF THE 6.95 ACRE TRACTS AS DEEDED AND DESCRIBED IN VOLUME 331, PAGE 332, AND ALL OF THE FOLLOWING FRED L. ALLEN AND JANET P. ALLEN TRACTS: 2.07 ACRES IN VOLUME 323, PAGE 87, 0.151 ACRE IN VOLUME 393, PAGE 631, 0.90 ACRE IN OFFICIAL RECORD 196, PAGE 516, AND THE REMAINDER OF THE ORIGINAL 1.039 ACRES DEEDED AND DESCRIBED IN VOLUME 400, PAGE 589. ALL ARE AS FILED IN THE LOGAN COUNTY RECORDS OF DEEDS AND BEING MORE PARTICULARLY DESCRIBED FOR ANNEXATION PURPOSES AS FOLLOWS:

BEGINNING IN THE CITY OF BELLEFONTAINE AT A RAILROAD SPIKE FOUND ON THE NORTH LINE OF THE SAID SECTION 32 AT THE INTERSECTION OF THE CENTER-LINES OF ALLEN ROAD AND SOUTH MAIN STREET (U.S. ROUTE 68).

THENCE, WITH THE CENTER-LINE OF SOUTH MAIN STREET, S 4°-10'-00" E, A DISTANCE OF 339.94 FEET TO A POINT AT THE NORTHEAST CORNER OF THE SAID 2.07 ACRE TRACT, AN ANGLE POINT IN THE BELLEFONTAINE CORPORATION LINE, THE SOUTHEAST CORNER OF THE BOB EVANS FARMS, INC. 0.959 ACRE TRACT (O.R. 176, PG. 37), AND THE TRUE POINT OF BEGINNING.

THENCE, WITH THE CENTER-LINE OF U.S. ROUTE 68 (60 FEET WIDE) AND A WEST CORPORATION LINE, S 4°-10'-00" E, A DISTANCE OF 942.67 FEET TO A PK NAIL SET.

THENCE, S 85°-50'-00" W, A DISTANCE OF 450.00 FEET TO A 5/8 INCH IRON ROD SET.

THENCE, S 4°-10'-00" W, A DISTANCE OF 500.00 FEET TO A POINT.

THENCE, S 85°-50'-00" W, A DISTANCE OF 811.90 FEET TO A POINT.

THENCE, WITH THE EAST LINE OF THE CONRAIL PROPERTIES, N 0°-59'-51" E, A DISTANCE OF 1609.03 FEET TO A 5/8 INCH IRON ROD SET.

THENCE, S 86°-01'-28" E, A DISTANCE OF 1128.44 FEET TO THE POINT OF BEGINNING, PASSING A 5/8 INCH IRON ROD FOUND AT A SOUTHWEST CORNER OF THE CITY OF BELLEFONTAINE CORPORATION LINE AND THE SOUTHWEST CORNER OF THE SAID 0.959 ACRE TRACT AT 828.25 FEET.

CONTAINING 36.545 ACRES, 2.089 ACRES ARE OUT OF THE 11.00 ACRE TRACT, 6.974 ACRES ARE ALL OF THE SAID 6.95 ACRE TRACT, 24.262 ACRES ARE OUT OF THE 72.17 ACRE TRACT AND THE ALLEN TRACTS ENCOMPASS 3.220 ACRES.

THE BASIS FOR BEARINGS IS BASED UPON THE CENTER-LINE OF U.S. ROUTE 68 BEING S 4°-10'-00" E, AND ALL OTHER BEARINGS ARE FROM RECORDS AND A PARTIAL BOUNDARY SURVEY BY LEE SURVEYING AND MAPPING COMPANY IN DECEMBER 1994. THIS DESCRIPTION IS FOR ANNEXATION AND RE-ZONING PURPOSES ONLY AND IS NOT A BOUNDARY SURVEY AS DEFINED IN OHIO ADMINISTRATIVE CODE 4733-37.

THIS DESCRIPTION WAS PREPARED BY JEFFREY I. LEE, PROFESSIONAL SURVEYOR 6359, ON JANUARY 11, 1995.

CITY OF BELLEFONTAINE
 ANNEXATION AND RE-ZONING MAP OF
 36.545 ACRES OF WHICH:

24.262 ACRES ARE OUT OF
 THE WILSON ANDERSON ORIGINAL 72.17 ACRES
 VOLUME 390, PAGE 818 AND

9.063 ACRES OUT OF
 THE THOMAS AND MARKER CONSTRUCTION COMPANY
 11.00 ACRES, VOLUME 331, PAGE 332 AND
 6.95 ACRES, VOLUME 331, PAGE 332 AND

3.220 ACRES BEING ALL OF THE
 FRED L. ALLEN AND JANET P. ALLEN PROPERTIES
 VOLUME 323, PAGE 87, VOLUME 151, PAGE 631,
 VOLUME 400, PAGE 589 AND VOLUME 196, PAGE 516
 SECTION 32, TOWN 4, RANGE 14
 LIBERTY TOWNSHIP
 LOGAN COUNTY, OHIO

LOGAN COUNTY COMMISSIONERS	<i>George W. Clayton</i>	4-27-95
	<i>Johnna Jeffery</i>	4-27-95
	<i>Russell Fongth</i>	4-27-95
LOGAN COUNTY ENGINEER	<i>James K. Co</i>	12-12-95
CHAIRMAN, TOWNSHIP TRUSTEES	<i>David L. Turner</i>	12-12-95
L.U.C. PLANNING DIRECTOR	<i>Quenna Scott</i>	10-12-95
MAYOR OF BELLEFONTAINE	<i>Richard J. Vicario</i>	12-11-95
PRESIDENT, CITY COUNCIL	<i>William R. Patterson</i>	10-24-95
CLERK, CITY COUNCIL	<i>Adelthe Pedmore</i>	10-24-95
PLAT PRE-APPROVED	<i>Suzanne M. Upstey</i>	2-15-95
PLAT CHECKED	<i>Jon C. Rhine</i>	12-27-95
CITY ORDINANCE NUMBER	95-62,	9-12-95
TRANSFERRED THIS	27 th DAY OF	December, 19 95
LOGAN COUNTY AUDITOR	<i>Michael E. Jordan</i>	
RECEIVED FOR RECORD AT	12:41 O'CLOCK P. M.	9509009
THIS	27 th DAY OF	December, 19 95
LOGAN COUNTY RECORDER	<i>Carolyn Collins</i>	
RECORDED IN PLAT CABINET	B	SLIDE 4B

PREPARED BY:
Jeffrey I. Lee
 JEFFREY I. LEE
 PROFESSIONAL SURVEYOR 6359
 JANUARY 2, 1994
LEE SURVEYING & MAPPING CO.
 143 East Columbus Avenue
 BELLEFONTAINE, OHIO 43311
 (513) 593-7335
 D252 VENTURE 435-1

2 WORKING DAYS
BEFORE YOU DIG
 CALL TOLL FREE 800-362-2764
 OHIO UTILITIES PROTECTION SERVICE

REC'D 3-21-94 Smg OK ✓



Lee Surveying and Mapping Co., Inc.



Farm Surveys • Lot Surveys • Topography • Subdivisions • Construction Layout

143 EAST COLUMBUS AVENUE
BELLEFONTAINE, OHIO 43311

(513) 593-7335
FAX (513) 593-7444

COMBINED PARCELS DESCRIPTION VENTURE PROPERTIES I, LLC, LTD. 18.322 ACRES

Lying in Section 32, Town 4, Range 14, City of Bellefontaine and Liberty Township, Logan County, Ohio.

Being all of the Venture Properties I, LLC, Ltd. 5.613 acre tract as deeded and described in Official Record 259, Page 822, all of the 9.765 acre tract as deeded and described in Official Record 259, Page 816, and part of the 3.220 acre tract as deeded and described in Official Record 259, Page 819, with all of the referenced deeds being from the Logan County Records of Deeds and being more particularly described as follows:

Beginning at a railroad spike found at the intersection of the north line of Section 32, the center-line of Allen Road (Township Road 200) and the center-line of South Main Street (U.S. Route 68) in the City of Bellefontaine.

THENCE, with the north line of Section 32, N 85°-51'-18" W, a distance of 1007.84 feet to a railroad spike set at the TRUE POINT OF BEGINNING.

THENCE, through the Thomas and Marker Construction Company original 11.0 acre tract (Vol. 331, Pg. 332) and with a line of the aforesaid 9.765 acre tract, S 0°-59'-51" W, a distance of 339.95 feet to a 5/8 inch iron rod set, passing a 5/8 inch iron rod set at 20.03 feet.

THENCE, with the south line of the said original 11.0 acre tract, S 86°-01'-28" E, a distance of 738.13 feet to a 5/8 inch iron rod found at the southwest corner of the Bob Evans Farms, Inc. 0.959 acre tract (O.R. 176, Pg. 37).

THENCE, with the west line of the aforesaid 3.220 acre tract, S 4°-12'-55" E, a distance of 40.41 feet to a 5/8 inch iron rod set.

THENCE, S 86°-01'-28" E, a distance of 300.16 feet to a PK nail set, passing a 5/8 inch iron rod set at 269.85 feet.

THENCE, with the center-line of U.S. Route 68 and a west line of the City of Bellefontaine Corporation, S 4°-10'-00" E, a distance of 509.54 feet to a PK nail set at the southeast corner of the aforementioned 5.613 acre tract.

THENCE, with the northerly lines of the Venture Properties I, LLC, Ltd. 1.037 acre (O.R. 259, Pg. 825) and the 9.392 acre (O.R. 259, Pg. 828) tracts the following nine courses:

S 85°-50'-00" W, a distance of 30.00 feet to a 5/8 inch iron rod set.

With a non-tangent curve to the left having a central angle of 54°-04'-18", a radius of 35.00 feet, an arc length of 33.03 feet on a chord bearing N 67°-07'-51" W, a chord distance of 31.82 feet to a 5/8 inch iron rod set.

S 85°-50'-00" W, a distance of 139.04 feet to a 5/8 inch iron rod set.

With a curve to the left having a central angle of 75°-19'-31", a radius of 30.00 feet, an arc length of 39.44 feet on a chord bearing S 48°-10'-14" W, a chord distance of 36.66 feet to a 5/8 inch iron rod set.

With a curve to the right having a central angle of 75°-19'-31", a radius of 45.00 feet, an arc length of 59.16 feet on a chord bearing S 48°-10'-14" W, a chord distance of 54.99 feet to a 5/8 inch iron rod set.

INDEXED ON MAP

0971 9D-1



Lee Surveying and Mapping Co., Inc.

Farm Surveys • Lot Surveys • Topography • Subdivisions • Construction Layout

143 EAST COLUMBUS AVENUE
BELLEFONTAINE, OHIO 43311

(513) 593-7335
FAX (513) 593-7444

S 85°-50'-00" W, a distance of 3.00 feet to a 5/8 inch iron rod set.

With a curve to the left having a central angle of 90°-00'-00", a radius of 5.00 feet, an arc length of 7.85 feet on a chord bearing S 40°-50'-00" W, a chord distance of 7.07 feet to a 5/8 inch iron rod set.

S 4°-10'-00" E, a distance of 13.00 feet to a 5/8 inch iron rod set.

S 85°-50'-00" W, a distance of 908.66 feet to a 5/8 inch iron rod set.

THENCE, with the east line of the West Central Ohio Port Authority properties (O.R. 268, Pg. 44), N 0°-59'-51" E, a distance of 1112.67 feet to a railroad spike set, passing a 5/8 inch iron rod set at 1092.64 feet.

THENCE, with the north line of Section 32 and the center-line of County Highway 200, S 85°-51'-18" E, a distance of 90.14 feet to the point of beginning.

Containing 18.322 acres which is all of the 5.613 acre and 9.765 acre tracts, and 2.944 acres out of the 3.220 acre tract. 0.435 acre is within the highway rights-of-way. 9.063 acres of the 9.765 acre tract are in the City of Bellefontaine.

The basis for bearings is based upon the center-line of South Main Street (U.S. Route 68) being S 4°-10'-00" E, and all other bearings are from angles and distances measured in field surveys by Lee Surveying and Mapping Company in February, June, and December, 1995.

Description prepared by:

Jeffrey I. Lee
Professional Surveyor 6359
December 5, 1995
Revised March 21, 1996



L 435

ORIGINAL STAMP IN GREEN

INDEXED ON MAP
8971 9D 2

REC'D 3-21-96 SMLY OK ✓



Lee Surveying and Mapping Co., Inc.



Farm Surveys • Lot Surveys • Topography • Subdivisions • Construction Layout

143 EAST COLUMBUS AVENUE
BELLEFONTAINE, OHIO 43311

(513) 593-7335
FAX (513) 593-7444

VENTURE PROPERTIES I, LLC, LTD. 0.276 ACRE

Lying in Section 32, Town 4, Range 14, City of Bellefontaine, Liberty Township, Logan County, Ohio.

Being out of the Venture Properties I, LLC, Ltd. 3.220 acre tract as deeded and described in Official Record 259, Page 819 of the Logan County Records of Deeds and being more particularly described as follows:

Beginning at a railroad spike found at the intersection of the north line of Section 32, the center-line of Allen Road and the center-line of South Main Street (U.S. Route 68) in the City of Bellefontaine.

THENCE, with the center-line of South Main Street, S 4°-10'-00" E, a distance of 339.94 feet to a PK nail set at an angle in the corporation line and the TRUE POINT OF BEGINNING.

THENCE, with the center-line of U.S. Route 68 and a west corporation line of the City of Bellefontaine, S 4°-10'-00" E, a distance of 40.41 feet to a PK nail set.

THENCE, through the aforesaid 3.220 acre tract, N 86°-01'-28" W, a distance of 300.16 feet to a 5/8 inch iron rod set, passing a 5/8 inch iron rod set at 30.31 feet.

THENCE, with the east line of the Venture Properties I, LLC, Ltd 9.765 acre tract (O.R. 259, Pg. 816), N 4°-12'-55" W, a distance of 40.41 feet to a 5/8 inch iron rod found at the southwest corner of the Bob Evans Farms, Inc. 0.959 acre tract (O.R. 176, Pg. 37).

THENCE, with the south line of the said 0.959 acre tract, S 86°-01'-28" E, a distance of 300.19 feet to the point of beginning.

Containing 0.276 acre of which 0.028 acre is within the highway right-of-way.

The basis for bearings is based upon the center-line of South Main Street (U.S. Route 68) being S 4°-10'-00" E, and all other bearings are from angles and distances measured in a field survey by Lee Surveying and Mapping Company on December 4, 1995.

Description prepared by:

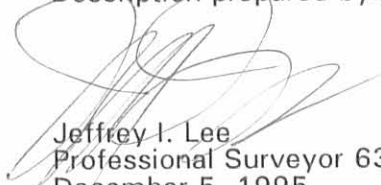

Jeffrey I. Lee
Professional Surveyor 6359
December 5, 1995
Revised March 21, 1996



L 435

ORIGINAL STAMP IN GREEN

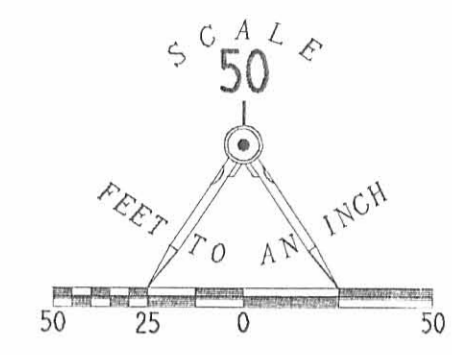
INDEXED ON MAP
8971 AD-3



- LEGEND**
- 5/8" IRON ROD SET W/ PLASTIC I.D. CAP STAMPED "LEE P56359"
 - 5/8" IRON ROD FOUND
 - 1" METAL PIPE FOUND
 - ⊕ RAILROAD SPIKE SET
 - ⊕ RAILROAD SPIKE FOUND
 - ⊕ P.K. NAIL SET
 - ⊕ WOOD CORNER POST FOUND

REFERENCES

LOGAN COUNTY ENGINEER'S SURVEY RECORDS, DRAWER R, FILE NUMBERS 1638, 777, 2621, 1384, 4314, 3737, AND 2907.

C.C.C. & ST. LOUIS RY. CO. STATION MAP, STA. 5248+60 TO 5289+71, DATED JUNE 30, 1915.

PREVIOUS SURVEY OF BOB EVANS FARMS, INC. 0.959 ACRE TRACT BY LEE SURVEYING AND MAPPING COMPANY, DATED JULY 1992, FILE NO. L-1939-1.

CURVE	DELTA ANGLE	RADIUS	ARC	TANGENT	CHORD	CHORD BEARING
C 1	54°04'18"	35.00'	33.03'	17.86'	31.82'	N 67°07'51"W
C 2	75°19'31"	30.00'	39.44'	23.16'	36.66'	S 48°10'14"W
C 3	75°19'31"	45.00'	59.16'	34.73'	54.99'	S 48°10'14"W
C 4	90°00'00"	5.00'	7.85'	5.00'	7.07'	S 40°50'00"W
C 5	12°46'20"	45.00'	10.03'	5.04'	10.01'	N 16°53'39"E
C 6	62°33'11"	45.00'	49.13'	27.34'	46.73'	N 54°33'24"E

RETRACEMENT SURVEY OF THE VENTURE PROPERTY I, LLC LTD
9.765 ACRE TRACT, OFFICIAL RECORD 259, PAGE 816.
5.613 ACRE TRACT, OFFICIAL RECORD 259, PAGE 822.
3.220 ACRE TRACT, OFFICIAL RECORD 259, PAGE 819.
AND 0.276 ACRE OUT OF THE 3.220 ACRE TRACT
SECTION 32, TOWN 4, RANGE 14
LIBERTY TOWNSHIP
LOGAN COUNTY, OHIO



SURVEYED BY:
Jeffrey I. Lee
JEFFREY I. LEE
PROFESSIONAL SURVEYOR 6359
DECEMBER 4, 1995

COPYRIGHT 1995 BY:
LEE SURVEYING & MAPPING CO.
143 East Columbus Avenue
BELLEFONTAINE, OHIO 43311
(513) 593-7335

ORIGINAL STAMP IN GREEN

REC'D 12-20-95 SURV O.K. ✓



Lee Surveying and Mapping Co.



Farm Surveys • Lot Surveys • Topography • Subdivisions • Construction Layout

143 EAST COLUMBUS AVENUE
BELLEFONTAINE, OHIO 43311

(513) 593-7335

JEFFREY I. LEE, P.S.

VENTURE PROPERTIES I, LLC, LTD. 0.799 ACRE

Lying in Section 32, Town 4, Range 14, City of Bellefontaine, Liberty Township, Logan County, Ohio.

Being out of the Venture Properties I, LLC, Ltd. 9.392 acre tract as deeded and described in Official Record 259, Page 828 of the Logan County Records of Deeds and being more particularly described as follows:

Beginning at a railroad spike found at the intersection of the north line of Section 32, the center-line of Allen Road and the center-line of South Main Street (U.S. Route 68) in the City of Bellefontaine.

THENCE, with the center-line of South Main Street, S 4°-10'-00" E, a distance of 1075.43 feet to a PK nail set.

THENCE, with the south line of the Venture Properties I, LLC, Ltd. 1.037 acre tract (O.R. 259, Pg. 825), S 85°-50'-00" W, a distance of 40.00 feet to a 5/8 inch iron rod set at the TRUE POINT OF BEGINNING.

THENCE, parallel with the center-line of U.S. Route 68 and 40.00 feet distant, S 4°-10'-00" E, a distance of 183.18 feet to a 5/8 inch iron rod set.

THENCE, S 85°-50'-00" W, a distance of 180.00 feet to a 5/8 inch iron rod set.

THENCE, with a curve to the right having a central angle of 90°-00'-00", a radius of 10.00 feet, an arc length of 15.71 feet on a chord bearing N 49°-10'-00" W, a chord distance of 14.14 feet to a 5/8 inch iron rod set.

THENCE, N 4°-10'-00" W, a distance of 173.18 feet to a 5/8 inch iron rod set.

THENCE, with the south line of the said 1.037 acre tract, N 85°-50'-00" E, a distance of 190.00 feet to the point of beginning.

Containing 0.799 acre.

The basis for bearings is based upon the center-line of South Main Street (U.S. Route 68) being S 4°-10'-00" E, and all other bearings are from angles and distances measured in a field survey by Lee Surveying and Mapping Company in February and November, 1995.

Description prepared by:

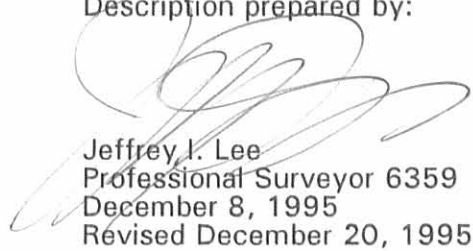
Jeffrey I. Lee
Professional Surveyor 6359
December 8, 1995
Revised December 20, 1995



L 435

INDEXED ON MAP
897/100-1

ORIGINAL STAMP IN GREEN

REC'D 12-20-95 SMJ AK ✓



Lee Surveying and Mapping Co.



Farm Surveys • Lot Surveys • Topography • Subdivisions • Construction Layout

143 EAST COLUMBUS AVENUE
BELLEFONTAINE, OHIO 43311

(513) 593-7335

JEFFREY I. LEE, P.S.

VENTURE PROPERTIES I, LLC, LTD. 0.190 ACRE HIGHWAY RIGHT-OF-WAY

Lying in Section 32, Town 4, Range 14, City of Bellefontaine, Liberty Township, Logan County, Ohio.

Being out of the Venture Properties I, LLC, Ltd. 9.392 acres as deeded and described in Official Record 259, Page 828 of the Logan County Records of Deeds and being more particularly described as follows:

Beginning at a railroad spike found at the intersection of the north line of Section 32, the center-line of Allen Road and the center-line of South Main Street (U.S. Route 68) in the City of Bellefontaine.

THENCE, with the center-line of South Main Street, S 4°-10'-00" E, a distance of 1075.43 feet to a PK nail set at the TRUE POINT OF BEGINNING.

THENCE, with the center-line of U.S. Route 68 and a west corporation line of the City of Bellefontaine, S 4°-10'-00" E, a distance of 207.18 feet to a PK nail set.

THENCE, with the north line of the Wilson Anderson 5.165 acre tract (part of the original 72.17 acre tract in Vol. 390, Pg. 818), S 85°-50'-00" W, a distance of 40.00 feet to a 5/8 inch iron rod set.

THENCE, N 4°-10'-00" W, a distance of 207.18 feet to a 5/8 inch iron rod set.

THENCE, with the south line of the Venture Properties I, LLC, Ltd. 1.037 acre tract (O.R. 259, Pg. 825), N 85°-50'-00" E, a distance of 40.00 feet to the point of beginning.

Containing 0.190 acre.

The basis for bearings is the center-line of South Main Street is S 4°-10'-00" E, and all other bearings are from angles and distances measured in a field survey by Lee Surveying and Mapping Company on November 28, 1995.

Description prepared by:

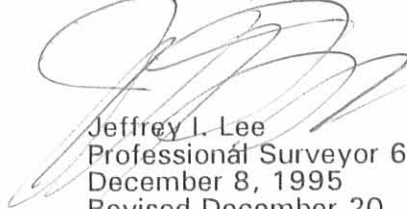
Jeffrey I. Lee
Professional Surveyor 6359
December 8, 1995
Revised December 20, 1995



ORIGINAL STAMP IN GREEN

INDEXED ON MAP
8971-10D-2

REC'D - 12-20-95 GUY JIC ✓



Lee Surveying and Mapping Co.



Farm Surveys • Lot Surveys • Topography • Subdivisions • Construction Layout

143 EAST COLUMBUS AVENUE
BELLEFONTAINE, OHIO 43311

(513) 593-7335

JEFFREY I. LEE, P.S.

VENTURE PROPERTIES I, LLC, LTD. 8.403 ACRES

Lying in Section 32, Town 4, Range 14, City of Bellefontaine, Liberty Township, Logan County, Ohio.

Being out of the Venture Properties I, LLC, Ltd. 9.392 acre tract as deeded and described in Official Record 259, Page 828 of the Logan County Records of Deeds and being more particularly described as follows:

Beginning at a railroad spike found at the intersection of the north line of Section 32, the center-line of Allen Road and the center-line of South Main Street (U.S. Route 68) in the City of Bellefontaine.

THENCE, with the center-line of South Main Street, S 4°-10'-00" E, a distance of 1282.61 feet to a PK nail set.

THENCE, with the north line of a 5.165 acre parcel within the Wilson Anderson original 72.17 acre tract (Vol. 390, Pg. 818), S 85°-50'-00" W, a distance of 40.00 feet to a 5/8 inch iron rod set at the TRUE POINT OF BEGINNING.

THENCE, with the lines of the said 5.165 acre parcel the following two courses:

S 85°-50'-00" W, a distance of 410.00 feet to a 5/8 inch iron rod found.

S 4°-10'-00" E, a distance of 100.00 feet to a 5/8 inch iron rod set.

THENCE, through the said original 72.17 acre tract and with the south line of the said 9.392 acre tract, N 86°-23'-57" W, a distance of 773.39 feet to a 5/8 inch iron rod set.

THENCE, with the east line of the West Central Ohio Port Authority properties (O.R. 268, Pg. 44), N 0°-59'-51" E, a distance of 330.00 feet to a 5/8 inch iron rod set.

THENCE, with the south lines of the Venture Properties I, LLC, Ltd. 5.613 acre tract (O.R. 259, Pg. 822) the following five courses:

N 85°-50'-00" E, a distance of 908.66 feet to a 5/8 inch iron rod set.

N 4°-10'-00" W, a distance of 13.00 feet to a 5/8 inch iron rod set.

With a curve to the right having a central angle of 90°-00'-00", a radius of 5.00 feet, an arc length of 7.85 feet on a chord bearing N 40°-50'-00" E, a chord distance of 7.07 feet to a 5/8 inch iron rod set.

N 85°-50'-00" E, a distance of 3.00 feet to a 5/8 inch iron rod set.

With a curve to the left having a central angle of 62°-33'-11", a radius of 45.00 feet, an arc length of 49.13 feet on a chord bearing N 54°-33'-24" E, a chord distance of 46.73 feet to a 5/8 inch iron rod set.

THENCE, with the west line of the Venture Properties I, LLC, Ltd., 1.037 acre tract (O.R. 259, Pg. 825) and the west line of an 0.799 acre tract created simultaneously with this described parcel and being part of the aforesaid 9.392 acre tract, S 4°-10'-00" E, a distance of 341.44 feet to a 5/8 inch iron rod set.

THENCE, with a curve to the left having a central angle of 90°-00'-00", a radius of 10.00 feet, an arc length of 15.71 feet on a chord bearing S 49°-10'-00" E, a chord distance of 14.14 feet to a 5/8 inch iron rod set.

THENCE, N 85°-50'-00" E, a distance of 180.00 feet to a 5/8 inch iron rod set.

THENCE, S 4°-10'-00" E, a distance of 24.00 feet to the point of beginning.

Containing 8.403 acres.

The basis for bearings is based upon the center-line of South Main Street (U.S. Route 68) being S 4°-10'-00" E, and all other bearings are from angles and distances measured in a field survey by Lee Surveying and Mapping Company in February and November, 1995.

Description prepared by:

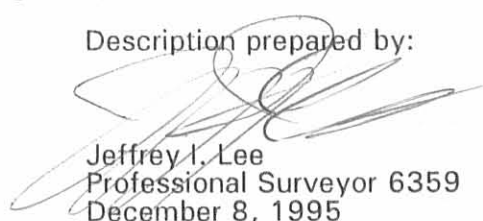
Jeffrey I. Lee
Professional Surveyor 6359
December 8, 1995
Revised December 20, 1995

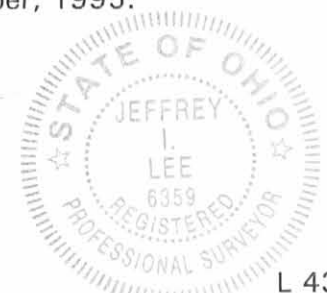

INDEXED ON MAP
8971 10D-3

L 435
ORIGINAL STAMP IN GREEN

VENTURE PROPERTIES I. LLC. LTD
9.765 ACRES
O.R. 259, 816

VENTURE PROPERTIES I. LLC. LTD
5.613 ACRES
O.R. 259, 822

VENTURE PROPERTIES I. LLC. LTD
3.220 ACRES
O.R. 259, 819

VENTURE PROPERTIES I. LLC LTD
1.037 ACRES
O.R. 259, PG. 825

8.403 ACRES
VENTURE PROPERTIES I. LLC. LTD
ORIG. 9.392 ACRES
O.R. 259, PG. 828

0.931 ACRE
WILSON ANDERSON
ORIG. 72.17 AC.
VOL. 390, PG. 818

WILSON ANDERSON
ORIG. 72.17 AC.
VOL. 390, PG. 818

CURVE	DELTA ANGLE	RADIUS	ARC	TANGENT	CHORD	CHORD BEARING
C 1	54°04'18"	35.00'	33.03'	17.86'	31.82'	N 67°07'51"W
C 2	75°19'31"	30.00'	39.44'	23.16'	36.66'	S 48°10'14"W
C 3	75°19'31"	45.00'	59.16'	34.73'	54.99'	S 48°10'14"W
C 4	90°00'00"	5.00'	7.85'	5.00'	7.07'	N 40°50'00"E
C 5	12°46'20"	45.00'	10.03'	5.04'	10.01'	N 16°53'39"E
C 6	62°33'11"	45.00'	49.13'	27.34'	46.73'	N 54°33'24"E
C 15	90°00'00"	10.00'	15.71'	10.00'	14.14'	N 49°10'00"W

(SEE PAGE 1 OF 1)

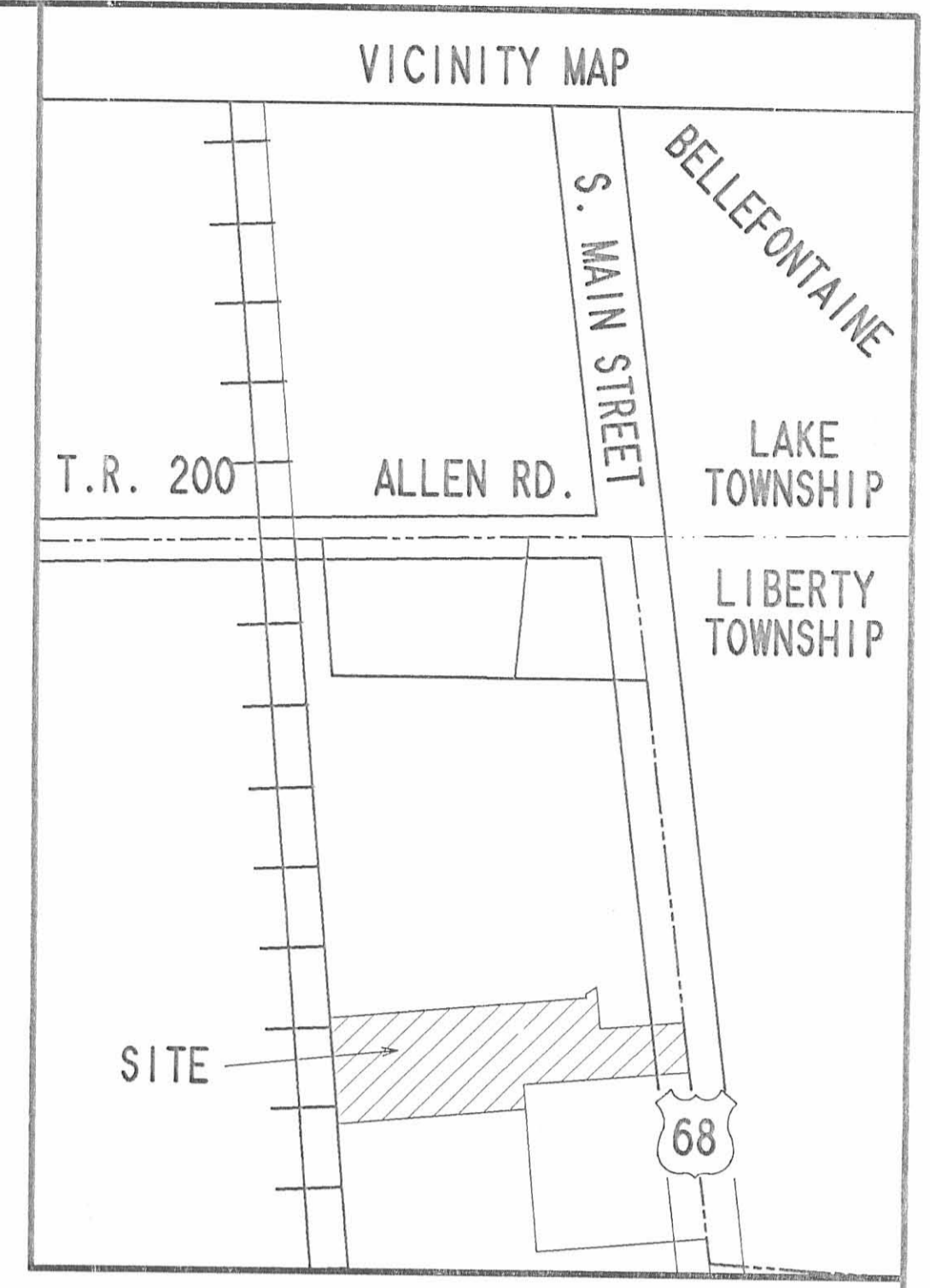
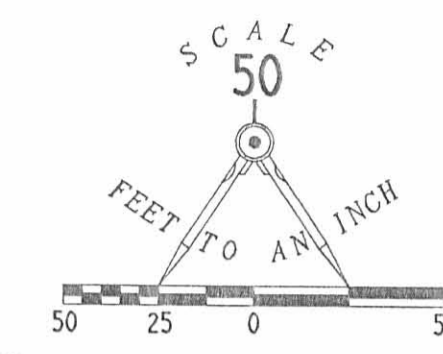

- 5/8" IRON ROD SET W/ PLASTIC I.D. CAP STAMPED "LEE P66359"
- 5/8" IRON ROD FOUND
- 1" METAL PIPE FOUND
- ⊙ RAILROAD SPIKE SET
- ⊙ RAILROAD SPIKE FOUND
- ⊙ P.K. NAIL SET

REFERENCES
LOGAN COUNTY ENGINEER'S SURVEY RECORDS, DRAWER R, FILE NUMBERS 1638, 777, 2821, 1384, 4314, 3737, AND 2907.
C.C.C. & ST. LOUIS RY. CO. STATION MAP, STA. 5248+60 TO 5289+71, DATED JUNE 30, 1915.

ALTA/ACSM LAND TITLE SURVEY OF
THREE TRACTS OUT OF THE
VENTURE PROPERTIES I. LLC. LTD
9.392 ACRE TRACT
OFFICIAL RECORD 259, PAGE 828
AND A 0.931 ACRE TRACT OUT OF THE
WILSON ANDERSON ORIGINAL 72.17 ACRE TRACT
VOLUME 390, PAGE 818
SECTION 32, TOWN 4, RANGE 14
CITY OF BELLEFONTAINE
LIBERTY TOWNSHIP
LOGAN COUNTY, OHIO

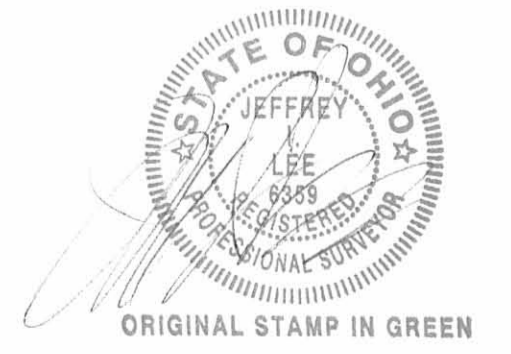

ORIGINAL STAMP IN GREEN
COPYRIGHT 1995 BY:
LEE SURVEYING & MAPPING CO.
143 East Columbus Avenue
BELLEFONTAINE, OHIO 43311
(513) 593-7335
D262 PLASALTA L 435-1

2 WORKING DAYS
BEFORE YOU DIG
CALL TOLL FREE 800-362-2764
OHIO UTILITIES PROTECTION SERVICE.

INDEXED ON MAP
24771 10P



Lee Surveying and Mapping Co., Inc.



Farm Surveys • Lot Surveys • Topography • Subdivisions • Construction Layout

143 EAST COLUMBUS AVENUE
BELLEFONTAINE, OHIO 43311

(513) 593-7335
FAX (513) 593-7444

VENTURE PROPERTIES I, LLC, LTD.

Lying in Section 32, Town 4, Range 14, City of Bellefontaine, Liberty Township, Logan County, Ohio.

Being over part of the Venture Properties I, LLC, Ltd. 5.613 acre tract as deeded and described in Official Record 259, Page 822, part of the 1.037 acre tract as deeded and described in Official Record 259, Page 825, and part of the 3.220 acre tract as deeded and described in Official Record 259, Page 819, with the referenced deeds being as filed in the Logan County Records of Deeds and being more particularly described as follows:

Beginning at a railroad spike found at the intersection of the north line of Section 32, the center-line of Allen Road and the center-line of South Main Street (U.S. Route 68) in the City of Bellefontaine.

THENCE, with the center-line of South Main Street, S 4°-10'-00" E, a distance of 339.94 feet to a PK nail set at the northeast corner of the said 3.220 acre tract.

THENCE, with the north line of the said 3.220 acre tract, N 86°-01'-28" W, a distance of 30.31 feet to a point on the west right-of-way of South Main Street and the TRUE POINT OF BEGINNING.

THENCE, with the west right-of-way of South Main Street (U.S. Route 68) and 30.00 feet west of the original center-line, S 4°-10'-00" E, a distance of 739.78 feet to a point.

THENCE, with the south line of the Venture Properties I, LLC, LTD 1.037 acre tract, S 85°-50'-00" W, a distance of 10.00 feet to a 5/8 inch iron rod set.

THENCE, through the aforesaid 1.037 acre, 5.613 acre, and 3.220 acre tracts, N 4°-10'-00" W, a distance of 741.21 feet to a 5/8 inch iron rod set.

THENCE, with the north line of the said 3.220 acre tract, S 86°-01'-28" E, a distance of 10.10 feet to the point of beginning.

Containing 0.170 acre. This description is not a boundary survey as defined in 4733-37 of the Ohio Administrative Code and shall not be used for anything other than to describe an easement.

The basis for bearings is based upon the center-line of South Main Street (U.S. Route 68) being S 4°-10'-00" E, and all other bearings are from angles and distances measured in a field survey by Lee Surveying and Mapping Company on December 4, 1995.

Description prepared by:

Jeffrey I. Lee
Professional Surveyor 6359
December 5, 1995



L 435

INDEXED ON MAP
8977 11D

ORIGINAL STAMP IN GREEN



Lee Surveying and Mapping Co.



Farm Surveys • Lot Surveys • Topography • Subdivisions • Construction Layout

143 EAST COLUMBUS AVENUE
BELLEFONTAINE, OHIO 43311

(513) 593-7335

JEFFREY L. LEE, P.S.

COMBINED PARCELS DESCRIPTION FOR LOWE'S 18.598 ACRES

Lying in Section 32, Town 4, Range 14, Liberty Township, Logan County, Ohio.

Being out of the Thomas and Marker Construction Company 11.00 acre and 6.95 acre tracts as deeded and described in Volume 331, Page 332; all of the Fred L. Allen and Janet P. Allen 2.07 acres as deeded and described in Volume 323, Page 87, the 0.151 acre as deeded and described in Volume 393, Page 631, the remainder of the original 1.039 acre as deeded and described in Volume 400, Page 589, and the 0.90 acre as deeded and described in Official Record 196, Page 516; and part of the Wilson Anderson original 72.17 acre tract as deeded and described in Volume 390, Page 818 with all of the referenced deeds being from the Logan County Records of Deeds and being more particularly described as follows:

Beginning at a railroad spike found at the intersection of the north line of Section 32, the center-line of Allen Road (Township Road 200) and the center-line of South Main Street (U.S. Route 68) in the City of Bellefontaine.

THENCE, with the north line of Section 32, N 85°-51'-18" W, a distance of 1007.84 feet to a railroad spike set at the TRUE POINT OF BEGINNING.

THENCE, S 0°-59'-51" W, a distance of 339.95 feet to a 5/8 inch iron rod set, passing a 5/8 inch iron rod set at 20.03 feet.

THENCE, S 86°-01'-28" E, a distance of 738.13 feet to a 5/8 inch iron rod found at the southwest corner of the Bob Evans Farms, Inc. 0.959 acre tract (O.R. 176, Pg. 37).

THENCE, with the south line of the said 0.959 acre tract and a south line of the City of Bellefontaine corporation, S 86°-01'-28" E, a distance of 300.19 feet to a PK nail found at an angle in the corporation line.

THENCE, with the center-line of U.S. Route 68 and a west line of the City of Bellefontaine Corporation, S 4°-10'-00" E, a distance of 473.00 feet to a PK nail set at the southeast corner of the aforementioned 0.90 acre tract.

THENCE, with the center-line of U.S. Route 68 and a west line of the City of Bellefontaine Corporation, S 4°-10'-00" E, a distance of 76.95 feet to a PK nail set.

THENCE, S 85°-50'-00" W, a distance of 30.00 feet to a 5/8 inch iron rod set.

THENCE, with a non-tangent curve to the left having a central angle of 54°-04'-18", a radius of 35.00 feet, an arc length of 33.03 feet on a chord bearing N 67°-07'-51" W, a chord distance of 31.82 feet to a 5/8 inch iron rod set.

THENCE, S 85°-50'-00" W, a distance of 139.04 feet to a 5/8 inch iron rod set.

THENCE, with a curve to the left having a central angle of 75°-19'-31", a radius of 30.00 feet, an arc length of 39.44 feet on a chord bearing S 48°-10'-14" W, a chord distance of 36.66 feet to a 5/8 inch iron rod set.

THENCE, with a curve to the right having a central angle of 75°-19'-31", a radius of 45.00 feet, an arc length of 59.16 feet on a chord bearing S 48°-10'-14" W, a chord distance of 54.99 feet to a 5/8 inch iron rod set.

THENCE, S 85°-50'-00" W, a distance of 3.00 feet to a 5/8 inch iron rod set.

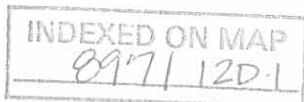



Lee Surveying and Mapping Co.



Farm Surveys • Lot Surveys • Topography • Subdivisions • Construction Layout

143 EAST COLUMBUS AVENUE
BELLEFONTAINE, OHIO 43311

(513) 593-7335

JEFFREY I. LEE, P.S.

THENCE, with a curve to the left having a central angle of $90^{\circ}-00'-00''$, a radius of 5.00 feet, an arc length of 7.85 feet on a chord bearing $S\ 40^{\circ}-50'-00''\ W$, a chord distance of 7.07 feet to a 5/8 inch iron rod set.

THENCE, $S\ 4^{\circ}-10'-00''\ E$, a distance of 13.00 feet to a 5/8 inch iron rod set.

THENCE, $S\ 85^{\circ}-50'-00''\ W$, a distance of 908.66 feet to a 5/8 inch iron rod set.

THENCE, with the east line of the Conrail properties, $N\ 0^{\circ}-59'-51''\ E$, a distance of 309.29 feet to a 5/8 inch iron rod set at the southwest corner of the aforementioned 11.0 acre tract.

THENCE, with the east line of the Conrail Properties and the west line of the aforesaid 11.0 acre tract, $N\ 0^{\circ}-59'-51''\ E$, a distance of 803.38 feet to a railroad spike set, passing a 5/8 inch iron rod set at 783.35 feet.

THENCE, with the north line of Section 32, $S\ 85^{\circ}-51'-18''\ E$, a distance of 90.14 feet to the point of beginning.

Containing 18.598 acres of which:

9.765 acres are out of the Thomas and Marker Construction Company lands of which 2.791 acres are out of the 11.0 acre tract with 0.041 acre within the highway right-of-way.

6.974 acre is all of the 6.95 acre tract;

3.220 acres contain all of the aforementioned Fred L. Allen tracts of which 0.326 acre is within the highway right-of-way;

and 5.613 acres are out of the Wilson Anderson 72.17 acre tract of which 0.055 acre is within the highway right-of-way.

The basis for bearings is based upon the center-line of South Main Street (U.S. Route 68) being $S\ 4^{\circ}-10'-00''\ E$, and all other bearings are from angles and distances measured in a field survey by Lee Surveying and Mapping Company in February and June, 1995.

Description prepared by:

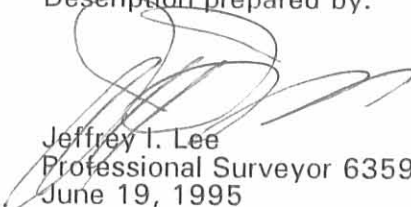
Jeffrey I. Lee
Professional Surveyor 6359
June 19, 1995



ORIGINAL STAMP IN GREEN

L 435

INDEXED ON MAP
897/120-2

3-19-2024



Tract 2
Legal Description
City of Bellefontaine, Township of Liberty, Logan County, Ohio
Section 32, Township 4N, Range 14W
0.680 Acres

Situated in the City of Bellefontaine, Township of Liberty, County of Logan, State of Ohio, Between the Miamis, Section 32, Township 4N, Range 14W, being part of an 18.322 acre tract conveyed to Lowe's Home Centers, Inc., recorded in Official Record 284, page 303, and more particularly bounded and described as follows:

Commencing for reference at a point in the centerline intersection of Gunntown Road and South Main Street (U.S. Route 68);

Thence with said centerline of South Main Street (Variable Right-of-Way), and the east line of a 0.465 acre tract, conveyed to The State of Ohio, recorded in Official Record 966, page 109, in the Logan County Recorders Office, **N02°29'32"W 181.09 feet** to a point;

Thence with a reference line through said 0.465 acre tract, **S87°30'28"W 42.50 feet** to an **Iron Pin Set**, being the **TRUE POINT OF BEGINNING**;

Thence with the west line of said 0.465 acre tract the following four (4) courses:

S02°29'32"E 126.01 feet to a **Right-of-Way Monument Found Stamped 7384**;

S29°01'29"W 31.41 feet to a **Right-of-Way Monument Found Stamped 7384**;

S18°26'04"E 5.47 feet to an **Iron Pin Set**; and

S01°19'04"E 6.99 feet to a **Mag Nail Set**;

Thence with a new line through said tract, **S87°21'58"W 138.20 feet** to a point from which an Iron Pin Set bears N11°03'15"W 2.79 feet;

Thence with a new line through said tract on a curve to the right having a radius of **30.0 feet**, an **arc distance of 47.27 feet**, delta 90°16'44", (the cord of which bears N47°29'40"W, 42.53 feet) to a point from which an Iron Pin Set bears N87°38'42"E 2.00 feet;

Thence with a new line through said tract, **N02°21'18"W 134.86 feet** to a point from which an Iron Pin Set bears N87°21'58"E 2.00 feet;

Thence with a new line through said tract, **N87°21'58"E 183.01 feet**, passing an **Iron Pin Set** for reference at 2.00 feet, to the **TRUE POINT OF BEGINNING**;

Containing **0.680 Acres**, more or less.

Subject to all existing rights-of-way and easements of record.



The bearings described herein are based on the Ohio State Plane Coordinate System, North Zone, NAD83 (2012) Epoch 2010. The portion of the centerline of South Main Street (U.S. Route 68), having a bearing of N02°29'32"W and monumented as described herein is designated the "basis of bearing" for this survey.

Iron Pins Set are 5/8" diameter x 30" long rebar with red plastic cap stamped "H&S 8592". I hereby certify that the foregoing legal description, together with the attached plat, is a true representation of the conditions as they existed on the date of the field survey, January 12, 2024, performed by Harral and Stevenson, LLC, under my direct supervision, and that the accuracy of same is consistent with accepted surveying standards.



Craig E. Stevenson P.S. 8592
Harral and Stevenson

March 19, 2024
Date

INDEXED ON MAP
0971

3-19-2024



Tract 1
Legal Description
City of Bellefontaine, Township of Liberty, Logan County, Ohio
Section 32, Township 4N, Range 14W
0.682 Acres

Situated in the City of Bellefontaine, Township of Liberty, County of Logan, State of Ohio, Between the Miamis, Section 32, Township 4N, Range 14W, being part of an 18.322 acre tract conveyed to Lowe's Home Centers, Inc., recorded in Official Record 284, page 303, and more particularly bounded and described as follows:

Commencing for reference at a point in the centerline intersection of Gunntown Road and South Main Street (U.S. Route 68);

Thence with said centerline of South Main Street (Variable Right-of-Way), and the east line of an 0.465 acre tract, conveyed to The State of Ohio, recorded in Official Record 966, page 109, in the Logan County Recorders Office, **N02°29'32"W 181.09 feet** to a point;

Thence with a reference line through said 0.465 acre tract, **S87°30'28"W 42.50 feet** to an **Iron Pin Set**, in the east line of the remainder of said 18.322 acre tract, being the **TRUE POINT OF BEGINNING**;

Thence with a new line through said 18.322 acre tract, **S87°21'58"W 183.01 feet** to a point, passing an **Iron Pin Set** for reference at 181.01 feet;

Thence with a new line through said tract, **N02°21'18"W 135.32 feet** to a point from which an Iron Pin Set bears N87°38'42"E 2.00 feet;

Thence with a new line through said tract on a curve to the right having a radius of **30.00 feet**, **an arc distance of 47.09 feet**, delta 89°56'07", (the cord of which bears N42°36'45"E, 42.40 feet) to a point from which an Iron Pin Set bears S02°25'08"E 0.50 feet;

Thence with a new line through said tract, **N87°34'52"E 112.73 feet** to a point from which a **Mag Nail Set** bears N87°34'52"E 39.92 feet;

Thence with a new line through said tract on a curve to the right having a radius of **56.01 feet**, **an arc distance of 45.98 feet**, delta 47°02'15", (the cord of which bears S65°45'07"E, 44.70 feet) to a point on the west line of above mentioned 0.465 acre tract, said point bears S02°29'35"E 20.06 feet from which a Mag Nail Set;

Thence with the west line of said 0.465 acre tract, **S02°29'32"E 144.54 feet** to the **TRUE POINT OF BEGINNING**;

Containing **0.682 Acres**, more or less.

Subject to all existing rights-of-way and easements of record.



The bearings described herein are based on the Ohio State Plane Coordinate System, North Zone, NAD83 (2012) Epoch 2010. The portion of the centerline of South Main Street (U.S. Route 68), having a bearing of N02°29'32"W and monumented as described herein is designated the "basis of bearing" for this survey.

Iron Pins Set are 5/8" diameter x 30" long rebar with red plastic cap stamped "H&S 8592". I hereby certify that the foregoing legal description, together with the attached plat, is a true representation of the conditions as they existed on the date of the field survey, January 12, 2024, performed by Harral and Stevenson, LLC, under my direct supervision, and that the accuracy of same is consistent with accepted surveying standards.



Craig E. Stevenson P.S. 8592
Harral and Stevenson

March 18, 2024
Date

INDEXED ON MAP
8971

3-19-2024

APPROVED

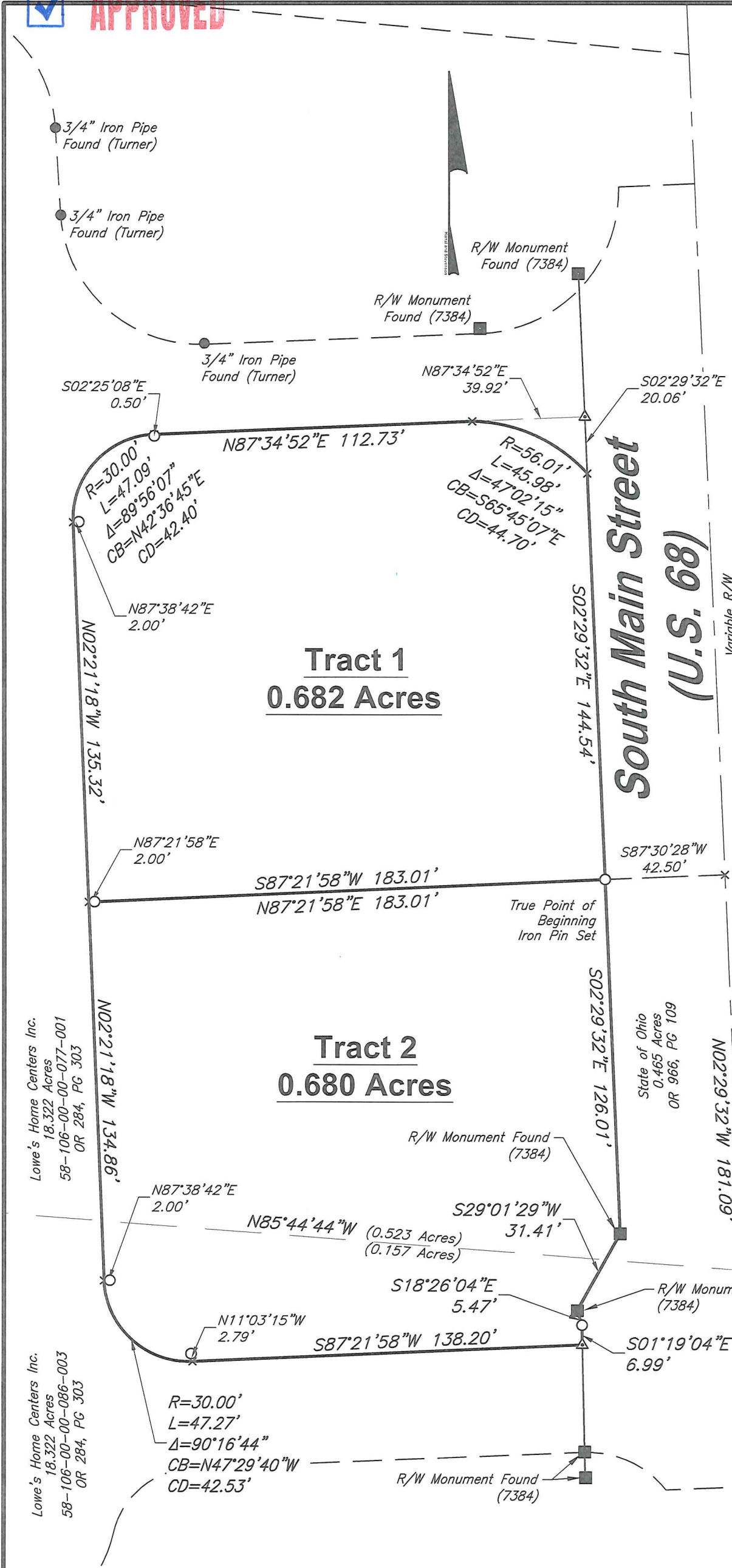

IRON PINS SET ARE 5/8" DIAMETER X 30" LONG REBAR WITH RED PLASTIC CAP STAMPED "H&S 8592". ALL IRON PINS SHOWN AS FOUND ARE IN GOOD CONDITION UNLESS NOTED OTHERWISE.

BEARING REFERENCE:
THE BEARINGS SHOWN ON THIS PLAT ARE BASED ON THE OHIO STATE PLANE COORDINATE SYSTEM, NORTH ZONE, NAD83 (2011) EPOCH 2010. THE PORTION OF THE CENTER LINE OF SOUTH MAIN STREET (US 68), HAVING A BEARING OF N02°29'32"W, IS DESIGNATED THE "BASIS OF BEARING" FOR THIS SURVEY.

REFERENCE DOCUMENTS:
OR 284 PG 303

I HEREBY CERTIFY THAT THE ATTACHED PLAT, IS A TRUE REPRESENTATION OF A SURVEY PERFORMED (January, 2024) BY HARRAL AND STEVENSON, LLC UNDER MY DIRECT SUPERVISION AND THAT THE ACCURACY OF SAID SURVEY IS CONSISTENT WITH OHIO ADMINISTRATIVE CODE 4733-37 AND MEETS OR EXCEEDS LOGAN COUNTY CONVEYANCE STANDARDS.

Craig E. Stevenson
 CRAIG E. STEVENSON, PS 8592

3/19/2024
DATE



Lowe's Home Centers Inc.
18.322 Acres
58-106-00-00-077-001
OR 284, PG 303

Lowe's Home Centers Inc.
18.322 Acres
58-106-00-00-086-003
OR 284, PG 303

Symbol Legend

- Iron Pin Found
- R/W Monument Found
- Iron Pin Set
- ▲ Mag Nail Set
- × Point

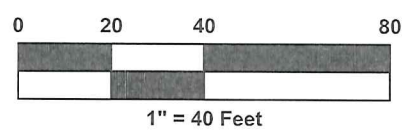

INDEXED ON MAP
8971

Harral and Stevenson
Civil Engineering and Surveying
2869 North Court Street
Circleville, Ohio 43113
Ph: 740.497.4432
www.harralstevenson.com

CITY OF BELLEFONTAINE, LIBERTY TOWNSHIP, LOGAN COUNTY, OHIO
SECTION 32, TOWNSHIP 4N, RANGE 14W

PLAT OF SURVEY

SCHIFF PROPERTIES

Project No: S0882	Scale: 1" = 40'
Client: Jared Schiff	Drawn: EGC
Date: March 18, 2024	Reviewed: CES