

# Lee Surveying and Mapping Co.



Farm Surveys • Lot Surveys • Topography • Subdivisions • Construction Layout

855 EAST SANDUSKY AVENUE  
BELLEFONTAINE, OHIO 43311

(513) 593-5780

CLAYTON M. LEE, P.S.  
JEFFREY I. LEE, P.S.

## CONRAIL TO M. & B. INVESTMENTS (CASE 69263)

Lying in the City of Bellefontaine, Section 35, T-4, R-14, Lake Township, Logan County, Ohio.

Being out of the CONRAIL properties as described in Volume 378, Page 333 of the Logan County Records of Deeds and being more particularly described as follows:

Beginning at a 5/8" iron rod found on the north line of West Sandusky Avenue, a distance of 32.08 feet, westerly, with said north street line, from the center-line of Everett Street.

THENCE, continuing with the north line of West Sandusky Avenue, N 76°-47'-45" W, a distance of 89.42 feet to a 5/8" iron rod (set).

THENCE, with the south line of the said CONRAIL property, the following 2 bearings and distances:

N 47°-17'-00" W, 167.18 feet to a 5/8" iron rod (set).

S 42°-37'-03" W, 20.00 feet to a 5/8" iron rod set on the west line of City Lot No. 732 on the south line of Railroad Street.

THENCE, N 47°-10'-43" W, with the north line of City Lots No. 404, 405, 406, and 407, a distance of 333.57 feet to a 5/8" iron rod (set).

THENCE, S 13°-56'-58" W, with the west line of Lot No. 407, a distance of 14.80 feet to a 1" iron pipe (found).

THENCE, N 76°-47'-45" W, 34.49 feet to a 5/8" iron rod (set).

THENCE, N 47°-10'-43" W, 147.72 feet to a 5/8" iron rod set on the east line of West Street.

THENCE, with the said east line of West Street, N 13°-56'-56" E, a distance of 106.25 feet to a 'PK' spike set on the southwest corner of the Hemmelgarn lot (O.R. 66, Page 3, Tract 5).

THENCE, with the south line of a tier of lots facing Garfield Avenue, S 47°-17'-00" E, a distance of 800.28 feet to the point of beginning.

Containing 1.114 acres.

This description prepared from an actual field survey.

Basis for bearings: Center-line of West Sandusky Avenue = N 86°-47'-45" W.

Prepared by:

Clayton M. Lee  
Registered Professional Surveyor No. 6181  
November 14, 1988

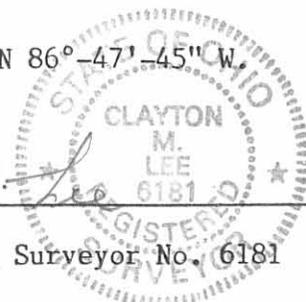

INDEXED ON MAP  
6216 ID

ADJOINING PROPERTIES

- (A) L. HEMMELGARN - O.R. 66, PG. 3, TR. V
- (B) R. GRADSKY - VOL. 303, PG. 605
- (C) L. HEMMELGARN - O.R. 66, PG. 3, TR. IV
- (D) L. HEMMELGARN - O.R. 66, PG. 3, TR. III
- (E) L. HEMMELGARN - O.R. 66, PG. 3, TR. II
- (F) L. HEMMELGARN - O.R. 66, PG. 3, TR. I
- (G) PENN CENTRAL - VOL. 378, PG. 340  
RAILROAD STREET EXTENDED ACROSS  
LOT 732 - ORD. BK "0", 1897.

INDEXED ON MAP  
6216 1P

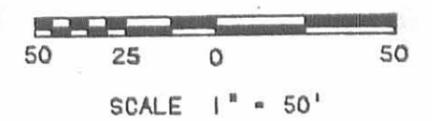

LEGEND  
 ● 5/8" IRON ROD SET  
 ○ 1" PIPE FOUND  
 ○ 5/8" IRON ROD FOUND  
 ● PK NAIL SET

| LINE | BEARING         | DISTANCE |
|------|-----------------|----------|
| L 1  | S 42° 37' 03" W | 20.00    |
| L 2  | S 13° 56' 56" W | 14.80    |
| L 3  | N 76° 47' 45" W | 34.49    |

SURVEY OF 1.114 ACRES FOR  
 M & B INVESTMENTS (CASE 69263)  
 OUT OF THE CONRAIL PROPERTIES  
 (VOL. 378, PG. 333)  
 PART OF CITY LOTS 408; 409, 410, 732  
 AND SECTION 35, T-4, R-14, B.M.S.  
 CITY OF BELLEFONTAINE  
 LAKE TOWNSHIP, LOGAN COUNTY, OHIO

STATE OF OHIO  
 SURVEYED BY:  
 JEFFREY T. LEE  
 REGISTERED SURVEYOR NO. 6359  
 NOVEMBER 10, 1988  
 ORIGINAL STAMP IN GREEN  
**Lee Surveying & Mapping Co.**  
 855 E. Sandusky Ave.  
 BELLEFONTAINE, OHIO 43311  
 (513) 593-5780

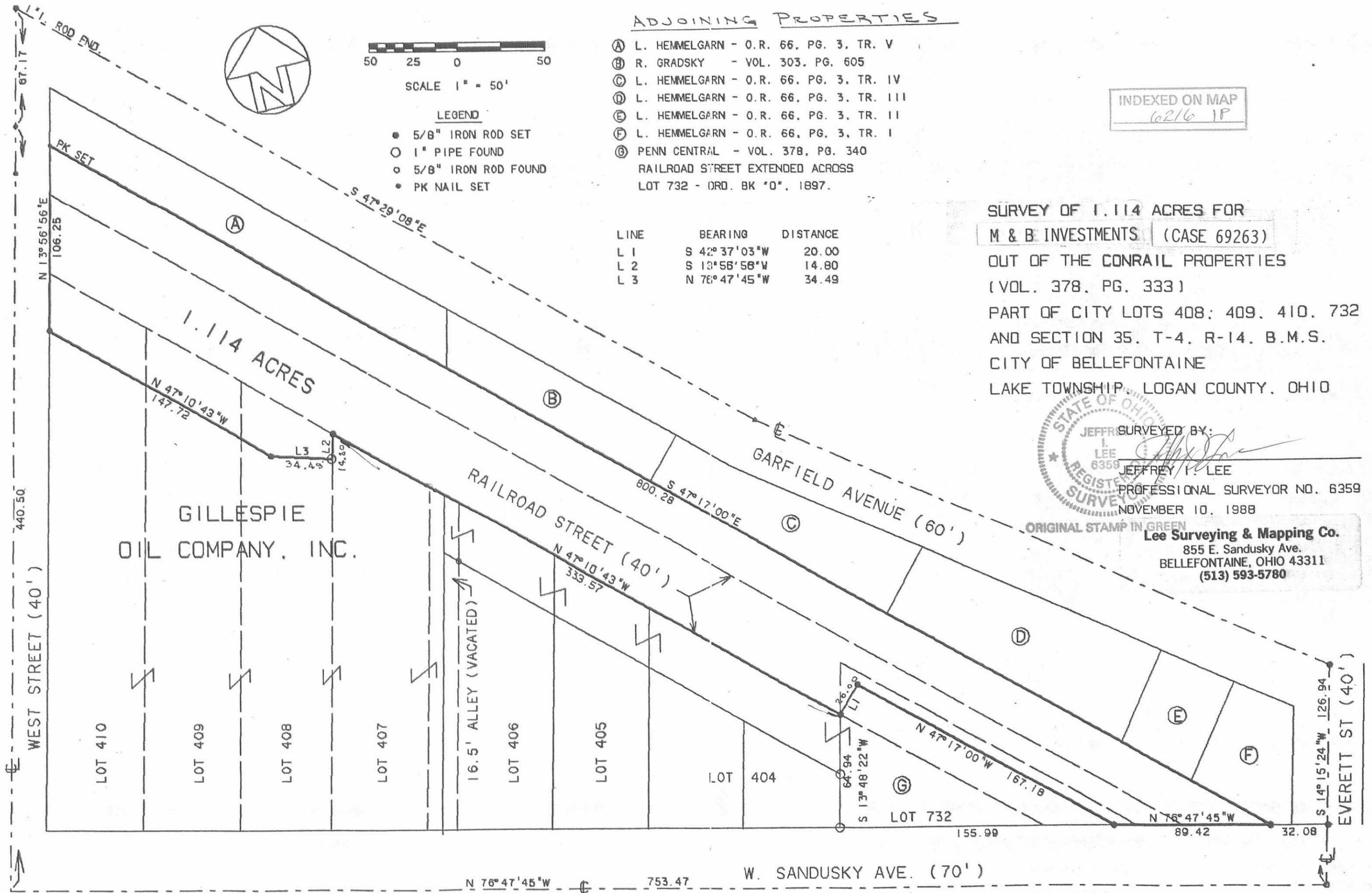

Received 2-21-86

0A(CR)

DANIEL E. GILBERT, P.S.  
REG. SUR. NO. 5402  
105 ORGAN STREET  
BELLEFONTAINE, OHIO 43311

Penn Central Corporation  
to  
Larry Kussmaul Survey

I. D. No. OH. D000-M79 (Part).

The following described real estate situated in the Village of Huntsville, Township of McArthur, County of Logan, State of Ohio and being a part of Virginia Military Survey No. 9904 and being more particularly described as follows:

Beginning at the southeast corner to the old "Knights of Pythias" hall, which is a two story brick building located on the north line of Napoleon Street (60 feet wide) and the west right of way line of the original Madriver and Lake Erie Railroad Company (later C. S. & C. RR.), now Penn Central Corporation, said building now in the name of Howard H. Snapp et al (Deed Volume 378 Page 244 [5-19-1978]);

Thence with the west right of way line of said railroad, N. 14°-43'-40" E. 156.95 feet to an iron pipe found at the northeast corner to John Hejduk's present 0.03 Acre tract and the southeast corner to the Village of Huntsville's present 1.87 Acre tract;

Thence continuing with the west right of way line of said railroad, N. 15°-51'-38" E. 532.25 feet to an iron bar set, passing the center of the Huntsville Ditch at 376.78 feet, said center of said ditch being the northeast corner to said Village of Huntsville's 1.87 Acre tract and the southeast corner to Steven Hall's present 1.75 Acre tract;

Thence S. 74°-22'-08" E. 83.29 feet to an iron bar set in the east right of way fence line of said railroad and the west line of Albert J. Smith, Jr's. present 16.709 Acre tract, passing through an iron bar set in the centerline of said railroad property at 50.13 feet;

Thence with Smith's west line and the east right of way fence line of said railroad, S. 15°-58'-08" W. 53.09 feet to a concrete corner post, the southwest corner to Smith's tract;

Thence S. 74°-22'-08" E. 17.18 feet to an iron bar set at the northeast corner to Charles W. Bland's present 0.911 Acre tract and being the east right of way line of said railroad property;

Thence with the east right of way line of said railroad property, S. 15°-37'-52" W. 637.75 feet to an iron bar set in the north line of Napoleon Street, passing through an iron pipe found at 288.31 feet and a R. R. Spike in a tree root at 420.25 feet;

Thence with the north line of Napoleon Street, N. 73°-24'-55" W. 99.81 feet to the place of beginning, passing through an iron bar set in the centerline of said railroad right of way at 50.01 feet, containing 68,905.66 square feet or 1.582 Acres, more or less.

I hereby certify that the above description is the result of a field survey made by me on February 15, 1986.

INDEXED ON MAP  
6216 2D



*Daniel E. Gilbert*  
Daniel E. Gilbert, P.S.  
Reg. Sur. No. 5402

Albert J. Smith, Jr. et al  
Vol. 369 Page 559 (3-28-1977)

16.709 Acres

Per. Par. No. 24-048-00-00-033

Charles W. Bland et ux  
Vol. 381 Page 283 (11-13-1979)

0.911 Acres

Per. Par. No. 24-048-11-08-001

Willoby Alley

Alley - 16.5'

William Cousins et ux  
Vol. 19C Page 171 (8-3-1946)

Per. Par. No. 24-048-11-08-002  
26

Per. Par. No. 24-048-11-08-003  
27  
ADDITION  
Slide 159

Per. Par. No. 24-048-11-08-004  
28

Larry E. Kusssmaul et ux  
Vol. 399 Page 154 (2-24-1983)

0.52 Acres

Per. Par. No. 24-048-11-08-005

PENN CENTRAL CORPORATION

Steven Hall et ux  
Vol. 387 Page 840 (5-9-1980)  
1.75 Acres  
Per. Par. No. 24-048-11-07-014

Bridge No. 199  
Sta. 4837+78  
Plan V-42, Page 24  
C. S. & C. RR.  
6' Concrete Box Culvert  
63' Long.

68,905.66' or 1.582 Acres  
I. D. No. OH. D000-1479 (Part)

The Village of Huntsville, Ohio  
Vol. 282 Page 385 (9-25-1961)  
1.87 Acres  
Per. Par. No. 24-048-11-07-012

Vacated Alley 16.5' Ordinance No. 476 (8-11-1984)

STREET - 60'

NAPOLEON STREET



PENN CENTRAL CORPORATION  
TO  
LARRY KUSSMAUL SURVEY  
V. M. S. NO. 9904  
VILLAGE OF HUNTSVILLE  
M. ARTHUR TOWNSHIP  
LOGAN COUNTY, OHIO  
FEBRUARY 15, 1986

SCALE: 1" = 40'

This survey certified as to correctness to "The Penn Central Corporation" and the title insurance company insuring their interests in the premises.



*Daniel E. Gilbert*  
Daniel E. Gilbert, P.S.  
Ohio Reg. Sur. No. 5402  
105 Organ Street  
Bellefontaine, Ohio 43311

Note:  
● = 5/8" x 30" Rebars Set. (Capped)

INDEXED ON MAP  
6216 2P

John Hejduk  
O.R. Vol. 10 Page 286  
(8-12-1985) 0.0331 Acres  
Per. Par. No. 24-048-11-07-011

John G. Hejduk  
Vol. 382 Page 320 (5-2-1979)  
0.12 Acres  
Per. Par. No. 24-048-11-07-003

Howard H. Snapp et al  
Vol. 378 Page 244 (5-19-1978)  
0.136 Acres  
Per. Par. No. 24-048-11-07-010

156.95'  
Old "Knights of Pythias" Hall,  
Two Story Brick Building

Note: Magnetic Bearings from previous recorded surveys.



JEFFREY I. LEE, Professional Land Surveyor  
1160 Michigan Avenue  
Bellefontaine, Ohio 43311



CON-RAIL TO ABRAHAM

Lying in the City of Bellefontaine, Section 35, T-4, R-14, Lake Township, Logan County, Ohio. (PAGE 1).

Being a section of abandoned railroad right-of-way in the name of Consolidated Rail Corporation as recorded in Volume 378, Page 360 of the Logan County Records of Deeds and being more particularly described as follows:

Beginning at a railroad spike set at the intersection of the east line of Everett Street (40 feet wide) and the south line of Sandusky Avenue. This point being on the west line of the railroad company's Parcel No. 47 (Volume 95, Page 411).

THENCE, with the said south line of Sandusky Avenue, S 76°-47'-45" E, a distance of 73.00 feet to a 5/8" iron rod set on the north line of Parcel No. 33 (C.C.C. & St. L. Railroad) (Volume 95, Page 426).

THENCE, with the north line of said Parcel 33, the same being the south line State of Ohio 0.28 acre tract (Volume 328, Page 555), S 47°-17' E, a distance of 142.63 feet to a 5/8" iron rod set on the west line of Parcel No. 34 (Volume 101, Page 458).

THENCE, with the east line of said 0.28 acre tract, N 38°-59' E, a distance of 22.80 feet to a 3/4" iron rod found at the southwest corner of the Oberlander lot (O.R. 15, Page 782).

THENCE, with the south line of said Oberlander lot and continuing with the south line of the Clara Brown lots (Volume 351, Page 287 and Volume 372, Page 754), S 49°-38'-20" E, a distance of 237.24 feet to a 2" steel rod found on the west line of the Clara Brown 0.06 acre lot (Volume 373, Page 942).

THENCE, with the west line of said 0.06 acre lot, S 35°-14'-45" W, a distance of 34.10 feet to a 5/8" iron rod set at its southwest corner.

THENCE, with the south line of the said 0.06 acre lot and the south line of the Leroy Jauret lot (Volume 386, Page 864) and the south line of a 12 foot wide alley, S 46°-05'-15" E, a distance of 285.08 feet to a 3/4" iron rod found at the point where said 12 foot wide alley turns northerly.

THENCE, with the east line of said 12 foot wide alley, N 43°-07'-45" E, a distance of 17.72 feet to the southwest corner of the Abraham lot (Volume 319, Page 888, Tract III). (5/8" iron rod).

THENCE, with the said Abraham lot and the Abraham lots described in Volume 319, Page 890 (Parcel II, Tract I) and Volume 218, Page 153 (Tract II) the following 3 bearings and distances:  
S 41°-50'-50" E, 126.84 feet to a 5/8" iron rod.  
S 47°-10'-20" E, 64.92 feet to a 5/8" iron rod.  
S 76°-35'-20" E, 41.51 feet to a 2" iron pipe found at the northwest corner of the Tudor Electric Company's 0.22 acre lot (Volume 323, Page 579).

THENCE, with the west line of the said 0.22 acre lot, S 13°-29'-25" W, 39.67 feet to a 5/8" iron rod set on the north line of West Columbus Avenue.

THENCE, with the said north street line, N 76°-36'-30" W, a distance of 91.83 feet to a 5/8" iron rod set on the east corner of the Irick 0.10 acre lot (Volume 385, Page 489).

THENCE, with the north line of the said Irick 0.10 acre lot and the Irick 0.12 acre lot (Volume 383, Page 403) and the north line of the Finley 0.14 acre lot (Volume 396, Page 229), N 45°-48'-10" W, a distance of 260.29 feet to a 5/8" iron rod set at the northeast corner of the railroad company's Parcel No. 34 (Volume 101, Page 458).

THENCE, with the boundary of said Parcel 34, the following 5 bearings and distances:  
S 14°-35'-20" W, 49.32 feet to a 5/8" iron rod.  
N 75°-24'-40" W, 3.75 feet to a 5/8" iron rod.  
S 14°-35'-20" W, 88.00 feet to a 5/8" iron rod on the north line of Columbus Avenue.  
N 76°-36'-30" W, with said north line, 27.75 feet to a 5/8" iron rod.  
N 13°-23'-30" E, 125.76 feet to a 5/8" iron rod.



JEFFREY I. LEE, Professional Land Surveyor  
 1160 Michigan Avenue  
 Bellefontaine, Ohio 43311



CON-RAIL TO ABRAHAM (continued)

(PAGE 2).

THENCE, with the north line of the Finley 0.21 acre lot, (Volume 396, Page 229), N 51°-03'-05" W, a distance of 56.97 feet to a 5/8" iron rod.

THENCE, with the west line of said 0.21 acre lot, S 13°-31'-20" W, a distance of 5.55 feet to a 5/8" iron rod set at the northeast corner of the Branham 0.30 acre lot (O.R. 15, Page 774).

THENCE, with the north line of said 0.30 acre lot, N 49°-19'-15" W, a distance of 73.99 feet to a 5/8" iron rod set on the east line of the Belfry 0.21 acre lot (Volume 395, Page 805).

THENCE, with the east line of said 0.21 acre lot, N 14°-13'-10" E, a distance of 5.59 feet to a 5/8" iron rod set at its northeast corner.

THENCE, with the north line of the said 0.21 acre lot and the north lines of the following 4 lots: McGinnis (O.R. 21, Page 736, Tract I and Tract II; Hill (Volume 299, Page 631; Kelly (Volume 326, Page 347), N 49°-13'-50" W, a distance of 224.16 feet to a 1 1/2" iron pipe found at the northeast corner of the Gillespie Oil Company land (Volume 321, Page 311).

THENCE, with the north line of said Gillespie Oil Company land, the following 3 bearings and distances:

N 47°-29' W, 145.09 feet to a 1" iron pipe (Found).

N 42°-01'-15" E, 10.00 feet to a 1" iron pipe (Found).

N 47°-23'-40" W, 86.52 feet to a 1" iron pipe found on the east line of Everett Street.

THENCE, with said east street line, N 14°-14'-15" E, a distance of 52.60 feet to the point of beginning.

Containing 1.866 acres (81,298 square feet)

This description embraces the original C.C.C. & St. L. Parcels 33 and 34 and Parcels 33 through 48 of the T. & O.C. Railroad.

This description prepared from an actual field survey.

Basis for bearings: South line of East Sandusky Avenue (S 76°-47'-45" E).

Prepared by:

Jeffrey I. Lee  
 Registered Professional Surveyor No. 6359  
 December 15, 1986



ORIGINAL STAMP IN GREEN

INDEXED ON MAP

6216 3D-2

L-1514

I.D. NO. OHDO9008-7  
LOGAN COUNTY, OHIO

LINE CODE 8147 & 8142  
VAL. SEC. 42 (B4) 303 (T & OC)

SCALE 1" = 40'

SANDUSKY AVE.

GARFIELD AVE.

EVERETT ST.

COLUMBUS AVE.

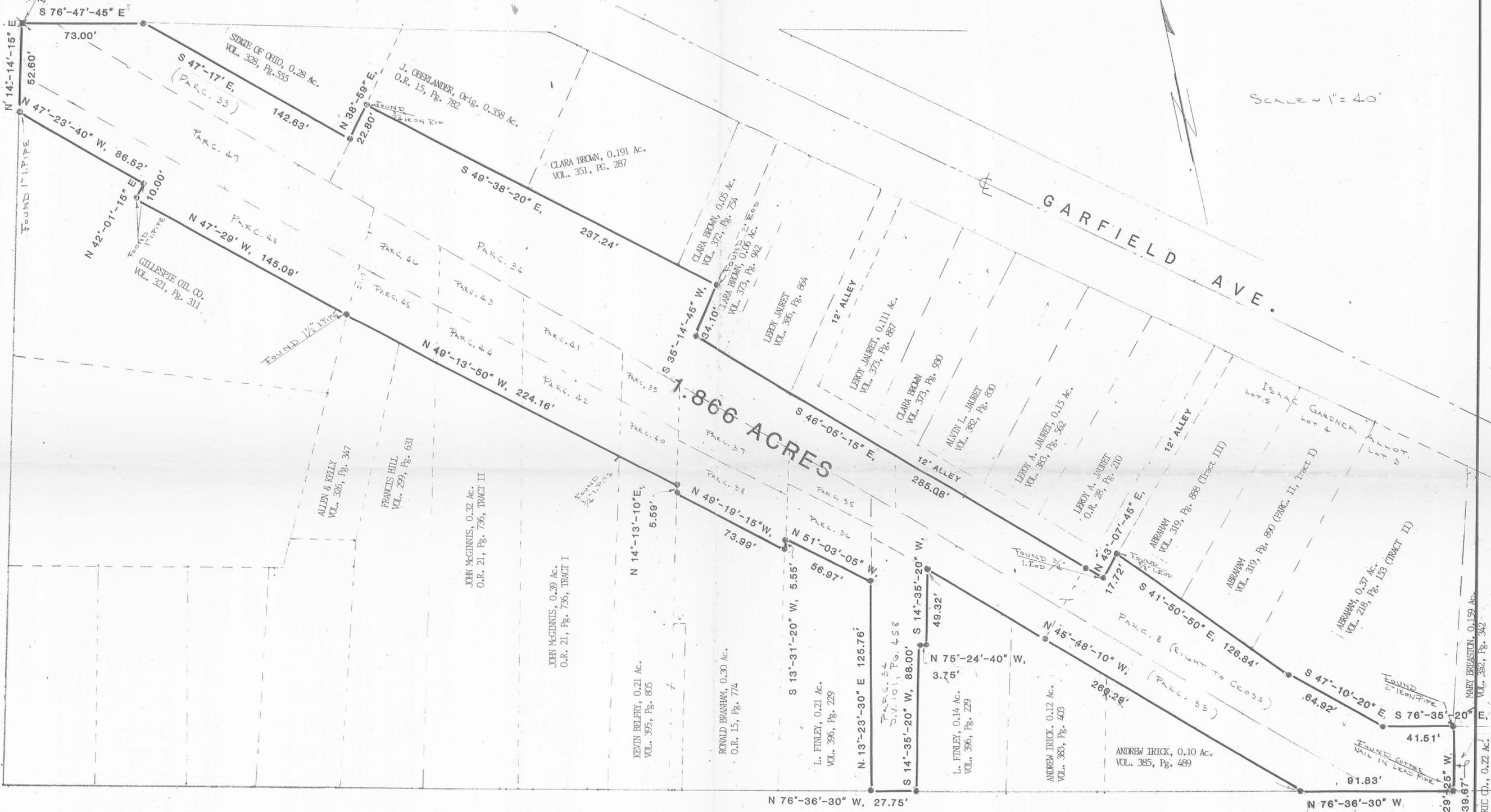

• = 5/8" IRON ROD SET (UNLESS OTHERWISE SHOWN)

**CON-RAIL TO ABRAHAM**  
 CITY OF BELLEFONTAINE  
 SECTION 35, T-4, R-14  
 LAKE TOWNSHIP,  
 LOGAN COUNTY, OHIO

SURVEYOR'S CERTIFICATION

This survey certified as to correctness to Mr. & Mrs. ABRAHAM and to CONSOLIDATED RAIL CORPORATION and to any title insurance company or any lender or any other persons with interests in the subject premises.

*Jeffrey I. Lee*  
 Jeffrey I. Lee  
 Professional Surveyor No. 6359  
 December 11, 1986



INDEXED ON MAP  
 6216 2P

ORIGINAL STAMP IN GREEN

# Lee Surveying and Mapping Co.



Farm Surveys • Lot Surveys • Topography • Subdivisions • Construction Layout

855 EAST SANDUSKY AVENUE  
BELLEFONTAINE, OHIO 43311

(513) 593-5780

CLAYTON M. LEE, P.S.  
JEFFREY I. LEE, P.S.

## RICHARD ABRAHAM SURVEY

Lying in the City of Bellefontaine, Section 35, T-4, R-14, Lake Township, Logan County, Ohio.

Being the east part of that 1.866 acre tract in the name of Abraham as deeded and described in O.R. 73, Page 359 of the Logan County Records of Deeds and being more particularly described as follows:

Beginning at a 5/8" iron rod set on the south line of the said 1.866 acre tract (Former railroad right-of-way) being N 45°-48'-10" W, a distance of 179.10 feet from the north line of West Columbus Avenue.

THENCE, N 43°-07'-45" E, a distance of 49.32 feet to a 5/8" iron rod set on the north line of said 1.866 acre tract at the southwest corner of a 12 foot wide alley.

THENCE, with the terminus of said alley, S 46°-05'-15" E, a distance of 12.00 feet to a 5/8" iron rod found on the southeast corner of said 12 foot alley.

THENCE, with the east line of said alley, N 43°-07'-45" E, a distance of 17.72 feet to a 5/8" iron rod found.

THENCE, with the boundary of said 1.866 acre tract, the following 6 bearings and distances:

S 41°-50'-50" E, a distance of 126.84 feet to a 5/8" iron rod (found)

S 47°-10'-20" E, a distance of 64.92 feet to a 5/8" iron rod (found).

S 76°-35'-20" E, a distance of 41.51 feet to a 2" iron pipe (found).

S 13°-29'-25" W, a distance of 39.67 feet to a copper nail in a lead pipe (found) on the north line of West Columbus Avenue.

N 76°-36'-30" W, with said north line, 91.83 feet to a 5/8" iron rod (found).

N 45°-48'-10" W, a distance of 179.10 feet to the point of beginning.

Containing 0.328 acres.

This description prepared from an actual filed survey.

Basis for bearings: North line of West Columbus Avenue = N 76°-36'-30" W.

Prepared by:

*Clayton M. Lee*  
Clayton M. Lee

Registered Professional Surveyor No. 6181  
October 25, 1988



INDEXED ON MAP  
6216 4D

L-1514



SCALE = 1" = 40'

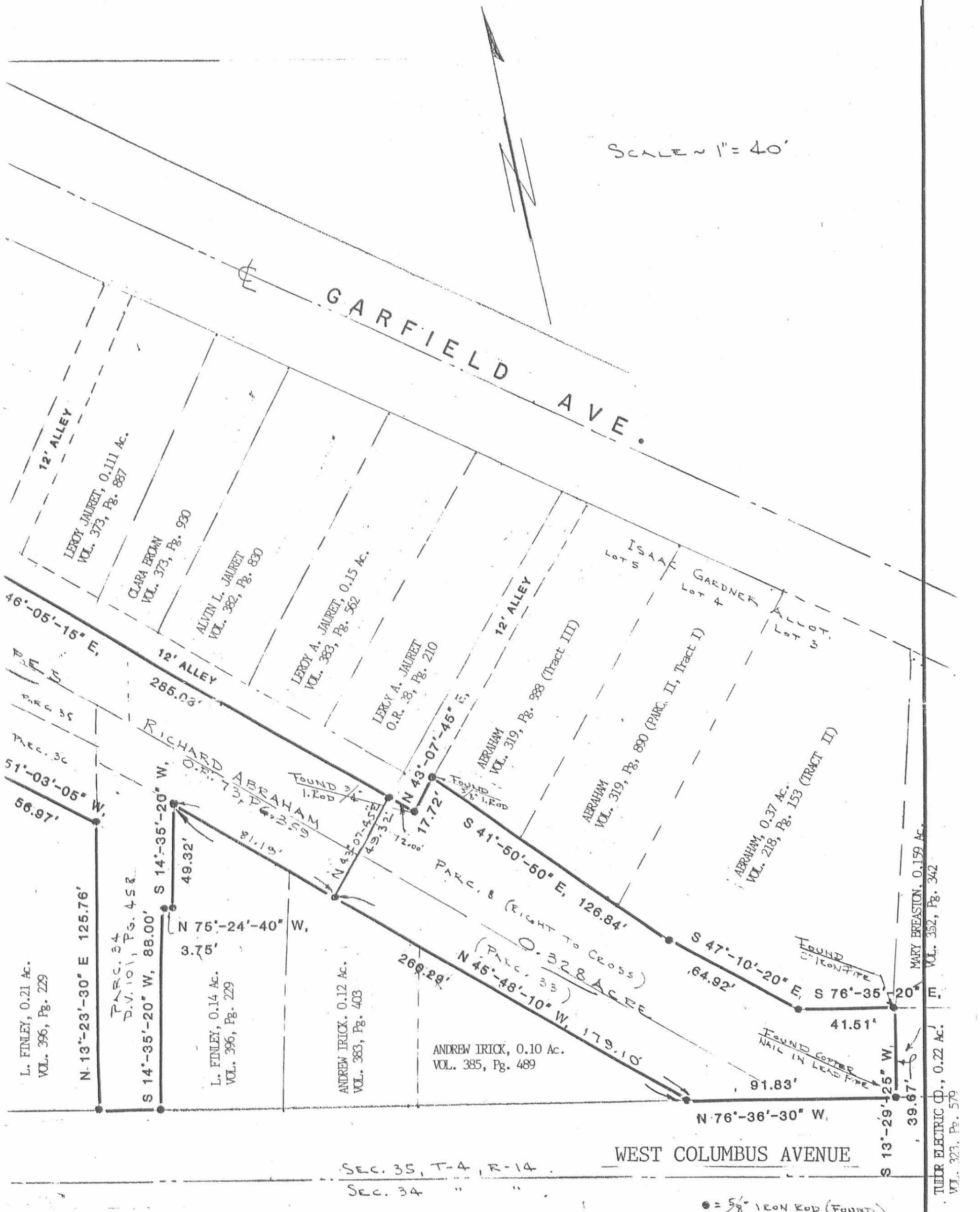

SURVEY OF 0.328 ACRE OUT OF ABRAHAM 1.866 ACRE TRACT  
 CITY OF BELLEFONTAINE, SECTION 35, T-4, R-14  
 LAKE TOWNSHIP, LOGAN COUNTY, OHIO

BY: *Jeffrey I. Lee*  
 Jeffrey I. Lee  
 Registered Professional Surveyor No. 6359  
 October 1988

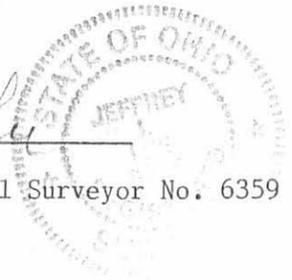

INDEXED ON MAP  
 6216 4P

REC'D 11-15-94 smy tk ✓



# Lee Surveying and Mapping Co.



Farm Surveys • Lot Surveys • Topography • Subdivisions • Construction Layout

143 EAST COLUMBUS AVENUE  
BELLEFONTAINE, OHIO 43311

(513) 593-7335

JEFFREY I. LEE, P.S.

## M & B INVESTMENTS 0.414 ACRE

Lying in Section 35, Town 4, Range 14, City of Bellefontaine, Lake Township, Logan County, Ohio.

Being out of the M & B Investments 1.114 acre tract as deeded and described in Official Record 108, Page 284 of the Logan County Records of Deeds and being more particularly described as follows:

Beginning at a 1/2 inch iron rod found at the intersection of the north line of Sandusky Avenue (70 feet wide) and the west line of Everett Street (40 feet wide). The said 1/2 inch iron rod is at the southeast corner of the 1.114 acre tract.

THENCE, with the north line of Sandusky Avenue, N 76°-47'-45" W, a distance of 89.42 feet to a 1/2 inch iron rod found at the southwest corner of the said 1.114 acre tract.

THENCE, with the lines of city lots 732 and 404 the following three courses:  
N 47°-17'-00" W, a distance of 167.18 feet to a 5/8 inch iron rod found  
S 42°-37'-03" W, a distance of 20.00 feet to a 5/8 inch iron rod found.  
N 47°-10'-43" W, a distance of 125.10 feet to a 5/8 inch iron rod set.

THENCE, N 17°-11'-59" E, a distance of 70.72 feet to a 5/8 inch iron rod set.

THENCE, with the south lines of the Lyn U. Hemmelgarn 0.148 acre tract (O.R. 66, Pg. 3) and the Margaret Ann Carey 0.24 and 0.25 acre tracts (O.R. 230, Pg. 248), S 47°-17'-00" E, a distance of 400.52 feet to the point of beginning.

Containing 0.414 acre.

The basis for bearings is based upon the northerly line of the M & B investments 1.114 acre tract being S 47°-17'-00" E, and all other bearings are from angles and distances measured in a field survey by Lee Surveying and Mapping Company on November 8, 1994.

Description prepared by:

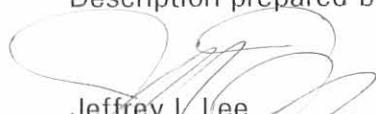
  
Jeffrey I. Lee  
Professional Surveyor 6359  
November 14, 1994



L 1693

ORIGINAL STAMP IN GREEN

INDEXED ON MAP  
6216 5D

LEGEND

- 1/2" IRON ROD FOUND
- 5/8" IRON ROD FOUND
- 1" METAL PIPE FOUND
- ⊗ PK NAIL FOUND
- ⊙ 1" IRON ROD FOUND IN MONUMENT BOX
- 5/8" IRON ROD SET

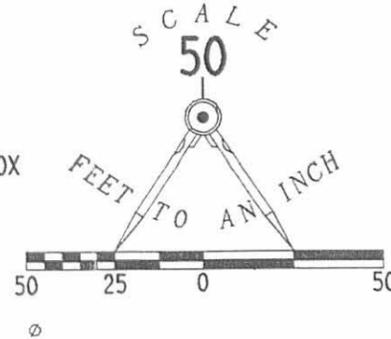

SURVEY OF 0.148 ACRE IN THE NAME OF  
 LYN U. HEMMELGARN AND MARY M. HEMMELGARN  
 OFFICIAL RECORD 66, PAGE 3  
 AND 0.414 ACRE OUT OF THE  
 M & B INVESTMENTS 1.114 ACRE TRACT  
 OFFICIAL RECORD 108, PAGE 284  
 SECTION 35, TOWN 4, RANGE 14 B.M.S.  
 CITY OF BELLEFONTAINE  
 LAKE TOWNSHIP, LOGAN COUNTY, OHIO

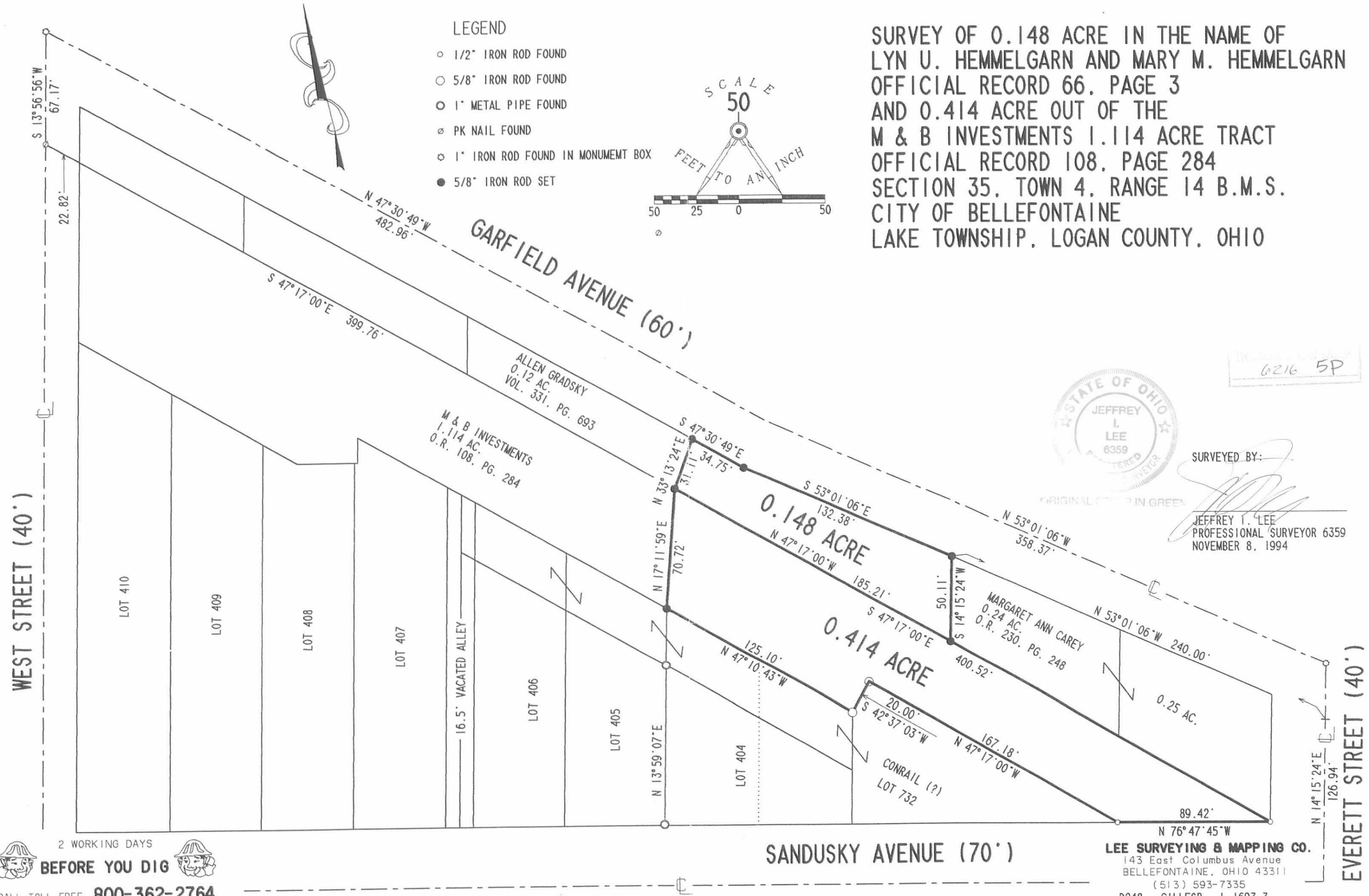

6216 5P



SURVEYED BY:  
 JEFFREY I. LEE  
 PROFESSIONAL SURVEYOR 6359  
 NOVEMBER 8, 1994

2 WORKING DAYS  
**BEFORE YOU DIG**  
 CALL TOLL FREE **800-362-2764**  
 OHIO UTILITIES PROTECTION SERVICE.

SANDUSKY AVENUE (70')

**LEE SURVEYING & MAPPING CO.**  
 143 East Columbus Avenue  
 BELLEFONTAINE, OHIO 43311  
 (513) 593-7335  
 D248 GILLESPIE L 1693-3

REC'D 5-21-04 OF JLB

# Lee Surveying and Mapping Co., Inc.

Land Surveys • Topography • Subdivisions • Construction Layout

117 N. Madriver St.  
Bellefontaine OH 43311

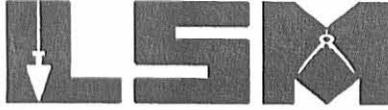

Phone: (937) 593-7335  
Fax: (937) 593-7444

## BELLEFONTAINE ENTERPRISES, LTD. 0.339 ACRE

Lying in Section 35, Town 4, Range 14, City of Bellefontaine, Lake Township, Logan County, Ohio.

Being out of the Bellefontaine Enterprises, Ltd. 0.854 acre tract as deeded and described in Official Record 677, Page 849 of the Logan County Records of Deeds and being more particularly described as follows:

Beginning at a MAG nail set at the intersection of the east right-of-way of Everett Street (40 feet wide) and the south right-of-way of Sandusky Avenue (70 feet wide).

THENCE, with the south right-of-way of Sandusky Avenue, S 76°-47'-45" E, a distance of 73.00 feet to a 5/8 inch iron rod found.

THENCE, with the lines of the Logan County Metropolitan Housing Authority 0.115 acre tract (O.R. 704, Pg. 914), the following two (2) courses:

S 47°-17'-00" E, a distance of 142.63 feet to a 5/8 inch iron rod found;

N 38°-59'-00" E, a distance of 22.80 feet to a 5/8 inch iron rod found.

THENCE, with the south line of the Logan County Metropolitan Housing Authority 0.167 acre tract (O.R. 561, Pg. 319), S 49°-38'-20" E, a distance of 111.00 feet to a 5/8 inch iron rod found at the TRUE POINT OF BEGINNING.

THENCE, with the south lines of the Clara Brown 0.191 acre tract (Vol. 351, Pg. 287) and the Clara Brown 0.05 acre tract (Vol. 372, Pg. 754, Tr II), S 49°-38'-20" E, a distance of 126.24 feet to a 2 inch iron bar found.

THENCE, with the west line and west line extended of the Clara Brown 0.06 acre tract (Vol. 373, Pg. 942), S 35°-14'-45" W, a distance of 118.22 feet to a 5/8 inch iron rod set.

THENCE, with the north lines of the Frank M. Slemmons 0.21 acre tract (O.R. 195, Pg. 212, Tract I) and the George E. Staley 0.39 acre tract and original 0.42 acre tract (O.R. 356, Pg. 326, Parcels I and II), N 49°-13'-50" W, a distance of 125.36 feet to a 5/8 inch iron rod found.

THENCE, with the east line of the Logan County Metropolitan Housing Authority 0.684 acre tract (O.R. 555, Pg. 98), N 34°-46'-40" E, a distance of 117.41 feet to the point of beginning.

Containing 0.339 acre.

The basis for bearings is the south right-of-way of Sandusky Avenue, being S 76°-47'-45" E, and all other bearings are from angles and distances measured in a field survey by Lee Surveying and Mapping Co., Inc. on May 18, 2004.

Description prepared by:



ORIGINAL STAMP IN GREEN

*Jeffrey I. Lee*  
Jeffrey I. Lee  
Professional Surveyor 6359  
May 18, 2004

L-1514

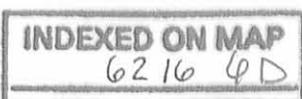

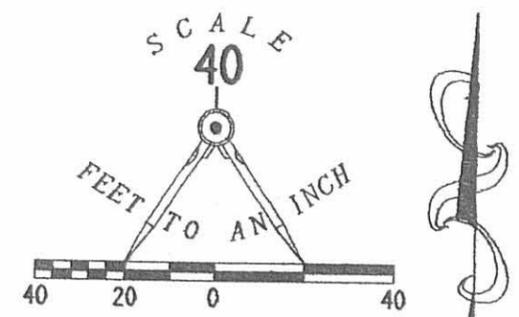
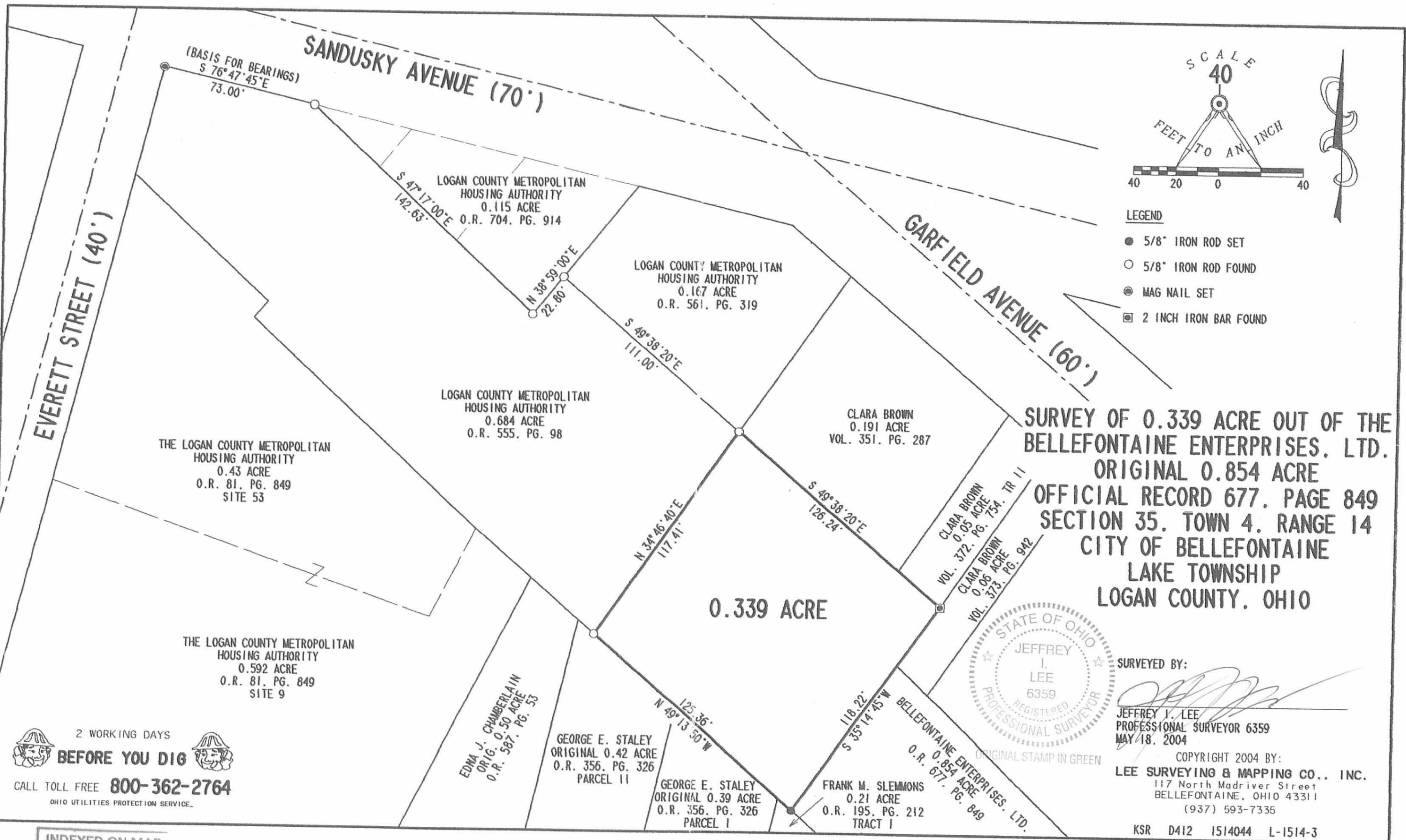

- LEGEND**
- 5/8" IRON ROD SET
  - 5/8" IRON ROD FOUND
  - ⊙ MAG NAIL SET
  - ⊠ 2 INCH IRON BAR FOUND

**SURVEY OF 0.339 ACRE OUT OF THE BELLEFONTAINE ENTERPRISES, LTD. ORIGINAL 0.854 ACRE OFFICIAL RECORD 677, PAGE 849 SECTION 35, TOWN 4, RANGE 14 CITY OF BELLEFONTAINE LAKE TOWNSHIP LOGAN COUNTY, OHIO**

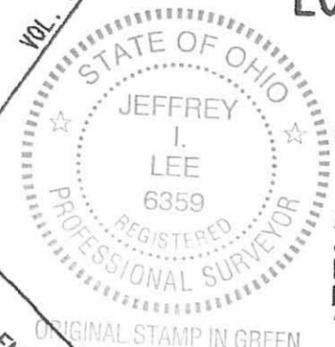

**SURVEYED BY:**  
*Jeffrey I. Lee*  
JEFFREY I. LEE  
PROFESSIONAL SURVEYOR 6359  
MAY 18, 2004

COPYRIGHT 2004 BY:  
**LEE SURVEYING & MAPPING CO., INC.**  
117 North Madriver Street  
BELLEFONTAINE, OHIO 43311  
(937) 593-7335

2 WORKING DAYS  
**BEFORE YOU DIG**  
CALL TOLL FREE **800-362-2764**  
OHIO UTILITIES PROTECTION SERVICE

INDEXED ON MAP  
6216 UP

KSR D412 1514044 L-1514-3

Case Number 88372

SCHEDULE "A"

*Township of Lake*

ALL THAT PARCEL of land situate in the City of Bellefontaine, County of Logan, State of Ohio, being part of Section 35, Township 4, Range 14, B.T.M.R.S., and being that property of the former Cleveland, Cincinnati, Chicago & St. Louis Railway Company (predecessor of said Grantor) further bounded and described according to a plan of survey made by The Jennings-Lawrence Company, Roy T. Underwood, Registered Surveyor No. 4084, dated November 1976, as follows:

BEGINNING at an iron pin at the northeasterly corner of McCracken's Revised Addition (recorded in Plat Book A, Volume 1, Page 24, Recorder's Office, Logan County, Ohio), said point being the intersection of the easterly line of said Addition with the northerly line of Charles Avenue (50 feet); thence North  $4^{\circ}05'24''$  East along the line between said Section 35 and Section 5, Township 3, Range 14, a distance of 918.28 feet to a stone at the common corner of said Sections; thence South  $85^{\circ}31'55''$  East along the northerly line of said Section 35 and the Corporation Line of the City of Bellefontaine, 678.55 feet to a concrete post; thence South  $37^{\circ}47'30''$  West parallel to and 85.46 feet therefrom, measured at right angles to Track No. 109, a distance of 1,223.11 feet to an iron pin in the easterly line of the previously mentioned Addition, said easterly line also being the easterly line of a 16 foot alley; thence North  $4^{\circ}09'30''$  East along the easterly line of said alley and of said Addition, 103.75 feet to the place of beginning.

CONTAINING 7.96 Acres, more or less.

INDEXED ON MAP  
6216 TD

WISH & GROVES INC.  
2 - 23 - 62  
59.22 Ac.

CONC. POST  
CORPORATION LINE  
678.55'  
5 85° 31' 55" E

7.959 Ac.

JOHN J. ZIESSLER ET AL.  
6 - 6 - 73  
13.82 Ac.

Section Corner  
36 35  
6 Stone 5

SEC. 35, TWP. 4, R. - 14  
SEC. 5, TWP. 3, R. - 14  
N04°09'30"E  
103.75'

SEC. 35, TWP. 4, R. - 14  
SEC. 5, TWP. 3, R. - 14

Mc CRACKEN'S REVISED A.D.D.

EUCLID STREET

MYRTLE AVE. 50'

FLORENCE AVE. 60'

CLAY AVE. 50'

COOK AVE. 50'

LAWRENCE ST. 45'

JAY STREET 45'

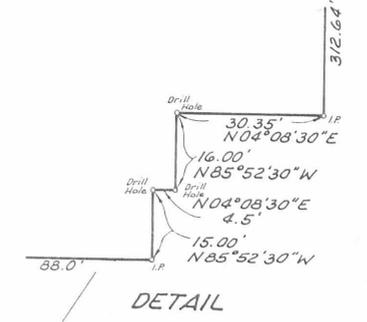
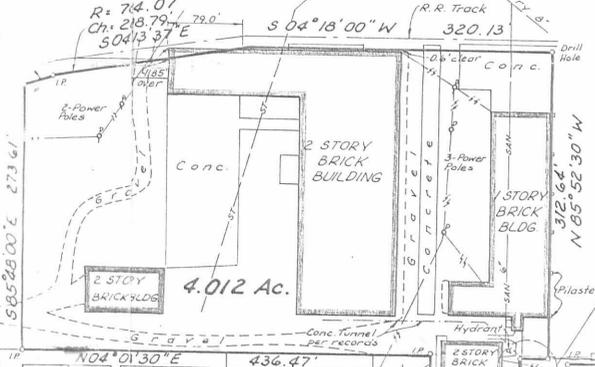

PART OF SEC. 5, TWP. 3, R. - 14 AND PART OF SEC. 35, TWP. 4, R. - 14,  
BETWEEN THE MIAMIS SURVEYS  
McCRACKEN'S AND COOK'S ADDITION, INCLUDED IN SECTION 5  
CITY OF BELLEFONTAINE,  
LOGAN COUNTY, OHIO

FOR

CLEVELAND, CINCINNATI, CHICAGO & ST. LOUIS RAILWAY COMPANY

SCALE: 1" = 100'

NOVEMBER, 1976

This survey certified as to correctness to the Cleveland, Cincinnati, Chicago & St. Louis Railway Company and the title insurance company insuring their interests in the premises.

THE JENNINGS - LAWRENCE CO.  
CIVIL - ENVIRONMENTAL - MUNICIPAL  
ENGINEERS & SURVEYORS  
COLUMBUS, OHIO

BY: *Ray F. Underwood*  
Registered Surveyor No. 3283, Ohio

McCracken's Revised Addition P.B.A - Vol. 1 - Pg. 24  
McCracken's & Cook's Addition P.B.A - Vol. 1 - Pg. 36  
Hawenstine's 2nd Addition P.B.A - Vol. 1 - Pg. 30

Alleys and Part of Cook Avenue within 1.762 Acre Tract vacated by Ordinance No. 1692, June 8, 1942.

Alley within 4.012 Acre Tract vacated per Ordinance Book 1, Pgs. 293-302, March 8, 1900.

Underground Utility Information is from R.R. Records.

INDEXED ON MAP  
6216

INDEXED ON MAP  
6216 7P

47



N.Y.C.R.R.-OHIO CENTRAL LINES  
 STATION PLAN OF  
**BELLEFONTAINE**  
 SCALE 1"=100' DATE 10-20-26  
 OFFICE OF DIVISION ENGINEER  
 COLUMBUS O  
 PLAN No 532.



Situate in the County of Logan, State of Ohio, and being part of The Cleveland, Cincinnati, Chicago and St. Louis Railway Company's line of railroad which is known as the Penn Central Bellefontaine Running Track and is described in Exhibit A of this Deed, and being all of the real property in the County lying in, under, above, along, contiguous to and adjacent to that part of the line of railroad which lies beyond and initially northerly of the following described lateral cut line:

Being the northerly abutment of Bridge No. 211, which intersects the centerline of railroad right-of-way at Station 53+06, more or less, as shown on Railroad Valuation Map No. 072-5420-0-24-7 as revised to February 28, 1967.

The part of the line of railroad described herein begins at the lateral cut line in McArthur and extends to the end of the line near Belle Center in Richland.

The lateral cut line is identified as Line Code 8147-94.0 in the records of the United States Railway Association.

Avs. R.O.W. = 23.62 AC. THIS SHT. 116.49 TOTAL

CCC+STL-CRC-RP-77  
REVISED 9/11/78 RLH

8147-93.2

OWNER 072 VALUATION SUB SECTION DIV. NUMBER SHEET REAL ESTATE REGION  
5420 0 24 7

LC 8147 (17)

CCC+STL-CRC-RP77

RSA

ADDED

| Item | Acres | Assessment | Year |
|------|-------|------------|------|
| 1    | 1.00  | 100.00     | 1978 |
| 2    | 1.00  | 100.00     | 1978 |
| 3    | 1.00  | 100.00     | 1978 |
| 4    | 1.00  | 100.00     | 1978 |
| 5    | 1.00  | 100.00     | 1978 |
| 6    | 1.00  | 100.00     | 1978 |
| 7    | 1.00  | 100.00     | 1978 |
| 8    | 1.00  | 100.00     | 1978 |
| 9    | 1.00  | 100.00     | 1978 |
| 10   | 1.00  | 100.00     | 1978 |
| 11   | 1.00  | 100.00     | 1978 |
| 12   | 1.00  | 100.00     | 1978 |
| 13   | 1.00  | 100.00     | 1978 |
| 14   | 1.00  | 100.00     | 1978 |
| 15   | 1.00  | 100.00     | 1978 |
| 16   | 1.00  | 100.00     | 1978 |
| 17   | 1.00  | 100.00     | 1978 |
| 18   | 1.00  | 100.00     | 1978 |
| 19   | 1.00  | 100.00     | 1978 |
| 20   | 1.00  | 100.00     | 1978 |
| 21   | 1.00  | 100.00     | 1978 |
| 22   | 1.00  | 100.00     | 1978 |
| 23   | 1.00  | 100.00     | 1978 |
| 24   | 1.00  | 100.00     | 1978 |
| 25   | 1.00  | 100.00     | 1978 |
| 26   | 1.00  | 100.00     | 1978 |
| 27   | 1.00  | 100.00     | 1978 |
| 28   | 1.00  | 100.00     | 1978 |
| 29   | 1.00  | 100.00     | 1978 |
| 30   | 1.00  | 100.00     | 1978 |
| 31   | 1.00  | 100.00     | 1978 |
| 32   | 1.00  | 100.00     | 1978 |
| 33   | 1.00  | 100.00     | 1978 |
| 34   | 1.00  | 100.00     | 1978 |
| 35   | 1.00  | 100.00     | 1978 |
| 36   | 1.00  | 100.00     | 1978 |
| 37   | 1.00  | 100.00     | 1978 |
| 38   | 1.00  | 100.00     | 1978 |
| 39   | 1.00  | 100.00     | 1978 |
| 40   | 1.00  | 100.00     | 1978 |
| 41   | 1.00  | 100.00     | 1978 |
| 42   | 1.00  | 100.00     | 1978 |
| 43   | 1.00  | 100.00     | 1978 |
| 44   | 1.00  | 100.00     | 1978 |
| 45   | 1.00  | 100.00     | 1978 |
| 46   | 1.00  | 100.00     | 1978 |
| 47   | 1.00  | 100.00     | 1978 |
| 48   | 1.00  | 100.00     | 1978 |
| 49   | 1.00  | 100.00     | 1978 |
| 50   | 1.00  | 100.00     | 1978 |
| 51   | 1.00  | 100.00     | 1978 |
| 52   | 1.00  | 100.00     | 1978 |
| 53   | 1.00  | 100.00     | 1978 |
| 54   | 1.00  | 100.00     | 1978 |
| 55   | 1.00  | 100.00     | 1978 |
| 56   | 1.00  | 100.00     | 1978 |
| 57   | 1.00  | 100.00     | 1978 |
| 58   | 1.00  | 100.00     | 1978 |
| 59   | 1.00  | 100.00     | 1978 |
| 60   | 1.00  | 100.00     | 1978 |
| 61   | 1.00  | 100.00     | 1978 |
| 62   | 1.00  | 100.00     | 1978 |
| 63   | 1.00  | 100.00     | 1978 |
| 64   | 1.00  | 100.00     | 1978 |
| 65   | 1.00  | 100.00     | 1978 |
| 66   | 1.00  | 100.00     | 1978 |
| 67   | 1.00  | 100.00     | 1978 |
| 68   | 1.00  | 100.00     | 1978 |
| 69   | 1.00  | 100.00     | 1978 |
| 70   | 1.00  | 100.00     | 1978 |
| 71   | 1.00  | 100.00     | 1978 |
| 72   | 1.00  | 100.00     | 1978 |
| 73   | 1.00  | 100.00     | 1978 |
| 74   | 1.00  | 100.00     | 1978 |
| 75   | 1.00  | 100.00     | 1978 |
| 76   | 1.00  | 100.00     | 1978 |
| 77   | 1.00  | 100.00     | 1978 |
| 78   | 1.00  | 100.00     | 1978 |
| 79   | 1.00  | 100.00     | 1978 |
| 80   | 1.00  | 100.00     | 1978 |
| 81   | 1.00  | 100.00     | 1978 |
| 82   | 1.00  | 100.00     | 1978 |
| 83   | 1.00  | 100.00     | 1978 |
| 84   | 1.00  | 100.00     | 1978 |
| 85   | 1.00  | 100.00     | 1978 |
| 86   | 1.00  | 100.00     | 1978 |
| 87   | 1.00  | 100.00     | 1978 |
| 88   | 1.00  | 100.00     | 1978 |
| 89   | 1.00  | 100.00     | 1978 |
| 90   | 1.00  | 100.00     | 1978 |
| 91   | 1.00  | 100.00     | 1978 |
| 92   | 1.00  | 100.00     | 1978 |
| 93   | 1.00  | 100.00     | 1978 |
| 94   | 1.00  | 100.00     | 1978 |
| 95   | 1.00  | 100.00     | 1978 |
| 96   | 1.00  | 100.00     | 1978 |
| 97   | 1.00  | 100.00     | 1978 |
| 98   | 1.00  | 100.00     | 1978 |
| 99   | 1.00  | 100.00     | 1978 |
| 100  | 1.00  | 100.00     | 1978 |

MS 10306  
MS 10307

CROSSING NO. 92.73-SD  
CROSSING NO. 93.18-SD  
ESTATE CRC

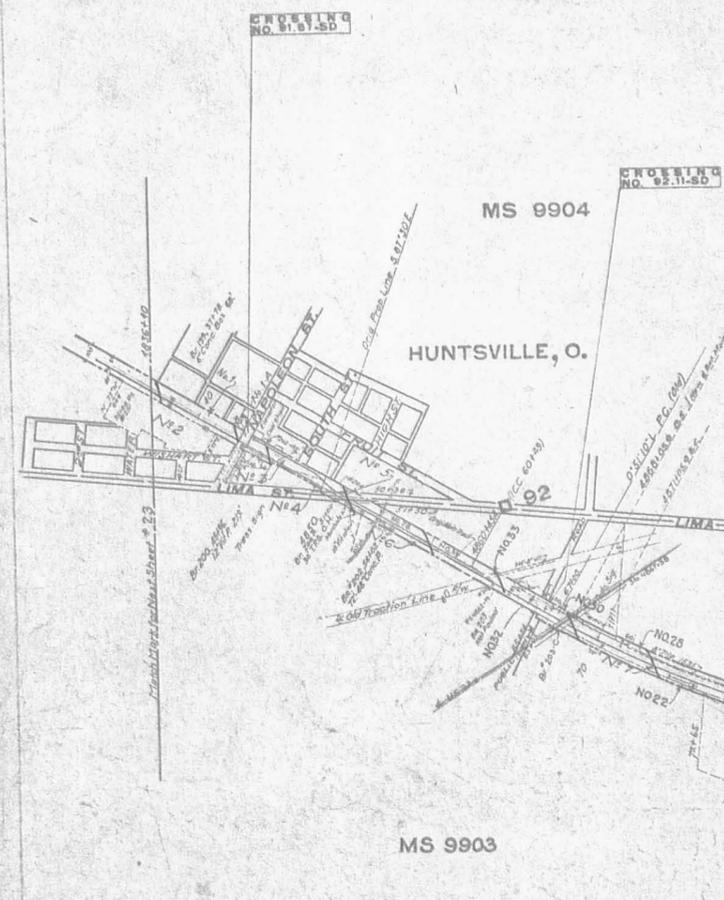

HUNTVILLE, O.

MS 9903

MCARTHUR TWP.  
HARRISON TWP.

GREENVILLE TREATY LINE

LOGAN CO. OHIO

SE BRV LINE OF  
TWP. RD. # 220  
STA. 23+46  
C-OH. D000M79

MS 9881

| NUMBER | GRANTOR                   | GRANTEE       | INSTRUMENT | DATE    | RECORD  | CUSTODIAN NUMBER | V42-92        |
|--------|---------------------------|---------------|------------|---------|---------|------------------|---------------|
| 15     | J.L. McCormick et al      | C.S. & C.R.R. | WD         | 7-15-77 | 152/327 | 163              | Legen Co Ohio |
| 16     | John A. Blair et al       | ..            | ..         | 8-15-77 | 152/315 | 164              | ..            |
| 17     | Neil H. Hoots             | ..            | ..         | 8-15-77 | 152/315 | 165              | ..            |
| 18     | R.R. Gregg et al          | ..            | ..         | 8-24-77 | 152/311 | 166              | ..            |
| 19     | F.L. Johnson et al        | ..            | ..         | 6-15-77 | 152/345 | 167              | ..            |
| 20     | Morgan T. Frederick et al | ..            | ..         | 6-11-77 | 152/345 | 168              | ..            |
| 21     | Dennis M. Johnson         | ..            | ..         | 6-15-77 | 152/354 | 169              | ..            |
| 22     | Wm. Waples et al          | ..            | ..         | 6-15-77 | 152/354 | 170              | ..            |
| 23     | W.H. Angeline et al       | ..            | ..         | 6-15-77 | 152/354 | 171              | ..            |
| 24     | Chas. H. Buckwalter et al | ..            | ..         | 7-1-77  | 152/354 | 172              | ..            |
| 25     | F.C. Coats et al          | ..            | ..         | 7-15-77 | 152/358 | 175              | ..            |
| 26     | David Shultz et al        | ..            | ..         | 7-15-77 | 152/357 | 181              | ..            |
| 27     | Cervie E. McCormick et al | ..            | ..         | 7-6-77  | 152/349 | 178              | ..            |
| 28     | K.C. Montgomery et al     | ..            | ..         | 9-1-77  | 152/399 | 179              | ..            |
| 29     | Ela. E. Wilson            | ..            | ..         | 9-1-77  | 152/360 | 180              | ..            |
| 30     | Mark H. Stokes et al      | ..            | ..         | 8-10-77 | 152/345 | 192              | ..            |
| 31     | E.S. Boyer et al          | ..            | ..         | 11-3-77 | 152/328 | 183              | ..            |
| 32     | Edna and Andrew Hoest     | ..            | ..         | 11-3-77 | 152/358 | 193              | ..            |
| 33     | Leonia M. Peterson et al  | ..            | ..         | 4-27-78 | 157/265 | 201              | ..            |
| 34     | John A. Jones             | ..            | ..         | 8-4-78  | 189/442 | 201              | ..            |

072-5420-0-24-7  
LC 8147-93.2

| NUMBER | GRANTOR          | GRANTEE | INSTRUMENT | DATE    | RECORD   | CUSTODIAN NUMBER | V42-92 |
|--------|------------------|---------|------------|---------|----------|------------------|--------|
| 1      | Thos. W. Hart    | ..      | ..         | 7/23/45 | 55/2065  | 42               | ..     |
| 2      | John C. Hart     | ..      | ..         | 7/23/45 | 55/2099  | 43               | ..     |
| 3      | James Cassel     | ..      | ..         | 7/23/45 | 55/2132  | 47               | ..     |
| 4      | Franklin A. Reed | ..      | ..         | 7/23/45 | 55/2111  | 46               | ..     |
| 5      | W. T. Hart       | ..      | ..         | 7/23/45 | 55/2177  | 54               | ..     |
| 6      | James A. Ireland | ..      | ..         | 7/23/45 | 114/2000 | 57               | ..     |
| 7      | David J. Ireland | ..      | ..         | 7/23/45 | 114/2000 | 58               | ..     |
| 8      | David J. Ireland | ..      | ..         | 7/23/45 | 55/2048  | 564              | ..     |
| 9      | James A. Ireland | ..      | ..         | 7/23/45 | 55/2048  | 565              | ..     |
| 10     | W. T. Hart       | ..      | ..         | 7/23/45 | 55/2048  | 566              | ..     |
| 11     | James A. Ireland | ..      | ..         | 7/23/45 | 55/2048  | 567              | ..     |
| 12     | James A. Ireland | ..      | ..         | 7/23/45 | 55/2048  | 568              | ..     |
| 13     | John A. Jones    | ..      | ..         | 7/23/45 | 55/2048  | 569              | ..     |
| 14     | John A. Jones    | ..      | ..         | 7/23/45 | 55/2048  | 570              | ..     |
| 15     | John A. Jones    | ..      | ..         | 7/23/45 | 55/2048  | 571              | ..     |
| 16     | John A. Jones    | ..      | ..         | 7/23/45 | 55/2048  | 572              | ..     |
| 17     | John A. Jones    | ..      | ..         | 7/23/45 | 55/2048  | 573              | ..     |
| 18     | John A. Jones    | ..      | ..         | 7/23/45 | 55/2048  | 574              | ..     |
| 19     | John A. Jones    | ..      | ..         | 7/23/45 | 55/2048  | 575              | ..     |
| 20     | John A. Jones    | ..      | ..         | 7/23/45 | 55/2048  | 576              | ..     |
| 21     | John A. Jones    | ..      | ..         | 7/23/45 | 55/2048  | 577              | ..     |
| 22     | John A. Jones    | ..      | ..         | 7/23/45 | 55/2048  | 578              | ..     |
| 23     | John A. Jones    | ..      | ..         | 7/23/45 | 55/2048  | 579              | ..     |
| 24     | John A. Jones    | ..      | ..         | 7/23/45 | 55/2048  | 580              | ..     |
| 25     | John A. Jones    | ..      | ..         | 7/23/45 | 55/2048  | 581              | ..     |
| 26     | John A. Jones    | ..      | ..         | 7/23/45 | 55/2048  | 582              | ..     |
| 27     | John A. Jones    | ..      | ..         | 7/23/45 | 55/2048  | 583              | ..     |
| 28     | John A. Jones    | ..      | ..         | 7/23/45 | 55/2048  | 584              | ..     |
| 29     | John A. Jones    | ..      | ..         | 7/23/45 | 55/2048  | 585              | ..     |
| 30     | John A. Jones    | ..      | ..         | 7/23/45 | 55/2048  | 586              | ..     |
| 31     | John A. Jones    | ..      | ..         | 7/23/45 | 55/2048  | 587              | ..     |
| 32     | John A. Jones    | ..      | ..         | 7/23/45 | 55/2048  | 588              | ..     |
| 33     | John A. Jones    | ..      | ..         | 7/23/45 | 55/2048  | 589              | ..     |
| 34     | John A. Jones    | ..      | ..         | 7/23/45 | 55/2048  | 590              | ..     |
| 35     | John A. Jones    | ..      | ..         | 7/23/45 | 55/2048  | 591              | ..     |
| 36     | John A. Jones    | ..      | ..         | 7/23/45 | 55/2048  | 592              | ..     |
| 37     | John A. Jones    | ..      | ..         | 7/23/45 | 55/2048  | 593              | ..     |
| 38     | John A. Jones    | ..      | ..         | 7/23/45 | 55/2048  | 594              | ..     |
| 39     | John A. Jones    | ..      | ..         | 7/23/45 | 55/2048  | 595              | ..     |
| 40     | John A. Jones    | ..      | ..         | 7/23/45 | 55/2048  | 596              | ..     |
| 41     | John A. Jones    | ..      | ..         | 7/23/45 | 55/2048  | 597              | ..     |
| 42     | John A. Jones    | ..      | ..         | 7/23/45 | 55/2048  | 598              | ..     |
| 43     | John A. Jones    | ..      | ..         | 7/23/45 | 55/2048  | 599              | ..     |
| 44     | John A. Jones    | ..      | ..         | 7/23/45 | 55/2048  | 600              | ..     |

MAP CORRECTIONS  
1951 No Change  
1952 No Change  
1953 12-16-55  
1954 10-11-57  
1955 10-25-58  
1956 No Change  
1957 u.v.  
1958 9-1-60  
1959 10-1-60  
1960 2-18-67

CORRECTED TO DEC. 31, 1968  
CORRECTED TO DECEMBER 31, 1969  
CORRECTED TO DECEMBER 31, 1970  
CORRECTED TO DECEMBER 31, 1971  
CORRECTED TO DECEMBER 31, 1972  
CORRECTED TO DECEMBER 31, 1973  
CORRECTED TO DECEMBER 31, 1974  
CORRECTED TO DECEMBER 31, 1975  
CORRECTED TO DECEMBER 31, 1976  
CORRECTED TO DECEMBER 31, 1977  
CORRECTED TO DECEMBER 31, 1978  
CORRECTED TO DECEMBER 31, 1979  
CORRECTED TO DECEMBER 31, 1980  
CORRECTED TO DECEMBER 31, 1981  
CORRECTED TO DECEMBER 31, 1982  
CORRECTED TO DECEMBER 31, 1983  
CORRECTED TO DECEMBER 31, 1984  
CORRECTED TO DECEMBER 31, 1985  
CORRECTED TO DECEMBER 31, 1986  
CORRECTED TO DECEMBER 31, 1987  
CORRECTED TO DECEMBER 31, 1988  
CORRECTED TO DECEMBER 31, 1989  
CORRECTED TO DECEMBER 31, 1990  
CORRECTED TO DECEMBER 31, 1991  
CORRECTED TO DECEMBER 31, 1992  
CORRECTED TO DECEMBER 31, 1993  
CORRECTED TO DECEMBER 31, 1994  
CORRECTED TO DECEMBER 31, 1995  
CORRECTED TO DECEMBER 31, 1996  
CORRECTED TO DECEMBER 31, 1997  
CORRECTED TO DECEMBER 31, 1998  
CORRECTED TO DECEMBER 31, 1999  
CORRECTED TO DECEMBER 31, 2000  
CORRECTED TO DECEMBER 31, 2001  
CORRECTED TO DECEMBER 31, 2002  
CORRECTED TO DECEMBER 31, 2003  
CORRECTED TO DECEMBER 31, 2004  
CORRECTED TO DECEMBER 31, 2005  
CORRECTED TO DECEMBER 31, 2006  
CORRECTED TO DECEMBER 31, 2007  
CORRECTED TO DECEMBER 31, 2008  
CORRECTED TO DECEMBER 31, 2009  
CORRECTED TO DECEMBER 31, 2010  
CORRECTED TO DECEMBER 31, 2011  
CORRECTED TO DECEMBER 31, 2012  
CORRECTED TO DECEMBER 31, 2013  
CORRECTED TO DECEMBER 31, 2014  
CORRECTED TO DECEMBER 31, 2015  
CORRECTED TO DECEMBER 31, 2016  
CORRECTED TO DECEMBER 31, 2017  
CORRECTED TO DECEMBER 31, 2018  
CORRECTED TO DECEMBER 31, 2019  
CORRECTED TO DECEMBER 31, 2020  
CORRECTED TO DECEMBER 31, 2021  
CORRECTED TO DECEMBER 31, 2022  
CORRECTED TO DECEMBER 31, 2023  
CORRECTED TO DECEMBER 31, 2024  
CORRECTED TO DECEMBER 31, 2025  
CORRECTED TO DECEMBER 31, 2026  
CORRECTED TO DECEMBER 31, 2027  
CORRECTED TO DECEMBER 31, 2028  
CORRECTED TO DECEMBER 31, 2029  
CORRECTED TO DECEMBER 31, 2030

THIS TRACING IS 50% ORIGINAL SIZE  
DRAWN TO DOUBLE SCALE

INDEXED ON MAP  
0214 11P

All that parcel of land located at Bellefontaine and situate in the Township of Lake, County of Logan, and State of Ohio, being part of Section 35 of Township 4, Range 14, M.R.S., being designated as Parcel No. OH D090 08-7 on Railroad Valuation Map No. 500-3030-0-11-7, as revised to July 28, 1958 and being all the land of the Penn Central Transportation Company, as shown on the Map, which lies southwesterly, southeasterly, and southwesterly of the following described lines:

Beginning on the northerly line of Sandusky (Center) Street at a point therein distant 15 feet southwestwardly at right angles from the centerline of near track of railroad of The Cleveland, Cincinnati, Chicago and St. Louis Railway Company, as it was located on January 7, 1976;

Thence, northwestwardly parallel to said centerline of track 190 feet, to a point;

Thence, southwardly 20 feet, more or less, to a point distant 35 feet southwestwardly at right angles from said centerline of near track;

Thence, northwestwardly, parallel to said centerline of track 250 feet, more or less, to a point on the easterly line of an alley, the point of ending.

The above described parcel or parcels are identified in the records of the United States Railway Association as Line Code 8147-98.

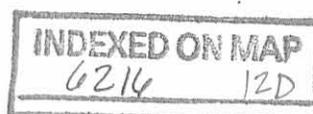

15 days for Vol. B

8147-98

LOGAN COUNTY  
LAKE TOWNSHIP

|         |             |           |             |
|---------|-------------|-----------|-------------|
| OWNER   | VALUATION   | SUB SHEET | REAL ESTATE |
| 500     | 3030        | 11        | 17          |
| SECTION | DIV. NUMBER |           | REGION      |

THIS TRACING IS 50% ORIGINAL SIZE.  
DRAFTSMAN TO DOUBLE SCALE

RSK

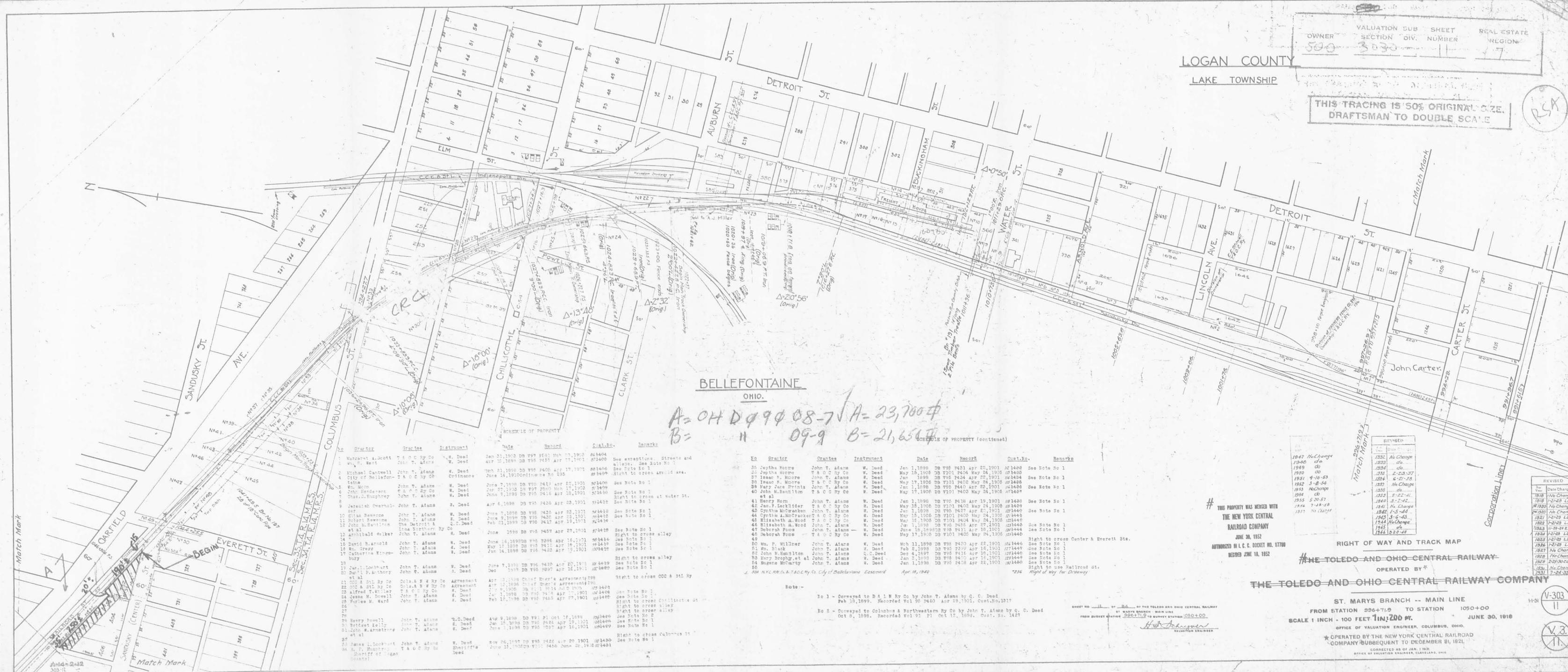

BELLEFONTAINE  
OHIO.  
A=23,700  
B=21,650

SCHEDULE OF PROPERTY (continued)

| No. | Grantor               | Grantee       | Instrument   | Date          | Record           | Cont. No.    | Remarks  |        |
|-----|-----------------------|---------------|--------------|---------------|------------------|--------------|--|--------|
| 1   | Marshall Abbott       | T & O Ry Co   | W. Deed      | Jan 22, 1903  | DB 797           | 181          | See exceptions. Streets and alleys. See Note No 1. |        |
| 2   | John T. Adams         | W. Deed       | Apr 12, 1898 | DB 795        | 1457             | Apr 17, 1901 | 263406   |        |
| 3   | Michael Cartwell      | John T. Adams | W. Deed      | June 21, 1898 | DB 795           | 1458         | Apr 17, 1901                                       | 263406 |
| 4   | City of Bellefontaine | T & O Ry Co   | Ordinance    | June 14, 1910 | Ordinance No 295 |              | Right to cross at 14 ave.                          |        |
| 5   | John Handerson        | T & O Ry Co   | W. Deed      | June 7, 1898  | DB 795           | 1459         | See Note No 1.                                     |        |
| 6   | John Handerson        | T & O Ry Co   | W. Deed      | Apr 27, 1903  | DB 798           | 2500         | Mar 17, 1903                                       | 214498 |
| 7   | John Handerson        | T & O Ry Co   | W. Deed      | Apr 27, 1903  | DB 798           | 2501         | Mar 17, 1903                                       | 214498 |
| 8   | John Handerson        | T & O Ry Co   | W. Deed      | Apr 27, 1903  | DB 798           | 2502         | Mar 17, 1903                                       | 214498 |
| 9   | John Handerson        | T & O Ry Co   | W. Deed      | Apr 27, 1903  | DB 798           | 2503         | Mar 17, 1903                                       | 214498 |
| 10  | John Handerson        | T & O Ry Co   | W. Deed      | Apr 27, 1903  | DB 798           | 2504         | Mar 17, 1903                                       | 214498 |
| 11  | John Handerson        | T & O Ry Co   | W. Deed      | Apr 27, 1903  | DB 798           | 2505         | Mar 17, 1903                                       | 214498 |
| 12  | John Handerson        | T & O Ry Co   | W. Deed      | Apr 27, 1903  | DB 798           | 2506         | Mar 17, 1903                                       | 214498 |
| 13  | John Handerson        | T & O Ry Co   | W. Deed      | Apr 27, 1903  | DB 798           | 2507         | Mar 17, 1903                                       | 214498 |
| 14  | John Handerson        | T & O Ry Co   | W. Deed      | Apr 27, 1903  | DB 798           | 2508         | Mar 17, 1903                                       | 214498 |
| 15  | John Handerson        | T & O Ry Co   | W. Deed      | Apr 27, 1903  | DB 798           | 2509         | Mar 17, 1903                                       | 214498 |
| 16  | John Handerson        | T & O Ry Co   | W. Deed      | Apr 27, 1903  | DB 798           | 2510         | Mar 17, 1903                                       | 214498 |
| 17  | John Handerson        | T & O Ry Co   | W. Deed      | Apr 27, 1903  | DB 798           | 2511         | Mar 17, 1903                                       | 214498 |
| 18  | John Handerson        | T & O Ry Co   | W. Deed      | Apr 27, 1903  | DB 798           | 2512         | Mar 17, 1903                                       | 214498 |
| 19  | John Handerson        | T & O Ry Co   | W. Deed      | Apr 27, 1903  | DB 798           | 2513         | Mar 17, 1903                                       | 214498 |
| 20  | John Handerson        | T & O Ry Co   | W. Deed      | Apr 27, 1903  | DB 798           | 2514         | Mar 17, 1903                                       | 214498 |
| 21  | John Handerson        | T & O Ry Co   | W. Deed      | Apr 27, 1903  | DB 798           | 2515         | Mar 17, 1903                                       | 214498 |
| 22  | John Handerson        | T & O Ry Co   | W. Deed      | Apr 27, 1903  | DB 798           | 2516         | Mar 17, 1903                                       | 214498 |
| 23  | John Handerson        | T & O Ry Co   | W. Deed      | Apr 27, 1903  | DB 798           | 2517         | Mar 17, 1903                                       | 214498 |
| 24  | John Handerson        | T & O Ry Co   | W. Deed      | Apr 27, 1903  | DB 798           | 2518         | Mar 17, 1903                                       | 214498 |
| 25  | John Handerson        | T & O Ry Co   | W. Deed      | Apr 27, 1903  | DB 798           | 2519         | Mar 17, 1903                                       | 214498 |
| 26  | John Handerson        | T & O Ry Co   | W. Deed      | Apr 27, 1903  | DB 798           | 2520         | Mar 17, 1903                                       | 214498 |
| 27  | John Handerson        | T & O Ry Co   | W. Deed      | Apr 27, 1903  | DB 798           | 2521         | Mar 17, 1903                                       | 214498 |
| 28  | John Handerson        | T & O Ry Co   | W. Deed      | Apr 27, 1903  | DB 798           | 2522         | Mar 17, 1903                                       | 214498 |
| 29  | John Handerson        | T & O Ry Co   | W. Deed      | Apr 27, 1903  | DB 798           | 2523         | Mar 17, 1903                                       | 214498 |
| 30  | John Handerson        | T & O Ry Co   | W. Deed      | Apr 27, 1903  | DB 798           | 2524         | Mar 17, 1903                                       | 214498 |
| 31  | John Handerson        | T & O Ry Co   | W. Deed      | Apr 27, 1903  | DB 798           | 2525         | Mar 17, 1903                                       | 214498 |
| 32  | John Handerson        | T & O Ry Co   | W. Deed      | Apr 27, 1903  | DB 798           | 2526         | Mar 17, 1903                                       | 214498 |
| 33  | John Handerson        | T & O Ry Co   | W. Deed      | Apr 27, 1903  | DB 798           | 2527         | Mar 17, 1903                                       | 214498 |
| 34  | John Handerson        | T & O Ry Co   | W. Deed      | Apr 27, 1903  | DB 798           | 2528         | Mar 17, 1903                                       | 214498 |
| 35  | John Handerson        | T & O Ry Co   | W. Deed      | Apr 27, 1903  | DB 798           | 2529         | Mar 17, 1903                                       | 214498 |
| 36  | John Handerson        | T & O Ry Co   | W. Deed      | Apr 27, 1903  | DB 798           | 2530         | Mar 17, 1903                                       | 214498 |
| 37  | John Handerson        | T & O Ry Co   | W. Deed      | Apr 27, 1903  | DB 798           | 2531         | Mar 17, 1903                                       | 214498 |
| 38  | John Handerson        | T & O Ry Co   | W. Deed      | Apr 27, 1903  | DB 798           | 2532         | Mar 17, 1903                                       | 214498 |
| 39  | John Handerson        | T & O Ry Co   | W. Deed      | Apr 27, 1903  | DB 798           | 2533         | Mar 17, 1903                                       | 214498 |
| 40  | John Handerson        | T & O Ry Co   | W. Deed      | Apr 27, 1903  | DB 798           | 2534         | Mar 17, 1903                                       | 214498 |
| 41  | John Handerson        | T & O Ry Co   | W. Deed      | Apr 27, 1903  | DB 798           | 2535         | Mar 17, 1903                                       | 214498 |
| 42  | John Handerson        | T & O Ry Co   | W. Deed      | Apr 27, 1903  | DB 798           | 2536         | Mar 17, 1903                                       | 214498 |
| 43  | John Handerson        | T & O Ry Co   | W. Deed      | Apr 27, 1903  | DB 798           | 2537         | Mar 17, 1903                                       | 214498 |
| 44  | John Handerson        | T & O Ry Co   | W. Deed      | Apr 27, 1903  | DB 798           | 2538         | Mar 17, 1903                                       | 214498 |
| 45  | John Handerson        | T & O Ry Co   | W. Deed      | Apr 27, 1903  | DB 798           | 2539         | Mar 17, 1903                                       | 214498 |
| 46  | John Handerson        | T & O Ry Co   | W. Deed      | Apr 27, 1903  | DB 798           | 2540         | Mar 17, 1903                                       | 214498 |
| 47  | John Handerson        | T & O Ry Co   | W. Deed      | Apr 27, 1903  | DB 798           | 2541         | Mar 17, 1903                                       | 214498 |
| 48  | John Handerson        | T & O Ry Co   | W. Deed      | Apr 27, 1903  | DB 798           | 2542         | Mar 17, 1903                                       | 214498 |
| 49  | John Handerson        | T & O Ry Co   | W. Deed      | Apr 27, 1903  | DB 798           | 2543         | Mar 17, 1903                                       | 214498 |
| 50  | John Handerson        | T & O Ry Co   | W. Deed      | Apr 27, 1903  | DB 798           | 2544         | Mar 17, 1903                                       | 214498 |
| 51  | John Handerson        | T & O Ry Co   | W. Deed      | Apr 27, 1903  | DB 798           | 2545         | Mar 17, 1903                                       | 214498 |
| 52  | John Handerson        | T & O Ry Co   | W. Deed      | Apr 27, 1903  | DB 798           | 2546         | Mar 17, 1903                                       | 214498 |
| 53  | John Handerson        | T & O Ry Co   | W. Deed      | Apr 27, 1903  | DB 798           | 2547         | Mar 17, 1903                                       | 214498 |
| 54  | John Handerson        | T & O Ry Co   | W. Deed      | Apr 27, 1903  | DB 798           | 2548         | Mar 17, 1903                                       | 214498 |
| 55  | John Handerson        | T & O Ry Co   | W. Deed      | Apr 27, 1903  | DB 798           | 2549         | Mar 17, 1903                                       | 214498 |
| 56  | John Handerson        | T & O Ry Co   | W. Deed      | Apr 27, 1903  | DB 798           | 2550         | Mar 17, 1903                                       | 214498 |
| 57  | John Handerson        | T & O Ry Co   | W. Deed      | Apr 27, 1903  | DB 798           | 2551         | Mar 17, 1903                                       | 214498 |
| 58  | John Handerson        | T & O Ry Co   | W. Deed      | Apr 27, 1903  | DB 798           | 2552         | Mar 17, 1903                                       | 214498 |
| 59  | John Handerson        | T & O Ry Co   | W. Deed      | Apr 27, 1903  | DB 798           | 2553         | Mar 17, 1903                                       | 214498 |
| 60  | John Handerson        | T & O Ry Co   | W. Deed      | Apr 27, 1903  | DB 798           | 2554         | Mar 17, 1903                                       | 214498 |
| 61  | John Handerson        | T & O Ry Co   | W. Deed      | Apr 27, 1903  | DB 798           | 2555         | Mar 17, 1903                                       | 214498 |
| 62  | John Handerson        | T & O Ry Co   | W. Deed      | Apr 27, 1903  | DB 798           | 2556         | Mar 17, 1903                                       | 214498 |
| 63  | John Handerson        | T & O Ry Co   | W. Deed      | Apr 27, 1903  | DB 798           | 2557         | Mar 17, 1903                                       | 214498 |
| 64  | John Handerson        | T & O Ry Co   | W. Deed      | Apr 27, 1903  | DB 798           | 2558         | Mar 17, 1903                                       | 214498 |
| 65  | John Handerson        | T & O Ry Co   | W. Deed      | Apr 27, 1903  | DB 798           | 2559         | Mar 17, 1903                                       | 214498 |
| 66  | John Handerson        | T & O Ry Co   | W. Deed      | Apr 27, 1903  | DB 798           | 2560         | Mar 17, 1903                                       | 214498 |
| 67  | John Handerson        | T & O Ry Co   | W. Deed      | Apr 27, 1903  | DB 798           | 2561         | Mar 17, 1903                                       | 214498 |
| 68  | John Handerson        | T & O Ry Co   | W. Deed      | Apr 27, 1903  | DB 798           | 2562         | Mar 17, 1903                                       | 214498 |
| 69  | John Handerson        | T & O Ry Co   | W. Deed      | Apr 27, 1903  | DB 798           | 2563         | Mar 17, 1903                                       | 214498 |
| 70  | John Handerson        | T & O Ry Co   | W. Deed      | Apr 27, 1903  | DB 798           | 2564         | Mar 17, 1903                                       | 214498 |
| 71  | John Handerson        | T & O Ry Co   | W. Deed      | Apr 27, 1903  | DB 798           | 2565         | Mar 17, 1903                                       | 214498 |
| 72  | John Handerson        | T & O Ry Co   | W. Deed      | Apr 27, 1903  | DB 798           | 2566         | Mar 17, 1903                                       | 214498 |
| 73  | John Handerson        | T & O Ry Co   | W. Deed      | Apr 27, 1903  | DB 798           | 2567         | Mar 17, 1903                                       | 214498 |
| 74  | John Handerson        | T & O Ry Co   | W. Deed      | Apr 27, 1903  | DB 798           | 2568         | Mar 17, 1903                                       | 214498 |
| 75  | John Handerson        | T & O Ry Co   | W. Deed      | Apr 27, 1903  | DB 798           | 2569         | Mar 17, 1903                                       | 214498 |
| 76  | John Handerson        | T & O Ry Co   | W. Deed      | Apr 27, 1903  | DB 798           | 2570         | Mar 17, 1903                                       | 214498 |
| 77  | John Handerson        | T & O Ry Co   | W. Deed      | Apr 27, 1903  | DB 798           | 2571         | Mar 17, 1903                                       | 214498 |
| 78  | John Handerson        | T & O Ry Co   | W. Deed      | Apr 27, 1903  | DB 798           | 2572         | Mar 17, 1903                                       | 214498 |
| 79  | John Handerson        | T & O Ry Co   | W. Deed      | Apr 27, 1903  | DB 798           | 2573         | Mar 17, 1903                                       | 214498 |
| 80  | John Handerson        | T & O Ry Co   | W. Deed      | Apr 27, 1903  | DB 798           | 2574         | Mar 17, 1903                                       | 214498 |
| 81  | John Handerson        | T & O Ry Co   | W. Deed      | Apr 27, 1903  | DB 798           | 2575         | Mar 17, 1903                                       | 214498 |
| 82  | John Handerson        | T & O Ry Co   | W. Deed      | Apr 27, 1903  | DB 798           | 2576         | Mar 17, 1903                                       | 214498 |
| 83  | John Handerson        | T & O Ry Co   | W. Deed      | Apr 27, 1903  | DB 798           | 2577         | Mar 17, 1903                                       | 214498 |
| 84  | John Handerson        | T & O Ry Co   | W. Deed      | Apr 27, 1903  | DB 798           | 2578         | Mar 17, 1903                                       | 214498 |
| 85  | John Handerson        | T & O Ry Co   | W. Deed      | Apr 27, 1903  | DB 798           | 2579         | Mar 17, 1903                                       | 214498 |
| 86  | John Handerson        | T & O Ry Co   | W. Deed      | Apr 27, 1903  | DB 798           | 2580         | Mar 17, 1903                                       | 214498 |
| 87  | John Handerson        | T & O Ry Co   | W. Deed      | Apr 27, 1903  | DB 798           | 2581         | Mar 17, 1903                                       | 214498 |
| 88  | John Handerson        | T & O Ry Co   | W. Deed      | Apr 27, 1903  | DB 798           | 2582         | Mar 17, 1903                                       | 214498 |
| 89  | John Handerson        | T & O Ry Co   | W. Deed      | Apr 27, 1903  | DB 798           | 2583         | Mar 17, 1903                                       | 214498 |
| 90  | John Handerson        | T & O Ry Co   | W. Deed      | Apr 27, 1903  | DB 798           | 2584         | Mar 17, 1903                                       | 214498 |
| 91  | John Handerson        | T & O Ry Co   | W. Deed      | Apr 27, 1903  | DB 798           | 2585         | Mar 17, 1903                                       | 214498 |
| 92  | John Handerson        | T & O Ry Co   | W. Deed      | Apr 27, 1903  | DB 798           | 2586         | Mar 17, 1903                                       | 214498 |
| 93  | John Handerson        | T & O Ry Co   | W. Deed      | Apr 27, 1903  | DB 798           | 2587         | Mar 17, 1903                                       | 214498 |
| 94  | John Handerson        | T & O Ry Co   | W. Deed      | Apr 27, 1903  | DB 798           | 2588         | Mar 17, 1903                                       | 214498 |
| 95  | John Handerson        | T & O Ry Co   | W. Deed      | Apr 27, 1903  | DB 798           | 2589         | Mar 17, 1903                                       | 214498 |
| 96  | John Handerson        | T & O Ry Co   | W. Deed      | Apr 27, 1903  | DB 798           | 2590         | Mar 17, 1903                                       | 214498 |
| 97  | John Handerson        | T & O Ry Co   | W. Deed      | Apr 27, 1903  | DB 798           | 2591         | Mar 17, 1903                                       | 214498 |
| 98  | John Handerson        | T & O Ry Co   | W. Deed      | Apr 27, 1903  | DB 798           | 2592         | Mar 17, 1903                                       | 214498 |
| 99  | John Handerson        | T & O Ry Co   | W. Deed      | Apr 27, 1903  | DB 798           | 2593         | Mar 17, 1903                                       | 214498 |
| 100 | John Handerson        | T & O Ry Co   | W. Deed      | Apr 27, 1903  | DB 798           | 2594         | Mar 17, 1903                                       | 214498 |

# THIS PROPERTY WAS MERGED WITH  
THE NEW YORK CENTRAL  
RAILROAD COMPANY  
JUNE 30, 1852  
AUTHORIZED IN L. C. C. DOCKET NO. 17700  
RECEIVED JUNE 10, 1852

REVISIONS

| No.  | Date      | Description |
|------|-----------|-------------|
| 1947 | No Change |             |
| 1948 | do        |             |
| 1949 | do        |             |
| 1950 | do        |             |
| 1951 | 4-16-53   |             |
| 1952 | 5-8-54    |             |
| 1953 | No Change |             |
| 1954 | do        |             |
| 1955 | 5-20-57   |             |
| 1956 | 7-28-58   |             |
| 1957 | 11-10-58  |             |

RIGHT OF WAY AND TRACK MAP  
# THE TOLEDO AND OHIO CENTRAL RAILWAY  
OPERATED BY  
THE TOLEDO AND OHIO CENTRAL RAILWAY COMPANY

ST. MARYS BRANCH -- MAIN LINE  
FROM STATION 596+7

Situate in the County of Logan, State of Ohio, and being part of the Penn Central Transportation Company's line of railroad which is known as the St. Mary's Secondary Track and is described in Exhibit A of this Deed, and being all of the real property in the County lying in, under, above, along, contiguous to and adjacent to that part of the line of railroad which lies beyond and initially westerly of the following described lateral cut line:

Being a line distant 820 feet, more or less, measured northwestwardly from the centerline of Troy Street at Station 1066 + 35, as shown on Railroad Valuation Map No. 500-3030-0-12-7, as revised to January 28, 1970.

The part of the line of railroad described herein begins at the lateral cut line near Bellefontaine and extends to the County line near Santa Fe.

The lateral cut line is identified as Line Code 8142-54.7 in the records of the United States Railway Association.

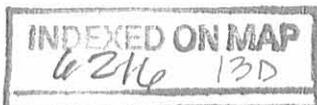

AVS "F" = 7.71 AC. THIS SH. 316.51 AC. TOTAL

8142 - 54.7 AVS

ADDED

| OWNER | VALUATION SUB | SHEET | REAL-ESTATE |
|-------|---------------|-------|-------------|
| 300   | 3033          | 142   | 7           |

LC 8142-17

THIS TRACING IS 50% ORIGINAL SIZE. DRAFTSMAN TO DOUBLE SCALE

PC-CRC-RP158

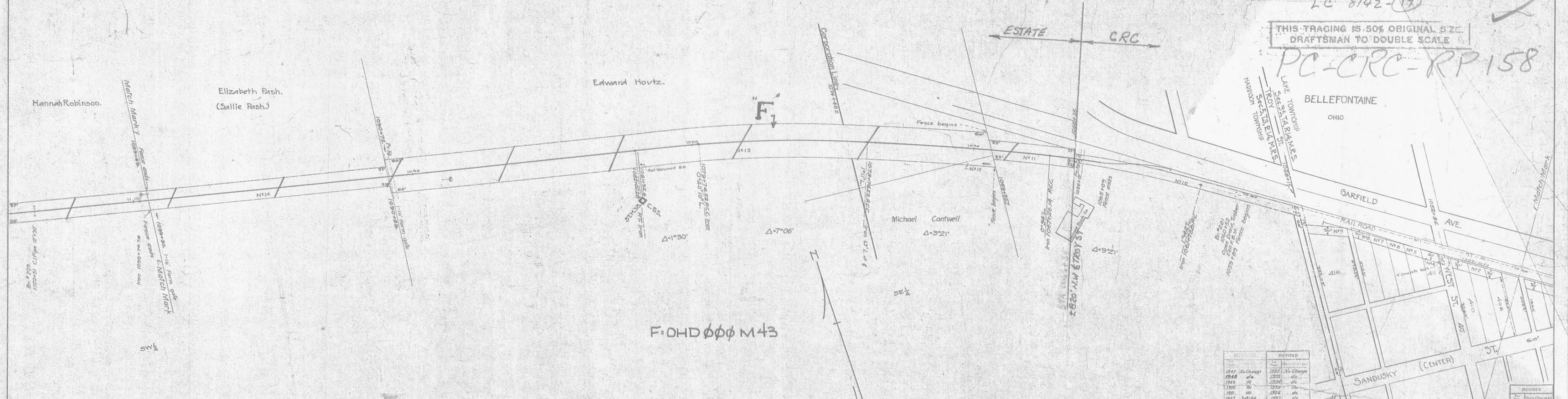

F: OHD 666 M 43

SCHEDULE OF PROPERTY

| No. | Grantor                         | Grantee          | Instrument | Date         | Record       | Cont. No.    | Remarks |   |
|-----|---------------------------------|------------------|------------|--------------|--------------|--------------|---------|---|
| 1   | John M. Hamilton                | John T. Adams    | W. Deed    | Dec 4, 1897  | DB V95 P417  | Apr 19, 1901 | 103463  | Right to use Railroad St. See Note No 1. This deed also conveys parcel #11; this map. Right to cross West St. |
| 2   | Joseph J. Houtgen               | John T. Adams    | W. Deed    | Jan 5, 1898  | DB V95 P450  | Apr 19, 1901 | 103464  | See Note No 1   |
| 3   | D. W. Huffer                    | John T. Adams    | W. Deed    | Dec 25, 1898 | DB V95 P415  | Apr 19, 1901 | 103465  | See Note No 1   |
| 4   | Walter S. Plum                  | John T. Adams    | W. Deed    | Jan 18, 1898 | DB V95 P441  | Apr 23, 1901 | 103466  | See Note No 1   |
| 5   | Adams L. Oden                   | John T. Adams    | W. Deed    | Jan 19, 1898 | DB V95 P436  | Apr 23, 1901 | 103467  | See Note No 1   |
| 6   | Sam'l Buchanan                  | John T. Adams    | W. Deed    | Jan 1, 1898  | DB V95 P402  | Apr 17, 1901 | 103468  | See Note No 1   |
| 7   | Robert B. Seurif                | John T. Adams    | W. Deed    | Jan 1, 1898  | DB V95 P450  | Apr 24, 1901 | 103469  | See Note No 1   |
| 8   | The Bellefontaine 2 & O C Ry Co | John T. Adams    | W. Deed    | Jan 12, 1901 | DB V96 P219  | Sep 23, 1901 | 103460  |   |
| 9   | John T. Adams                   | John T. Adams    | Q.C. Deed  | Jan 26, 1902 | DB V96 P545  | Feb 10, 1902 | 103468  | See Note No 1   |
| 10  | John T. Adams                   | John T. Adams    | W. Deed    | Dec 24, 1907 | DB V95 P460  | Apr 17, 1901 | 103469  | See Note No 1   |
| 11  | Elizabeth Pash                  | John T. Adams    | W. Deed    | Nov 12, 1897 | DB V95 P460  | Apr 23, 1901 | 103464  | See Note No 1   |
| 12  | Edw. Houtz                      | T. & O. C. Ry Co | Q.C. Deed  | Jan 19, 1918 | DB V107 P430 | July 5, 1928 | 1066992 | Release Undercrossing   |

Note:-

No 1 - Conveyed to D & L N Ry Co by John T. Adams & J. C. Deed Feb 10, 1899. Recorded Vol 95 P460 Apr 19, 1901. Cust. No. 1271.

LOGAN COUNTY  
LAKE TOWNSHIP  
HARRISON TOWNSHIP

| REVISED | REVISION  | REVISED | REVISION  |
|---------|-----------|---------|-----------|
| 1847    | No Change | 1932    | No Change |
| 1848    | do        | 1933    | do        |
| 1849    | do        | 1934    | do        |
| 1850    | do        | 1935    | do        |
| 1851    | do        | 1936    | do        |
| 1852    | 3-5-54    | 1937    | do        |
| 1853    | No Change | 1938    | do        |
| 1854    | do        | 1939    | do        |
| 1855    | 5-20-57   | 1940    | do        |
| 1856    | No Change | 1941    | do        |
| 1857    | do        | 1942    | do        |
| 1858    | 1-20-70   | 1943    | do        |
|         |           | 1944    | do        |
|         |           | 1945    | do        |
|         |           | 1946    | do        |

# THIS PROPERTY WAS MERGED WITH THE NEW YORK CENTRAL RAILROAD COMPANY JUNE 28, 1932 AUTHORIZED BY I. C. C. DCKET NO. 17700 RECORDED JUNE 18, 1932

# THE TOLEDO AND OHIO CENTRAL RAILWAY OPERATED BY

THE TOLEDO AND OHIO CENTRAL RAILWAY COMPANY

ST. MARYS BRANCH -- MAIN LINE FROM STATION 1050+00 TO STATION 1099+45. SCALE 1 INCH = 100 FEET JUNE 30, 1918

OFFICE OF VALUATION ENGINEER, COLUMBUS, OHIO. OPERATED BY THE NEW YORK CENTRAL RAILROAD COMPANY SUBSEQUENT TO DECEMBER 31, 1921.

| REVISED | REVISION  |
|---------|-----------|
| 1859    | No Change |
| 1860    | No Change |
| 1861    | No Change |
| 1862    | No Change |
| 1863    | No Change |
| 1864    | No Change |
| 1865    | No Change |
| 1866    | No Change |
| 1867    | No Change |
| 1868    | No Change |
| 1869    | No Change |
| 1870    | No Change |
| 1871    | No Change |
| 1872    | No Change |
| 1873    | No Change |
| 1874    | No Change |
| 1875    | No Change |
| 1876    | No Change |
| 1877    | No Change |
| 1878    | No Change |
| 1879    | No Change |
| 1880    | No Change |
| 1881    | No Change |
| 1882    | No Change |
| 1883    | No Change |
| 1884    | No Change |
| 1885    | No Change |
| 1886    | No Change |
| 1887    | No Change |
| 1888    | No Change |
| 1889    | No Change |
| 1890    | No Change |
| 1891    | No Change |
| 1892    | No Change |
| 1893    | No Change |
| 1894    | No Change |
| 1895    | No Change |
| 1896    | No Change |
| 1897    | No Change |
| 1898    | No Change |
| 1899    | No Change |
| 1900    | No Change |

V-303 12

V-3 12

INDEXED ON MAP 6216 125

AYS - R.O.W. - F = 17.64 AC.

13.45

VALUATION SUB SHEET REAL ESTATE  
OWNER SECTION DIV. NUMBER REGION  
500 3030 0 13

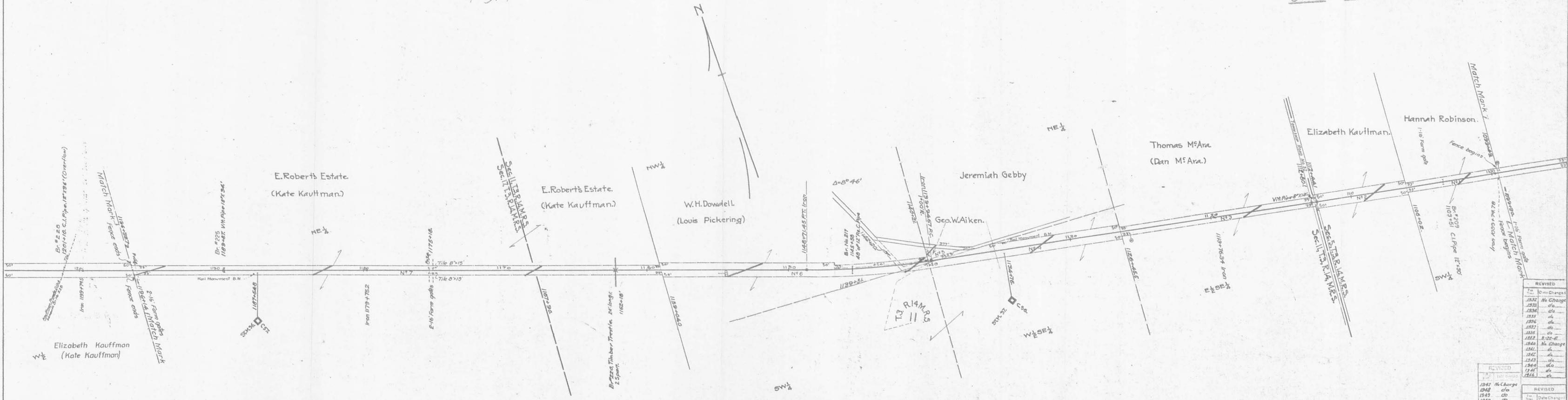

F - OH. D 0000 M 43

| No. | Grantor                | Grantee       | Instrument | Date         | Record       | Cont. No.              | Remarks  |
|-----|------------------------|---------------|------------|--------------|--------------|------------------------|--|
| 1   | Hannah Robinson        | John T. Adams | W. Deed    | Dec 27, 1897 | DB V95 P444  | Apr 24, 1901 1468 1/2  | See Note No. 1                                   |
| 2   | Elizabeth Kauffman     | John T. Adams | W. Deed    | Dec 1, 1897  | DB V95 P420  | Apr 19, 1901 1466 1/2  | See Note No. 1                                   |
| 3   | Thos. Mearns           | John T. Adams | W. Deed    | Dec 24, 1897 | DB V95 P420  | Apr 19, 1901 1466 1/2  | See Note No. 1                                   |
| 4   | Jerry M. Gebby         | John T. Adams | W. Deed    | Jan 11, 1898 | DB V95 P420  | Apr 19, 1901 1466 1/2  | See Note No. 1                                   |
| 5   | Geo. W. Aikin          | John T. Adams | W. Deed    | Dec 30, 1897 | DB V95 P398  | Apr 16, 1901 1466 1/2  | See Note No. 1                                   |
| 6   | W. H. Dowdell          | John T. Adams | W. Deed    | Dec 20, 1897 | DB V95 P409  | Apr 17, 1901 1466 1/2  | See Note No. 1                                   |
| 7   | Emmette Roberts, et al | John T. Adams | W. Deed    | Nov 12, 1897 | DB V95 P444  | Apr 24, 1901 1468 1/2  | See Note No. 1                                   |
| 8   | Louis Pickering et al  | T&O R.R. Co.  | G.C. Deed  | Aug 19, 1927 | DB V132 P420 | Sept 14, 1927 4800 1/2 | Release of Under-Crossing, Comp. Report No. 719. |

Note: - Conveyed to D & L R Ry Co by John T. Adams by G.C. Deed Feb 10, 1899. Recorded Vol. 95 P460 Apr 29, 1901. Cont. No. 1317

LOGAN COUNTY  
HARRISON TOWNSHIP

THIS TRACING IS 50% ORIGINAL SIZE  
DRAFTSMAN TO DOUBLE SCALE

SHEET NO. 14 OF 24 OF THE TOLEDO AND OHIO CENTRAL RAILWAY.  
BY ST. MARYS BRANCH - MAIN LINE.  
FIELD SURVEY SECTION 1099+49 TO SURVEY STATION 1186+33.7

# THIS PROPERTY WAS MERGED WITH  
THE NEW YORK CENTRAL  
RAILROAD COMPANY  
JUNE 30, 1952  
ANNOUNCED IN I. C. C. BROCKETT NO. 17700  
ISSUED JUNE 18, 1952  
RIGHT OF WAY AND TRACK MAP  
OPERATED BY  
# THE TOLEDO AND OHIO CENTRAL RAILWAY COMPANY

ST. MARYS BRANCH - MAIN LINE  
FROM STATION 1099+49. TO STATION 1186+33.7  
SCALE 1 INCH = 200 FEET JUNE 30, 1918  
OFFICE OF VALUATION ENGINEER, COLUMBUS, OHIO.  
\* OPERATED BY THE NEW YORK CENTRAL RAILROAD COMPANY SUBSEQUENT TO DECEMBER 31, 1921.  
CORRECTED AS OF JAN. 1 1921  
OFFICE OF VALUATION ENGINEER, CLEVELAND, OHIO

| REVISED | Yr.       | Date Change |
|---------|-----------|-------------|
| 1892    | No Change |             |
| 1893    | No Change |             |
| 1894    | No Change |             |
| 1895    | No Change |             |
| 1896    | No Change |             |
| 1897    | No Change |             |
| 1898    | No Change |             |
| 1899    | No Change |             |
| 1900    | No Change |             |
| 1901    | No Change |             |
| 1902    | No Change |             |
| 1903    | No Change |             |
| 1904    | No Change |             |
| 1905    | No Change |             |
| 1906    | No Change |             |
| 1907    | No Change |             |
| 1908    | No Change |             |
| 1909    | No Change |             |
| 1910    | No Change |             |
| 1911    | No Change |             |
| 1912    | No Change |             |
| 1913    | No Change |             |
| 1914    | No Change |             |
| 1915    | No Change |             |
| 1916    | No Change |             |
| 1917    | No Change |             |
| 1918    | No Change |             |
| 1919    | No Change |             |
| 1920    | No Change |             |
| 1921    | No Change |             |
| 1922    | No Change |             |
| 1923    | No Change |             |
| 1924    | No Change |             |
| 1925    | No Change |             |
| 1926    | No Change |             |
| 1927    | No Change |             |
| 1928    | No Change |             |
| 1929    | No Change |             |
| 1930    | No Change |             |
| 1931    | No Change |             |
| 1932    | No Change |             |
| 1933    | No Change |             |
| 1934    | No Change |             |
| 1935    | No Change |             |
| 1936    | No Change |             |
| 1937    | No Change |             |
| 1938    | No Change |             |
| 1939    | No Change |             |
| 1940    | No Change |             |
| 1941    | No Change |             |
| 1942    | No Change |             |
| 1943    | No Change |             |
| 1944    | No Change |             |
| 1945    | No Change |             |
| 1946    | No Change |             |
| 1947    | No Change |             |
| 1948    | No Change |             |
| 1949    | No Change |             |
| 1950    | No Change |             |
| 1951    | No Change |             |
| 1952    | No Change |             |
| 1953    | No Change |             |
| 1954    | No Change |             |
| 1955    | No Change |             |
| 1956    | No Change |             |
| 1957    | No Change |             |
| 1958    | No Change |             |
| 1959    | No Change |             |
| 1960    | No Change |             |
| 1961    | No Change |             |
| 1962    | No Change |             |
| 1963    | No Change |             |
| 1964    | No Change |             |
| 1965    | No Change |             |
| 1966    | No Change |             |
| 1967    | No Change |             |
| 1968    | No Change |             |
| 1969    | No Change |             |
| 1970    | No Change |             |
| 1971    | No Change |             |
| 1972    | No Change |             |
| 1973    | No Change |             |
| 1974    | No Change |             |
| 1975    | No Change |             |
| 1976    | No Change |             |
| 1977    | No Change |             |
| 1978    | No Change |             |
| 1979    | No Change |             |
| 1980    | No Change |             |
| 1981    | No Change |             |
| 1982    | No Change |             |
| 1983    | No Change |             |
| 1984    | No Change |             |
| 1985    | No Change |             |
| 1986    | No Change |             |
| 1987    | No Change |             |
| 1988    | No Change |             |
| 1989    | No Change |             |
| 1990    | No Change |             |
| 1991    | No Change |             |
| 1992    | No Change |             |
| 1993    | No Change |             |
| 1994    | No Change |             |
| 1995    | No Change |             |
| 1996    | No Change |             |
| 1997    | No Change |             |
| 1998    | No Change |             |
| 1999    | No Change |             |
| 2000    | No Change |             |

V-303  
13  
INDEXED ON MAP  
6216 HPI

| OWNER | VALUATION SECTION | SUB DIV. NUMBER | SHEET NUMBER | REAL ESTATE REGION |
|-------|-------------------|-----------------|--------------|--------------------|
| 500   | 3030              | 14              | 7            |                    |

THIS TRACING IS 50% ORIGINAL SIZE.  
DRAFTSMAN TO DOUBLE SCALE.



AVS - R.O.W-F = 22.50

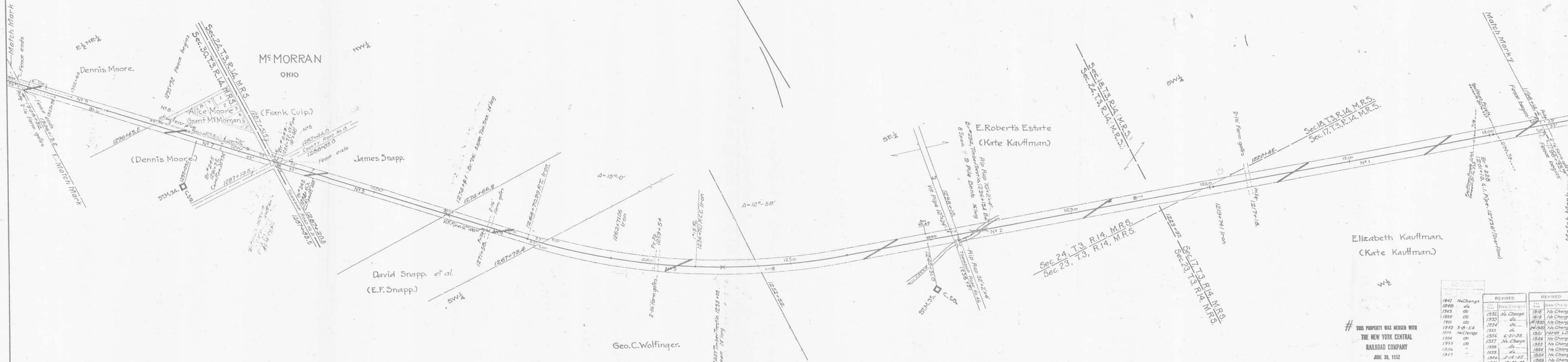

| No. | Grant or              | Grantee       | Instrument | Date         | Record      | Cont. No.           | Remarks        |
|-----|-----------------------|---------------|------------|--------------|-------------|---------------------|----------------|
| 1   | Elizabeth Kempton     | John T. Adams | W. Deed    | Dec 1, 1897  | DB Y96 P425 | Apr 19, 1901 143466 | See Note No. 1 |
| 2   | Emmette Roberts et al | John T. Adams | W. Deed    | Dec 13, 1897 | DB Y96 P444 | Apr 24, 1901 143493 | See Note No. 1 |
| 3   | Geo. C. Wolfinger     | John T. Adams | W. Deed    | Dec 24, 1897 | DB Y96 P453 | Apr 26, 1901 143492 | See Note No. 1 |
| 4   | David Snapp, et al    | J. T. Adams   | W. Deed    | Dec 10, 1897 | DB Y95 P449 | Apr 24, 1901 143493 | See Note No. 1 |
| 5   | Jan. W. Snapp         | John T. Adams | W. Deed    | Dec 13, 1897 | DB Y96 P447 | Apr 24, 1901 143494 | See Note No. 1 |
| 6   | Alice Moore           | John T. Adams | W. Deed    | Dec 16, 1897 | DB Y96 P430 | Apr 27, 1901 143495 | See Note No. 1 |
| 7   | Grant McMoran         | T & O C Ry Co | W. Deed    | Nov 24, 1912 | DB V18 P562 | Nov 20, 1912 147476 | See Note No. 1 |
| 8   | Grant McMoran         | T & O C Ry Co | W. Deed    | Dec 24, 1897 | DB Y95 P437 | Apr 22, 1901 143497 | See Note No. 1 |
| 9   | Dennis Moore          | John T. Adams | W. Deed    | Dec 24, 1897 | DB Y95 P437 | Apr 22, 1901 143497 | See Note No. 1 |

Note: -  
No. 1 - Conveyed to D & L H By Co by John T. Adams by G.C. Deed  
Feb 18, 1899. Recorded Vol. 95 P460 Apr 29, 1901. Cont. No. 1317

LOGAN COUNTY  
HARRISON TOWNSHIP

| REVISED | REVISED | REVISED | REVISED |
|---------|---------|---------|---------|
| Date    | Date    | Date    | Date    |
| 1897    | 1897    | 1897    | 1897    |
| 1898    | 1898    | 1898    | 1898    |
| 1899    | 1899    | 1899    | 1899    |
| 1900    | 1900    | 1900    | 1900    |
| 1901    | 1901    | 1901    | 1901    |
| 1902    | 1902    | 1902    | 1902    |
| 1903    | 1903    | 1903    | 1903    |
| 1904    | 1904    | 1904    | 1904    |
| 1905    | 1905    | 1905    | 1905    |
| 1906    | 1906    | 1906    | 1906    |
| 1907    | 1907    | 1907    | 1907    |
| 1908    | 1908    | 1908    | 1908    |
| 1909    | 1909    | 1909    | 1909    |
| 1910    | 1910    | 1910    | 1910    |
| 1911    | 1911    | 1911    | 1911    |
| 1912    | 1912    | 1912    | 1912    |
| 1913    | 1913    | 1913    | 1913    |
| 1914    | 1914    | 1914    | 1914    |
| 1915    | 1915    | 1915    | 1915    |
| 1916    | 1916    | 1916    | 1916    |
| 1917    | 1917    | 1917    | 1917    |
| 1918    | 1918    | 1918    | 1918    |
| 1919    | 1919    | 1919    | 1919    |
| 1920    | 1920    | 1920    | 1920    |
| 1921    | 1921    | 1921    | 1921    |
| 1922    | 1922    | 1922    | 1922    |
| 1923    | 1923    | 1923    | 1923    |
| 1924    | 1924    | 1924    | 1924    |
| 1925    | 1925    | 1925    | 1925    |
| 1926    | 1926    | 1926    | 1926    |
| 1927    | 1927    | 1927    | 1927    |
| 1928    | 1928    | 1928    | 1928    |
| 1929    | 1929    | 1929    | 1929    |
| 1930    | 1930    | 1930    | 1930    |
| 1931    | 1931    | 1931    | 1931    |
| 1932    | 1932    | 1932    | 1932    |
| 1933    | 1933    | 1933    | 1933    |
| 1934    | 1934    | 1934    | 1934    |
| 1935    | 1935    | 1935    | 1935    |
| 1936    | 1936    | 1936    | 1936    |
| 1937    | 1937    | 1937    | 1937    |
| 1938    | 1938    | 1938    | 1938    |
| 1939    | 1939    | 1939    | 1939    |
| 1940    | 1940    | 1940    | 1940    |
| 1941    | 1941    | 1941    | 1941    |
| 1942    | 1942    | 1942    | 1942    |
| 1943    | 1943    | 1943    | 1943    |
| 1944    | 1944    | 1944    | 1944    |
| 1945    | 1945    | 1945    | 1945    |
| 1946    | 1946    | 1946    | 1946    |

# THIS PROPERTY WAS MERGED WITH  
THE NEW YORK CENTRAL  
RAILROAD COMPANY  
JUNE 30, 1952  
ANNOUNCED IN L.C.C. DOCKET NO. 17700  
HEARD JUNE 10, 1952  
RIGHT OF WAY AND TRACK MAP  
# THE TOLEDO AND OHIO CENTRAL RAILWAY  
OPERATED BY  
THE TOLEDO AND OHIO CENTRAL RAILWAY COMPANY

ST. MARYS BRANCH -- MAIN LINE  
FROM STATION 1196+33.7 TO STATION 1306+13.5  
SCALE 1 INCH = 200 FEET  
JUNE 30, 1918  
OFFICE OF VALUATION ENGINEER, COLUMBUS, OHIO.  
\* OPERATED BY THE NEW YORK CENTRAL RAILROAD  
COMPANY SUBSEQUENT TO DECEMBER 31, 1921.  
CORRECTED AS OF JAN. 1, 1921  
OFFICE OF VALUATION ENGINEER, CLEVELAND, OHIO

INDEXED ON MAP  
0216 14P-2



17.98

AMS-R.O.W-F=18.07 AC.

OWNER 500 VALUATION SUB SECTION DIV. 3030 SHEET NUMBER 15 REAL ESTATE REGION

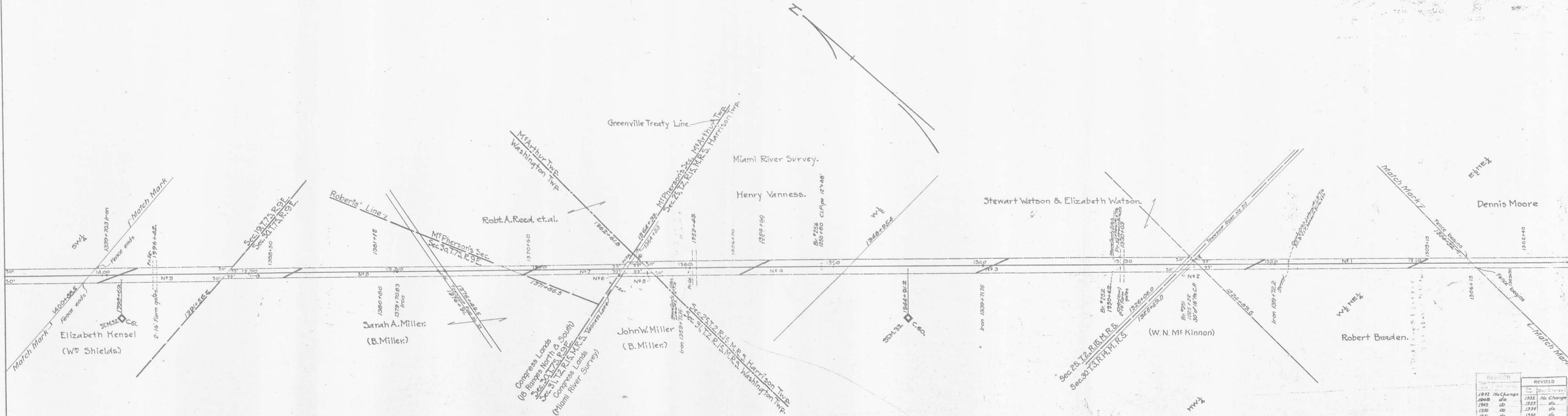

D-04.D000M43

**SCHEDULE OF PROPERTY**

| No. | Grantor  | Grantee       | Instrument | Date         | Record       | Cont.No.  | Remarks |
|-----|--|---------------|------------|--------------|--------------|---|---------|
| 1   | Robert Braden  | John T. Adams | W. Deed    | Dec 27, 1897 | DB V95 P399  | Apr 16, 1901 1498/12 See Note No.1                                  |         |
| 2   | No paper title found.                                    |               |            |              |              | 1499/10   |         |
| 3   | Stewart Watson   | John T. Adams | W. Deed    | Nov 17, 1897 | DB V95 P453  | Apr 26, 1901 1498/12 See Note No.1                                  |         |
| 4   | Henry Van Ness   | John T. Adams | W. Deed    | Nov 17, 1897 | DB V95 P453  | Apr 26, 1901 1498/12 See Note No.1                                  |         |
| 5   | John W. Miller   | T & O Ry Co   | W. Deed    | May 7, 1902  | DB V96 P208  | July 12, 1902 1498/13   |         |
| 6   | This parcel conveyed in same deed as parcel #4, this map |               |            |              |              |   |         |
| 7   | Rob't. A. Reed, et al                                    | John T. Adams | W. Deed    | Jan 4, 1899  | DB V95 P443  | Apr 24, 1901 1498/12 See Note No.1                                  |         |
| 8   | Sarah A. Miller  | John T. Adams | W. Deed    | Nov 20, 1897 | DB V95 P433  | Apr 27, 1901 1498/12 See Note No.1                                  |         |
| 9   | Elizabeth Kensel   | T & O Ry Co   | W. Deed    | Nov 9, 1906  | DB V104 P305 | Nov 10, 1906 1498/14  |         |
| 4   | Elizabeth Kensel   | T & O Ry Co   | W. Deed    | Aug 1, 1930  | DB V143 P345 | Sept 4, 1930 3047/12 Release of cattle pass. Comp. Report No. AB15. |         |
| 1   | Robert Braden  | T & O Ry Co   | W. Deed    | Apr 30, 1931 | DB V141 P220 | May 26, 1931 3070/12 Release of cattle pass. Comp. Report No. 1517  |         |

No.1 - Conveyed to D & E Ry Co by John T. Adams by Q.C. Deed Feb 18, 1898. Recorded Vol.95 P460 Apr 29, 1901. Cont.No.1517

THIS TRACING IS 50% ORIGINAL SIZE DRAFTSMAN TO DOUBLE SCALE

| REVISED | REVISED     | REVISED |
|---------|-------------|---------|
| Year    | Date Change | Year    |
| 1881    | No Change   | 1881    |
| 1882    | No Change   | 1882    |
| 1883    | No Change   | 1883    |
| 1884    | No Change   | 1884    |
| 1885    | No Change   | 1885    |
| 1886    | No Change   | 1886    |
| 1887    | No Change   | 1887    |
| 1888    | No Change   | 1888    |
| 1889    | No Change   | 1889    |
| 1890    | No Change   | 1890    |
| 1891    | No Change   | 1891    |
| 1892    | No Change   | 1892    |
| 1893    | No Change   | 1893    |
| 1894    | No Change   | 1894    |
| 1895    | No Change   | 1895    |
| 1896    | No Change   | 1896    |
| 1897    | No Change   | 1897    |
| 1898    | No Change   | 1898    |
| 1899    | No Change   | 1899    |
| 1900    | No Change   | 1900    |
| 1901    | No Change   | 1901    |
| 1902    | No Change   | 1902    |
| 1903    | No Change   | 1903    |
| 1904    | No Change   | 1904    |
| 1905    | No Change   | 1905    |
| 1906    | No Change   | 1906    |
| 1907    | No Change   | 1907    |
| 1908    | No Change   | 1908    |
| 1909    | No Change   | 1909    |
| 1910    | No Change   | 1910    |
| 1911    | No Change   | 1911    |
| 1912    | No Change   | 1912    |
| 1913    | No Change   | 1913    |
| 1914    | No Change   | 1914    |
| 1915    | No Change   | 1915    |
| 1916    | No Change   | 1916    |
| 1917    | No Change   | 1917    |
| 1918    | No Change   | 1918    |
| 1919    | No Change   | 1919    |
| 1920    | No Change   | 1920    |

# THIS PROPERTY WAS MERGED WITH THE NEW YORK CENTRAL RAILROAD COMPANY  
 JUNE 30, 1932  
 APPROVED BY I.C.C. DOCKET NO. 17700  
 RECEIVED JUNE 18, 1932

RIGHT OF WAY AND TRACK MAP  
 # THE TOLEDO AND OHIO CENTRAL RAILWAY COMPANY  
 OPERATED BY  
 THE TOLEDO AND OHIO CENTRAL RAILWAY COMPANY

ST. MARYS BRANCH -- MAIN LINE  
 FROM STATION 1306+13.5 TO STATION 1400+85.5  
 SCALE 1 INCH = 200 FEET  
 JUNE 30, 1918

OFFICE OF VALUATION ENGINEER, COLUMBUS, OHIO.  
 \* OPERATED BY THE NEW YORK CENTRAL RAILROAD COMPANY SUBSEQUENT TO DECEMBER 31, 1921.  
 CORRECTED AS OF JAN. 1, 1920  
 OFFICE OF VALUATION ENGINEER, CLEVELAND, OHIO

INDEXED ON MAP  
 6216 1153  
 A-14-2-16

21.47

AVS - R.O.W - F = 21.47 AC.

|                                  |
|----------------------------------|
| VALUATION SUB SHEET REAL ESTATE  |
| OWNER SECTION DIV. NUMBER REGION |
| 500 3030 16 7                    |

THIS TRACING IS 50% ORIGINAL SIZE. DRAFTSMAN TO DOUBLE SCALE

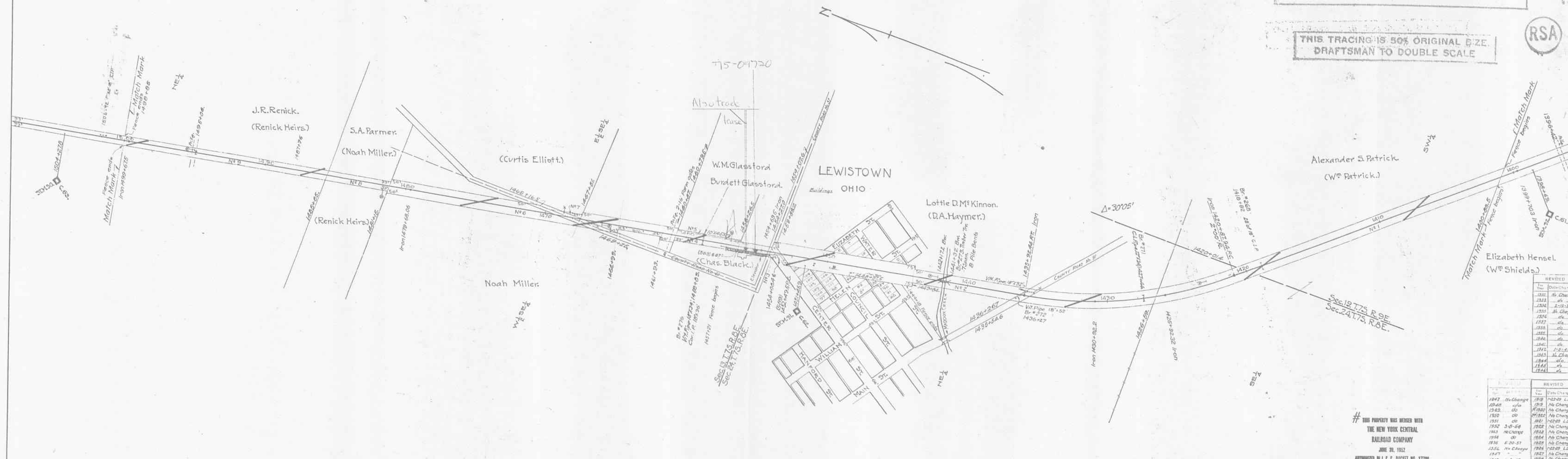

| No | Grantor               | Grantee   | Instrument | Date          | Record      | Dist. No.       | Remarks   |
|----|-----------------------|---|------------|---------------|-------------|-----------------|---|
| 1  | A. S. Patrick         | John T. Adams                                   | W. Deed    | Nov 17, 1897  | DB V98 P437 | Apr 23, 1901    | 1466/7 See Note No. 1   |
| 2  | Lottie D. McKinnon    | John T. Adams                                   | W. Deed    | Dec 24, 1897  | DB V96 P427 | Apr 22, 1901    | 1466/2 See Note No. 1   |
| 3  | W. M. Glasford et al  | T & O C Ry Co                                   | W. Deed    | Apr 19, 1901  | DB V98 P465 | June 15, 1901   | 1469/7  |
| 4  | Burlette Glasford     | T & O C Ry Co                                   | W. Deed    | Sept 23, 1913 | DB V114 P18 | Sup't. 27, 1913 | 1490/7  |
| 5  | Noah Miller           | John T. Adams                                   | W. Deed    | Feb 21, 1898  | DB V96 P434 | Apr 22, 1901    | 1466/3 See Note No. 1   |
| 6  | No paper title found. | Held by adverse possession and claimed by Ry Co |            |               |             |                 | 1492/7  |
| 7  | S. A. Parmer          | T & O C Ry Co                                   | W. Deed    | Apr 15, 1901  | DB V96 P428 | Sept 24, 1901   | 1495/7  |
| 8  | John R. Renick        | John T. Adams                                   | W. Deed    | Dec 24, 1897  | DB V98 P443 | Apr 24, 1901    | 1469/8 See Note No. 1. This parcel continued as parcel #1. Map 17 |

Note:-  
No. 1 - Conveyed to D & L N Ry Co by John T. Adams by G. C. Deed Feb 18, 1898. Recorded Vol. 96 P460 Apr 29, 1901. Cust. No. 1317

OF 0420001143

LOGAN COUNTY WASHINGTON TOWNSHIP

303-17

V6-P15-F1

| REVISED | TH        | Date Change |
|---------|-----------|-------------|
| 1872    | No Change |             |
| 1873    | No Change |             |
| 1874    | No Change |             |
| 1875    | No Change |             |
| 1876    | No Change |             |
| 1877    | No Change |             |
| 1878    | No Change |             |
| 1879    | No Change |             |
| 1880    | No Change |             |
| 1881    | No Change |             |
| 1882    | No Change |             |
| 1883    | No Change |             |
| 1884    | No Change |             |
| 1885    | No Change |             |
| 1886    | No Change |             |
| 1887    | No Change |             |
| 1888    | No Change |             |
| 1889    | No Change |             |
| 1890    | No Change |             |
| 1891    | No Change |             |
| 1892    | No Change |             |
| 1893    | No Change |             |
| 1894    | No Change |             |
| 1895    | No Change |             |
| 1896    | No Change |             |
| 1897    | No Change |             |
| 1898    | No Change |             |
| 1899    | No Change |             |
| 1900    | No Change |             |

# THIS PROPERTY WAS MERGED WITH  
THE NEW YORK CENTRAL  
RAILROAD COMPANY  
JUNE 30, 1952  
AUTHORIZED BY L.C.C. Docket No. 17700  
RESOLVED JUNE 10, 1952

# THE TOLEDO AND OHIO CENTRAL RAILWAY  
OPERATED BY  
THE TOLEDO AND OHIO CENTRAL RAILWAY COMPANY

ST. MARYS BRANCH -- MAIN LINE  
FROM STATION 1400+88.5 TO STATION 1500+00  
SCALE 1 INCH = 200 FEET  
JUNE 30, 1918  
OFFICE OF VALUATION ENGINEER, COLUMBUS, OHIO.  
\* OPERATED BY THE NEW YORK CENTRAL RAILROAD COMPANY SUBSEQUENT TO DECEMBER 31, 1921.  
CORRECTED AS OF JAN. 1 1931  
OFFICE OF VALUATION ENGINEER, CLEVELAND, OHIO

V-303 16

V-3 16

INDEXED ON MAP 6216 1424

ANS - R.O.W.F = 16.05 AC.

OWNER  
500

VALUATION SECTION DIV. NUMBER  
3030 0 17

SHEET NUMBER  
17

REAL ESTATE REGION

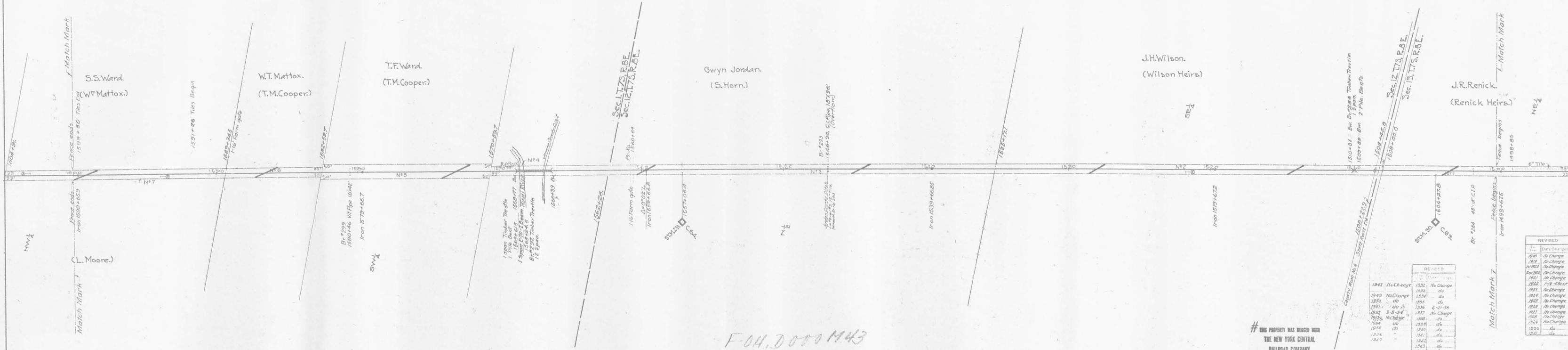

SCHEDULE OF PROPERTY

| No. | Grantor                     | Grantee           | Instrument | Date         | Record      | Cust. No.              | Remarks   |
|-----|-----------------------------|-------------------|------------|--------------|-------------|------------------------|---|
| 1   | John H. Pentick             | John T. Adams     | W. Deed    | Dec 24, 1897 | DB 756 P415 | Apr 24, 1901 / 764494  | See Note No. 1 This is a part of parcel #9, Map 16        |
| 2   | J. H. Wilson et al          | John T. Adams     | W. Deed    | Dec 24, 1897 | DB 756 P454 | Apr 26, 1901 / 774494  | See Note No. 1  |
| 3   | Mary H. Jordan              | T & O C Ry Co     | U. Deed    | Apr 19, 1901 | DB 756 P566 | June 17, 1901 / 773446 |   |
| 4   | State Board of Public Works | John T. Adams     | W. Deed    | Dec 20, 1897 | DB 756 P415 | Apr 24, 1901 / 764494  | Right to cross Miami River                                |
| 5   | John T. Adams               | John T. Adams     | W. Deed    | Apr 2, 1898  | DB 756 P454 | Apr 25, 1901 / 773446  | See Note No. 1  |
| 6   | W. T. Mattox                | John T. Adams     | W. Deed    | Apr 2, 1898  | DB 756 P455 | Apr 22, 1901 / 773446  | See Note No. 1  |
| 7   | S. T. Ward                  | John T. Adams     | W. Deed    | Dec 21, 1897 | DB 756 P456 | Apr 27, 1901 / 773446  | See Note No. 1 This parcel is a part of parcel #1, Map 16 |
| 8   | E. B. Miller, et al         | T. & O. C. Ry Co. | Release    | May 25, 1936 | DB 756 P571 | June 1, 1936 / 226     | Release of cattle pass right, A.T.E. 41586                |

Notes -  
No. 1 - Conveyed to D & I N Co by John T. Adams by G.C. Deed Feb 16, 1897. Recorded Vol. 95 P460 Apr 29, 1901. Cust. No. 1217.

REVISIONS

| Date | Description |
|------|-------------|
| 1942 | No Change   |
| 1949 | No Change   |
| 1950 | No Change   |
| 1951 | No Change   |
| 1952 | No Change   |
| 1953 | No Change   |
| 1954 | No Change   |
| 1955 | No Change   |
| 1956 | No Change   |
| 1957 | No Change   |
| 1958 | No Change   |
| 1959 | No Change   |
| 1960 | No Change   |
| 1961 | No Change   |
| 1962 | No Change   |
| 1963 | No Change   |
| 1964 | No Change   |
| 1965 | No Change   |
| 1966 | No Change   |
| 1967 | No Change   |
| 1968 | No Change   |
| 1969 | No Change   |
| 1970 | No Change   |
| 1971 | No Change   |
| 1972 | No Change   |
| 1973 | No Change   |
| 1974 | No Change   |
| 1975 | No Change   |
| 1976 | No Change   |
| 1977 | No Change   |
| 1978 | No Change   |
| 1979 | No Change   |
| 1980 | No Change   |
| 1981 | No Change   |
| 1982 | No Change   |
| 1983 | No Change   |
| 1984 | No Change   |
| 1985 | No Change   |
| 1986 | No Change   |
| 1987 | No Change   |
| 1988 | No Change   |
| 1989 | No Change   |
| 1990 | No Change   |
| 1991 | No Change   |
| 1992 | No Change   |
| 1993 | No Change   |
| 1994 | No Change   |
| 1995 | No Change   |
| 1996 | No Change   |
| 1997 | No Change   |
| 1998 | No Change   |
| 1999 | No Change   |
| 2000 | No Change   |

THIS TRACING IS 50% ORIGINAL SIZE.  
DRAFTSMAN TO DOUBLE SCALE

LOGAN COUNTY  
WASHINGTON TOWNSHIP

# THIS PROPERTY WAS MERGED WITH  
THE NEW YORK CENTRAL  
RAILROAD COMPANY  
JUNE 30, 1952  
AUTHORIZED BY L. C. C. DOCKET NO. 17700  
RECORDED JUNE 10, 1952

RIGHT OF WAY AND TRACK MAP  
# THE TOLEDO AND OHIO CENTRAL RAILWAY  
OPERATED BY  
THE TOLEDO AND OHIO CENTRAL RAILWAY COMPANY

ST. MARYS BRANCH -- MAIN LINE  
FROM STATION 1500+00 TO STATION 1600+00  
SCALE 1" INCH = 200 FEET  
JUNE 30, 1918

OFFICE OF VALUATION ENGINEER, COLUMBUS, OHIO  
CORRECTED AS OF JAN. 1, 1952  
OFFICE OF VALUATION ENGINEER, CLEVELAND, OHIO  
OPERATED BY THE NEW YORK CENTRAL RAILROAD COMPANY SUBSEQUENT TO DECEMBER 31, 1921

INDEXED ON MAP  
6216 14P5

REVISIONS

| Date | Description |
|------|-------------|
| 1942 | No Change   |
| 1949 | No Change   |
| 1950 | No Change   |
| 1951 | No Change   |
| 1952 | No Change   |
| 1953 | No Change   |
| 1954 | No Change   |
| 1955 | No Change   |
| 1956 | No Change   |
| 1957 | No Change   |
| 1958 | No Change   |
| 1959 | No Change   |
| 1960 | No Change   |
| 1961 | No Change   |
| 1962 | No Change   |
| 1963 | No Change   |
| 1964 | No Change   |
| 1965 | No Change   |
| 1966 | No Change   |
| 1967 | No Change   |
| 1968 | No Change   |
| 1969 | No Change   |
| 1970 | No Change   |
| 1971 | No Change   |
| 1972 | No Change   |
| 1973 | No Change   |
| 1974 | No Change   |
| 1975 | No Change   |
| 1976 | No Change   |
| 1977 | No Change   |
| 1978 | No Change   |
| 1979 | No Change   |
| 1980 | No Change   |
| 1981 | No Change   |
| 1982 | No Change   |
| 1983 | No Change   |
| 1984 | No Change   |
| 1985 | No Change   |
| 1986 | No Change   |
| 1987 | No Change   |
| 1988 | No Change   |
| 1989 | No Change   |
| 1990 | No Change   |
| 1991 | No Change   |
| 1992 | No Change   |
| 1993 | No Change   |
| 1994 | No Change   |
| 1995 | No Change   |
| 1996 | No Change   |
| 1997 | No Change   |
| 1998 | No Change   |
| 1999 | No Change   |
| 2000 | No Change   |

V-303  
17  
V-3  
17

| No. | Owner              | Section        | Instrument | Date         | Record                     | Remarks  |
|-----|--------------------|----------------|------------|--------------|----------------------------|--|
| 1   | S. S. Ward         | John T. Adams  | W. Deed    | Dec 31, 1897 | DB 736 1486 Apr 27, 1901   | 2600' case Note No. 1 This is a part of parcel 27, Map 1 |
| 2   | Wm. A. Adams       | John T. Adams  | W. Deed    | Dec 1, 1897  | DB 736 2028 Apr 16, 1901   | 2600' case Note No. 1                                    |
| 3   | John T. Adams      | John T. Adams  | W. Deed    | Dec 17, 1897 | DB 736 1486 Apr 27, 1901   | 2600' case Note No. 1 Part of this parcel                |
| 4   | John T. Adams      | John T. Adams  | W. Deed    | Dec 17, 1897 | DB 736 1486 Apr 27, 1901   | 2600' case Note No. 1 Part of this parcel                |
| 5   | F. D. A. Thompson  | T. A. C. Ry Co | W. Deed    | May 4, 1907  | DB 7106 1194 June 6, 1907  | 2600' case Note No. 1                                    |
| 6   | Frank Gillenwaters | T. A. C. Ry Co | W. Deed    | Jan 25, 1907 | DB 7106 1196 June 6, 1907  | 2600' case Note No. 1                                    |
| 7   | State of Ohio      | John T. Adams  | W. Deed    | Feb 16, 1899 | Land and Tax Dept File     | 2600' case Note No. 1 Part of this parcel                |
| 8   | Allen Ranck        | John T. Adams  | W. Deed    | Dec 17, 1897 | DB 736 1442 Apr 24, 1901   | 2600' case Note No. 1 Part of this parcel                |
| 9   | J. B. Popker, Jr.  | T. A. C. Ry Co | W. Deed    | Apr 14, 1909 | DB 7107 1546 June 24, 1909 | 1600' case Note No. 1                                    |
| 10  | Geo. H. Warrington | T. A. C. Ry Co | W. Deed    | Sept 7, 1907 | DB 7107 1548 June 24, 1909 | 1600' case Note No. 1                                    |
| 11  | John R. Warrington | T. A. C. Ry Co | W. Deed    | Sept 7, 1907 | DB 7107 1548 June 24, 1909 | 1600' case Note No. 1                                    |
| 12  | John R. Warrington | T. A. C. Ry Co | W. Deed    | Sept 7, 1907 | DB 7107 1548 June 24, 1909 | 1600' case Note No. 1                                    |
| 13  | John R. Warrington | T. A. C. Ry Co | W. Deed    | Sept 7, 1907 | DB 7107 1548 June 24, 1909 | 1600' case Note No. 1                                    |
| 14  | John R. Warrington | T. A. C. Ry Co | W. Deed    | Sept 7, 1907 | DB 7107 1548 June 24, 1909 | 1600' case Note No. 1                                    |
| 15  | John R. Warrington | T. A. C. Ry Co | W. Deed    | Sept 7, 1907 | DB 7107 1548 June 24, 1909 | 1600' case Note No. 1                                    |
| 16  | John R. Warrington | T. A. C. Ry Co | W. Deed    | Sept 7, 1907 | DB 7107 1548 June 24, 1909 | 1600' case Note No. 1                                    |
| 17  | John R. Warrington | T. A. C. Ry Co | W. Deed    | Sept 7, 1907 | DB 7107 1548 June 24, 1909 | 1600' case Note No. 1                                    |
| 18  | John R. Warrington | T. A. C. Ry Co | W. Deed    | Sept 7, 1907 | DB 7107 1548 June 24, 1909 | 1600' case Note No. 1                                    |
| 19  | John R. Warrington | T. A. C. Ry Co | W. Deed    | Sept 7, 1907 | DB 7107 1548 June 24, 1909 | 1600' case Note No. 1                                    |
| 20  | John R. Warrington | T. A. C. Ry Co | W. Deed    | Sept 7, 1907 | DB 7107 1548 June 24, 1909 | 1600' case Note No. 1                                    |



| No. | Grantee             | Grantor       | Instrument | Date        | Record | Cost No. | Remarks   |
|-----|---------------------|---------------|------------|-------------|--------|----------|-----------|
| 4A  | T&O.C.R. Co ANYCRRC | STATE OF OHIO | PERM EASE  | Nov 7, 1946 |        | 262      | AFE 66370 |
| 7A  | do                  | do            | do         | do          | do     | 262      | do        |
| 8A  | do                  | do            | do         | do          | do     | 262      | do        |
| 9A  | do                  | do            | do         | do          | do     | 262      | do        |
| 10A | do                  | do            | do         | do          | do     | 262      | do        |
| 12A | do                  | do            | do         | do          | do     | 262      | do        |
| 13A | do                  | do            | do         | do          | do     | 262      | do        |
| 14A | do                  | do            | do         | do          | do     | 262      | do        |

OWNER VALUATION SUB SHEET REAL ESTATE REGION  
 300 3030 0 18

| REVISED        | REVIEWED       |
|----------------|----------------|
| 1941 6-1-40    | 1918 No Change |
| 1946 No Change | 1919 No Change |
| 1949 do        | 1920 No Change |
| 1950 do        | 1921 No Change |
| 1951 do        | 1922 No Change |
| 1952 3-8-54    | 1923 No Change |
| 1953 No Change | 1924 No Change |
| 1954 do        | 1925 No Change |
| 1955 do        | 1926 No Change |
| 1956 do        | 1927 No Change |
| 1957 do        | 1928 No Change |
| 1958 do        | 1929 No Change |
| 1959 3-8-60    | 1930 No Change |
| 1960-61 1-8-61 | 1931 No Change |

Note: No. 1 - Conveyed to T. A. C. Ry Co by John T. Adams by W. Deed Feb 16, 1899 Recorded Vol. 1486 Apr 27, 1901

DETAIL OF PROPERTY. Scale 1"=100'

THIS TRACING IS 50% ORIGINAL SIZE. DRAFTSMAN TO DOUBLE SCALE.

# THIS PROPERTY WAS HERETOFORE THE PROPERTY OF THE NEW YORK CENTRAL RAILROAD COMPANY, JUNE 30, 1932. ANNOUNCED IN I. C. C. BULLETIN NO. 17700 RECORDED JUNE 16, 1932. RIGHT OF WAY AND TRACK MAP. OPERATED BY THE TOLEDO AND OHIO CENTRAL RAILWAY COMPANY.

ST. MARYS BRANCH -- MAIN LINE FROM STATION 1600+00 TO STATION 1700+35.2 SCALE 1 INCH = 200 FEET JUNE 30, 1918

OFFICE OF VALUATION ENGINEER, COLUMBUS, OHIO. CONDUCTED AS OF JAN. 1, 1918. OFFICE OF VALUATION ENGINEER, COLUMBUS, OHIO. CONDUCTED AS OF JAN. 1, 1918. PREPARED BY THE NEW YORK CENTRAL RAILROAD COMPANY SUBSEQUENT TO DECEMBER 31, 1917.

V-303 18 V-3 18

INDEXED ON MAP 6216 14P-6

18.42 AC. THIS SHEET

18.42

AYS-R.O.W-F= 17.82 AC.

A = 18,730 #  
B = 7,200 #

| OWNER | VALUATION | SUB | SHEET | REAL ESTATE |
|-------|-----------|-----|-------|-------------|
| 580   | 3030      |     | 19    | REGION      |

THIS TRACING IS 50% ORIGINAL SIZE. DRAFTSMAN TO DOUBLE SCALE

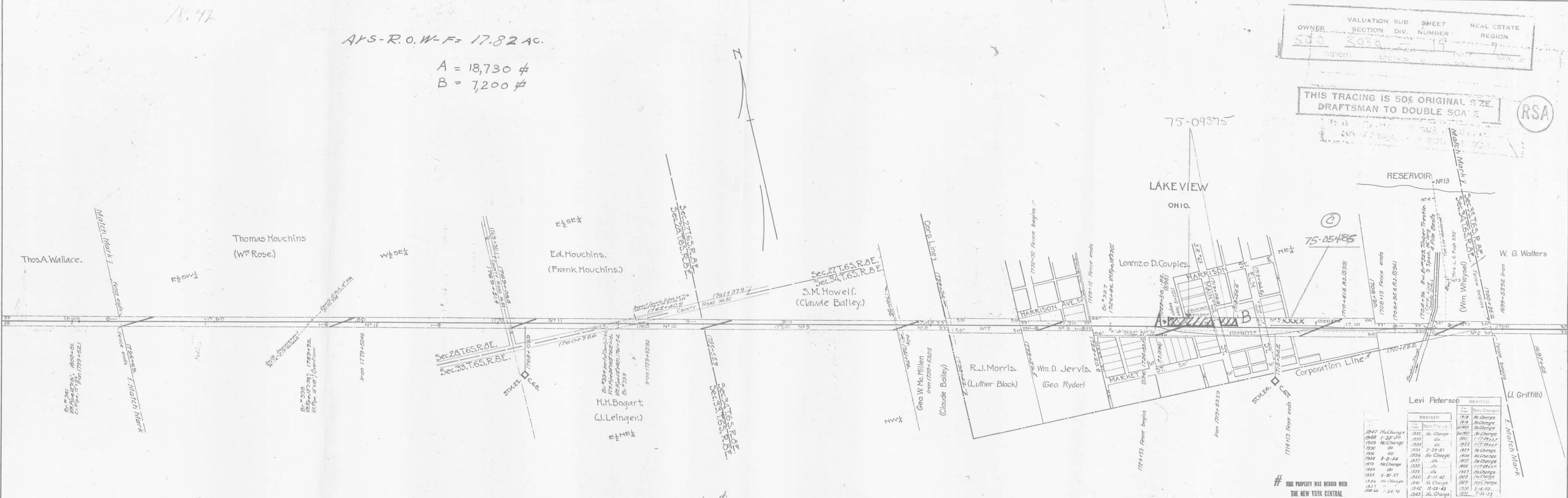

| No. | Grantor              | Grantee           | Instrument | Date          | Record                    | Cont. No. | Remarks   |
|-----|----------------------|-------------------|------------|---------------|---------------------------|-----------|---|
| 1   | W. G. Walters, et al | John T. Adams     | W. Deed    | Oct 30, 1897  | DB V95 P459 Apr 27, 1901  | 161920    | This is a part of parcel #19, Map 16                              |
| 2   | Levi Peterson        | John T. Adams     | W. Deed    | Dec 17, 1897  | DB V95 P459 Apr 23, 1901  | 161920    | See Note No. 1  |
| 3   | Mrs. L. C. Pugh      | T & O C Ry Co     | Agreement  | Feb 17, 1902  | Land and Tax Dept File    | 168120    | Right to lay 330' of pipe (water) line                            |
| 4   | Mrs. Jane Love       | T & O C Ry Co     | Agreement  | Feb 17, 1902  | Land and Tax Dept File    | 168220    | Right to lay 640' of pipe (water) line                            |
| 5   | Lorenzo D. Couples   | John T. Adams     | W. Deed    | Dec 17, 1897  | DB V95 P404 Apr 17, 1901  | 161870    | See Note No. 1  |
| 6   | Wm. D. Jervis        | John T. Adams     | W. Deed    | Dec 17, 1897  | DB V95 P421 Apr 19, 1901  | 162420    | See Note No. 1  |
| 7   | R. J. Morris         | T & O C Ry Co     | W. Deed    | Apr 10, 1902  | DB V96 P607 July 12, 1902 | 163820    | See Note No. 1  |
| 8   | Geo. W. Millen       | John T. Adams     | W. Deed    | Dec 17, 1897  | DB V95 P426 Apr 22, 1901  | 162620    | See Note No. 1  |
| 9   | Wm. H. Howell        | John T. Adams     | W. Deed    | Dec 30, 1897  | DB V95 P460 Apr 19, 1901  | 162720    | See Note No. 1  |
| 10  | Henry E. Siefert     | John T. Adams     | W. Deed    | Dec 17, 1897  | DB V95 P403 Apr 17, 1901  | 161870    | See Note No. 1  |
| 11  | Edw. M. Houchins     | John T. Adams     | W. Deed    | Jan 19, 1898  | DB V95 P419 Apr 19, 1901  | 162820    | See Note No. 1  |
| 12  | Thos. Houchins       | John T. Adams     | W. Deed    | Jan 10, 1898  | DB V95 P419 Apr 19, 1901  | 162820    | See Note No. 1  |
| 13  | State of Ohio        | N.Y.C. & O.R. Co. | Agreement  | Feb. 16, 1923 | Land and Tax Dept. File   | 143       | Right to construct three inch water pipe line. Comp. Report 34-H. |

A. OH. 0 # # # # H 5-9 = 18,400 # = \$2200  
 B- " " H 6-2 = 11,960 # = \$1,435  
 C- " " L 5-4  
 F " " M 4-3

LOGAN COUNTY  
STOKES TOWNSHIP

| Year | Date      | Change | Value     |
|------|-----------|--------|-----------|
| 1847 | No Change | 1832   | No Change |
| 1848 | 1-25-50   | 1834   | do        |
| 1849 | No Change | 1835   | do        |
| 1850 | do        | 1836   | do        |
| 1851 | do        | 1837   | do        |
| 1852 | 3-8-54    | 1838   | No Change |
| 1853 | do        | 1839   | do        |
| 1854 | do        | 1840   | do        |
| 1855 | 5-20-57   | 1841   | No Change |
| 1856 | No Change | 1842   | do        |
| 1857 | do        | 1843   | No Change |
| 1858 | 1-24-70   | 1844   | do        |
| 1859 | do        | 1845   | do        |
| 1860 | do        | 1846   | do        |

# THIS PROPERTY WAS HEARD WITH THE NEW YORK CENTRAL RAILROAD COMPANY  
 AUTHORIZED BY L. C. Docket No. 17700  
 DECEMBER 10, 1922

RIGHT OF WAY AND TRACK MAP  
 # THE TOLEDO AND OHIO CENTRAL RAILWAY  
 OPERATED BY \*  
 THE TOLEDO AND OHIO CENTRAL RAILWAY COMPANY

ST. MARYS BRANCH -- MAIN LINE  
 FROM STATION 1700+35.2 TO STATION 1796+69.  
 SCALE 1 INCH = 200 FEET  
 OFFICE OF VALUATION ENGINEER, COLUMBUS, OHIO.  
 CORRECTED AS OF JAN. 1, 1921  
 OFFICE OF VALUATION ENGINEER, CLEVELAND, OHIO  
 OPERATED BY THE NEW YORK CENTRAL RAILROAD COMPANY SUBSEQUENT TO DECEMBER 31, 1921

V-303  
19

V-3  
19

INDEXED ON MAP  
4216 HP-7

18.26 AC

AVS-R.O.W-F = 18.28 AC.

VALUATION SHEET REAL ESTATE REGION  
 OWNER: 570 SECTION: 3030 NUMBER: 0 REGION: 20

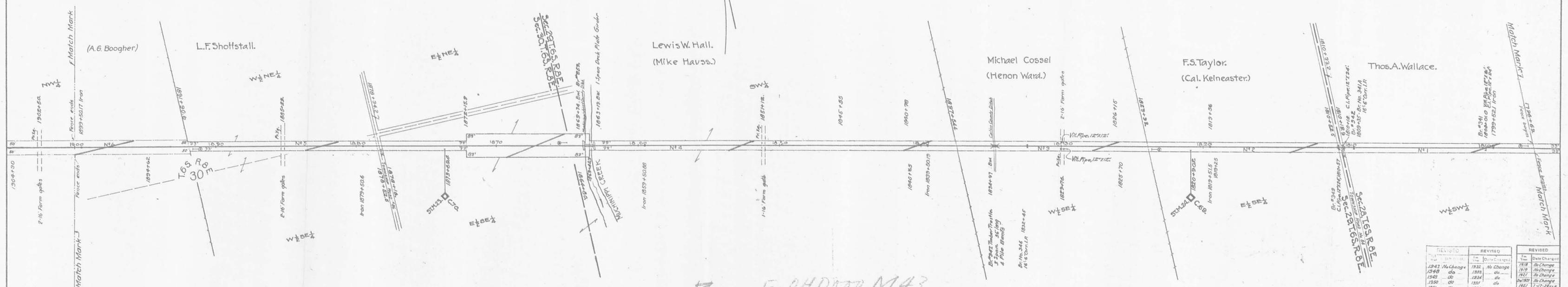

F.04D000 M43

**SCHEDULE OF PROPERTY**

| No. | Grantor               | Grantee   | Instrument | Date         | Record | Cont. No. | Remarks   |
|-----|-----------------------|---|------------|--------------|--------|-----------|---|
| 1   | T. A. Wallace         | John F. Adams                                   | W. Deed    | Jan 10, 1898 | DB 796 | 1458      | Apr 27, 1901  |
| 2   | Frederick S. Taylor   | T & O C Ry Co                                   | W. Deed    | Dec 29, 1901 | DB 796 | 1316      | Feb 4, 1902   |
| 3   | Michael Cossel        | T & O C Ry Co                                   | W. Deed    | Apr 19, 1901 | DB 796 | 1664      | June 18, 1901                                       |
| 4   | Lewis W. Hall, et al  | John F. Adams                                   | W. Deed    | Jan 17, 1898 | DB 796 | 1418      | Feb 19, 1901  |
| 5   | L. F. Shoffstall      | T & O C Ry Co                                   | W. Deed    | Apr 19, 1901 | DB 796 | 1667      | June 17, 1901                                       |
| 6   | No paper title found. | Held by adverse possession and claimed by Ry Co |            |              |        | 2859228/W | excepted in transfer of contiguous land DB 796 1458 |

Note:-  
 No. 1 - Conveyed to D & L E Ry Co by John F. Adams by G.C. Deed Feb 18, 1899. Recorded Vol. 96 1460 Apr 29, 1901. Cont. No. 1317

LOGAN COUNTY  
 STOKES TOWNSHIP

THIS TRACING IS 50% ORIGINAL SIZE.  
 DRAFTSMAN TO DOUBLE SCALE

SHEET NO. 21 OF 24 OF THE TOLEDO AND OHIO CENTRAL RAILROAD.  
 BY HEATS BRANCH - MAIN LINE.  
 FROM SURVEY STATION 1750+65. TO SURVEY STATION 1900+00.  
 Valuation Engineer

| REVISED | REVISED      | REVISED      |           |
|---------|--------------|--------------|-----------|
| Year    | Date Changed | Date Changed |           |
| 1941    | No Change    | 1932         | No Change |
| 1940    | do           | 1933         | do        |
| 1939    | do           | 1934         | do        |
| 1938    | do           | 1935         | do        |
| 1937    | do           | 1936         | do        |
| 1936    | do           | 1937         | do        |
| 1935    | do           | 1938         | do        |
| 1934    | do           | 1939         | do        |
| 1933    | do           | 1940         | do        |
| 1932    | do           | 1941         | do        |
| 1931    | do           | 1942         | do        |
| 1930    | do           | 1943         | do        |
| 1929    | do           | 1944         | do        |
| 1928    | do           | 1945         | do        |
| 1927    | do           | 1946         | do        |
| 1926    | do           | 1947         | do        |
| 1925    | do           | 1948         | do        |
| 1924    | do           | 1949         | do        |
| 1923    | do           | 1950         | do        |
| 1922    | do           | 1951         | do        |
| 1921    | do           | 1952         | do        |
| 1920    | do           | 1953         | do        |
| 1919    | do           | 1954         | do        |
| 1918    | do           | 1955         | do        |
| 1917    | do           | 1956         | do        |
| 1916    | do           | 1957         | do        |
| 1915    | do           | 1958         | do        |
| 1914    | do           | 1959         | do        |
| 1913    | do           | 1960         | do        |
| 1912    | do           | 1961         | do        |
| 1911    | do           | 1962         | do        |
| 1910    | do           | 1963         | do        |
| 1909    | do           | 1964         | do        |
| 1908    | do           | 1965         | do        |
| 1907    | do           | 1966         | do        |
| 1906    | do           | 1967         | do        |
| 1905    | do           | 1968         | do        |
| 1904    | do           | 1969         | do        |
| 1903    | do           | 1970         | do        |
| 1902    | do           | 1971         | do        |
| 1901    | do           | 1972         | do        |
| 1900    | do           | 1973         | do        |
| 1899    | do           | 1974         | do        |
| 1898    | do           | 1975         | do        |
| 1897    | do           | 1976         | do        |
| 1896    | do           | 1977         | do        |
| 1895    | do           | 1978         | do        |
| 1894    | do           | 1979         | do        |
| 1893    | do           | 1980         | do        |
| 1892    | do           | 1981         | do        |
| 1891    | do           | 1982         | do        |
| 1890    | do           | 1983         | do        |
| 1889    | do           | 1984         | do        |
| 1888    | do           | 1985         | do        |
| 1887    | do           | 1986         | do        |
| 1886    | do           | 1987         | do        |
| 1885    | do           | 1988         | do        |
| 1884    | do           | 1989         | do        |
| 1883    | do           | 1990         | do        |
| 1882    | do           | 1991         | do        |
| 1881    | do           | 1992         | do        |
| 1880    | do           | 1993         | do        |
| 1879    | do           | 1994         | do        |
| 1878    | do           | 1995         | do        |
| 1877    | do           | 1996         | do        |
| 1876    | do           | 1997         | do        |
| 1875    | do           | 1998         | do        |
| 1874    | do           | 1999         | do        |
| 1873    | do           | 2000         | do        |

# THIS PROPERTY WAS MERGED WITH  
 THE NEW YORK CENTRAL  
 RAILROAD COMPANY  
 JUNE 30, 1952  
 AUTHORIZED BY I. C. C. Docket No. 17700  
 ORDERED JUNE 10, 1952

RIGHT OF WAY AND TRACK MAP  
 # THE TOLEDO AND OHIO CENTRAL RAILWAY  
 OPERATED BY \*  
 THE TOLEDO AND OHIO CENTRAL RAILWAY COMPANY

ST. MARYS BRANCH -- MAIN LINE  
 FROM STATION 1750+65. TO STATION 1900+00  
 SCALE 1 INCH = 200 FEET  
 JUNE 30, 1918

OFFICE OF VALUATION ENGINEER, COLUMBUS, OHIO.  
 CORRECTED AS OF JAN. 1, 1921  
 OFFICE OF VALUATION ENGINEER, CLEVELAND, OHIO  
 \* OPERATED BY THE NEW YORK CENTRAL RAILROAD COMPANY SUBSEQUENT TO DECEMBER 31, 1921.

INDEXED ON MAP  
 6216 1470

AVS - R. O. W - F = 17.03 AC.

VALUATION SHEET  
OWNER: 500  
SECTION: 3030  
DIV. NUMBER: 21  
REGION: 7

THIS TRACING IS 50% ORIGINAL SIZE  
DRAFTSMAN TO DOUBLE SCALE

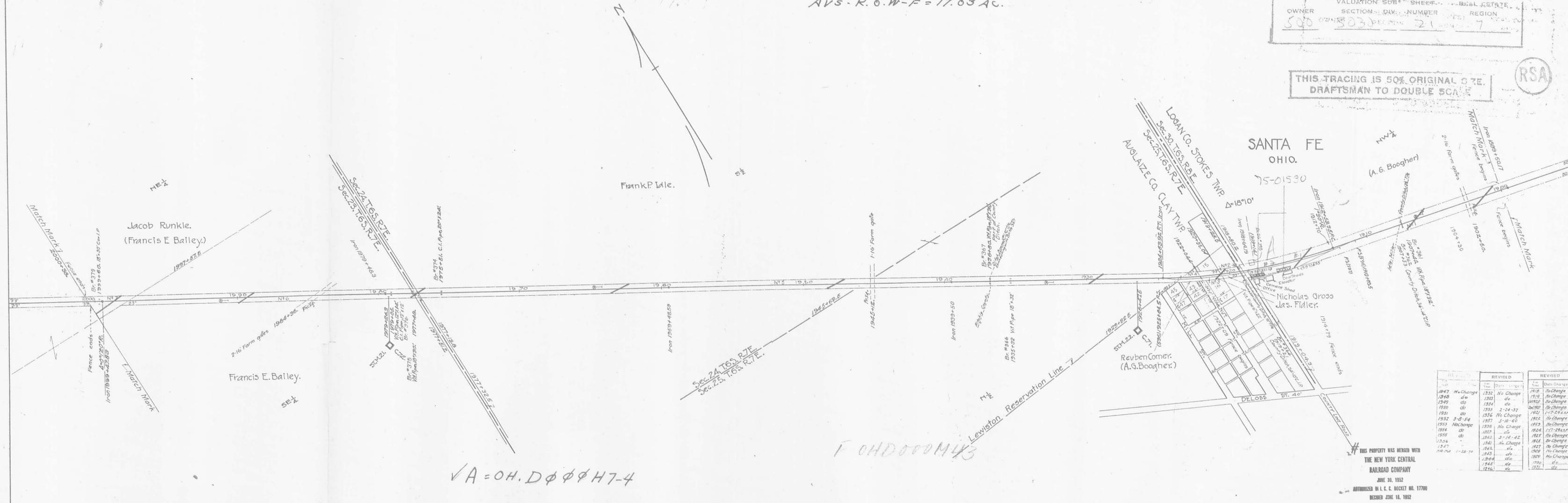

| REVISION       | REVISION       | REVISION       |
|----------------|----------------|----------------|
| 1897 No Change | 1922 No Change | 1910 No Change |
| 1940 do        | 1923 do        | 1910 No Change |
| 1949 do        | 1924 do        | 1910 No Change |
| 1950 do        | 1925 2-24-37   | 1910 No Change |
| 1951 do        | 1926           | 1910 No Change |
| 1952 3-8-54    | 1926 No Change | 1912 No Change |
| 1953 No Change | 1926 No Change | 1923 No Change |
| 1954 do        | 1927 3-10-45   | 1924 127-24-55 |
| 1955 do        | 1928 3-18-42   | 1925 No Change |
| 1956 do        | 1929           | 1926 No Change |
| 1957 do        | 1930           | 1927 No Change |
| 1958 do        | 1931           | 1928 No Change |
| 1959 do        | 1932           | 1929 No Change |
| 1960 do        | 1933           | 1930 do        |
| 1961 do        | 1934           | 1931 do        |
| 1962 do        | 1935           | 1932 do        |

SCHEDULE OF PROPERTY

| No | Grantor               | Grantee   | Instrument | Date         | Record                         | Dist. No.   | Remarks                                     |
|----|-----------------------|---|------------|--------------|--------------------------------|---|---|
| 1  | No paper title found. | Held by adverse possession and claimed by Ry Co |            |              |                                | 3489720 R/W exempted in transfer of con- (LOGAN COUNTY) |   |
| 2  | Nicholas Gross        | John T. Adams                                   | W. Deed    | Dec 20, 1897 | DB V74 P189 Apr 8, 1901 1656 3 |   | Trigons land, DB V94 P486 (AUGLAIZE COUNTY) |
| 3  | Jas. Fidler           | John T. Adams                                   | W. Deed    | Dec 20, 1897 | DB V74 P190 Apr 8, 1901 1659 4 |   | See Note No. 2                              |
| 4  | Reuben Comer          | John T. Adams                                   | W. Deed    | Dec 20, 1897 | DB V74 P191 Apr 8, 1901 1660 5 |   | See Note No. 2                              |
| 5  | F. E. Idle            | John T. Adams                                   | W. Deed    | Jan 18, 1898 | DB V74 P187 Apr 8, 1901 1643 6 |   | See Note No. 1                              |
| 6  | Francis E. Bailey     | John T. Adams                                   | W. Deed    | Jan 7, 1899  | DB V74 P193 Apr 8, 1901 1648 7 |   | See Note No. 2                              |
| 7  | Jacob Runkle          | John T. Adams                                   | W. Deed    | Dec 20, 1897 | DB V74 P194 Apr 8, 1901 1648 8 |   | See Note No. 2                              |

Notes:-  
 No. 1 - Conveyed to T & O C Ry Co by John T. Adams by G. C. Deed Feb 22, 1901. Recorded Vol. 73 P246 Apr 8, 1901. Dist. No. 1844  
 No. 2 - Conveyed to D & L N Ry Co by John T. Adams by G. C. Deed Feb 10, 1899. Recorded Vol. 73 P248 Apr 8, 1901. Dist. No. 1848

AUGLAIZE COUNTY CLAY TOWNSHIP  
LOGAN COUNTY STOKES TOWNSHIP

RIGHT OF WAY AND TRACK MAP  
# THE TOLEDO AND OHIO CENTRAL RAILWAY  
OPERATED BY  
THE TOLEDO AND OHIO CENTRAL RAILWAY COMPANY

ST. MARYS BRANCH -- MAIN LINE  
FROM STATION 1900+00 TO STATION 2000+38  
SCALE 1 INCH = 200 FEET  
JUNE 30, 1916  
OFFICE OF VALUATION ENGINEER, COLUMBUS, OHIO.  
CORRECTED AS OF JAN. 1, 1931  
OFFICE OF VALUATION ENGINEER, CLEVELAND, OHIO  
OPERATED BY THE NEW YORK CENTRAL RAILROAD COMPANY SUBSEQUENT TO DECEMBER 31, 1921.

INDEXED ON MAP  
6216 4P-9

303-11  
A44-3-5

V6-Pis-F1

All those parcels of land located at Bellefontaine, situate in the Township of Lake, County of Logan, State of Ohio, being part of Northwest 1/4, Southwest 1/4 and Southeast 1/4 of Section 33, Township 4, Range 14, and being designated Parcel Nos. OH D09 005-1 and OH D09 006-3 on Railroad Valuation Map Nos. 072-5420-0-S-25b-7, as revised to March 7, 1967 and 072-5420-0-ST25-26-7, as revised to March 7, 1967, and being all of the land of The Cleveland, Cincinnati, Chicago and St. Louis Railway Company, as shown on the Map, which lies southerly of Lake Avenue and northerly of Allen Road and westerly of the following described line:

Beginning at a point on the southerly line of Lake Avenue (Silver Lake Pike), distant 40 feet measured westwardly and radially from the centerline of Track No. 223 of said Railway Company, as it was located November 21, 1975;

Thence, extending southwardly and parallel to said centerline 5375 feet, more or less, to a point on the northerly line of Allen Road, the point of ending;

The above described parcel or parcels are identified in the records of the United States Railway Association as Line Code 8231-99-100.

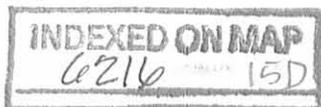







Logan County

Penn Central Transportation Company

Situate in the above named County, State of Ohio, being all of the property of the above named Company's line of railroad known as St. Marys Branch; further identified by Line Code 8142; and described as follows;

This part of the line of railroad enters the County at or near 300 feet, more or less, westerly of O.H. Bridge No. 73A west of east Liberty in Perry Township; extending westwardly to a point 2400 feet, more or less, southeasterly of the Mad River in Zanesfield, Jefferson Township.

Refer to Map Nos:

500-3030-0-4-7

thru

500-3030-0-7-7

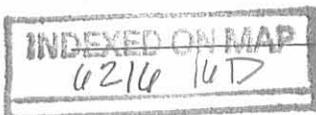

| OWNER   | VALUATION | SUB    | SHEET  | REAL ESTATE |
|---------|-----------|--------|--------|-------------|
| 500     | 3030      | -      | 4      | 7           |
| SECTION | DIV.      | NUMBER | REGION |             |

THIS TRACING IS 50% ORIGINAL SIZE.  
DRAFTSMAN TO DOUBLE SIZE.



AB-R.O.M-B = 1.16 AC.  
31.30 AC. TOTAL

B-DHD100M155

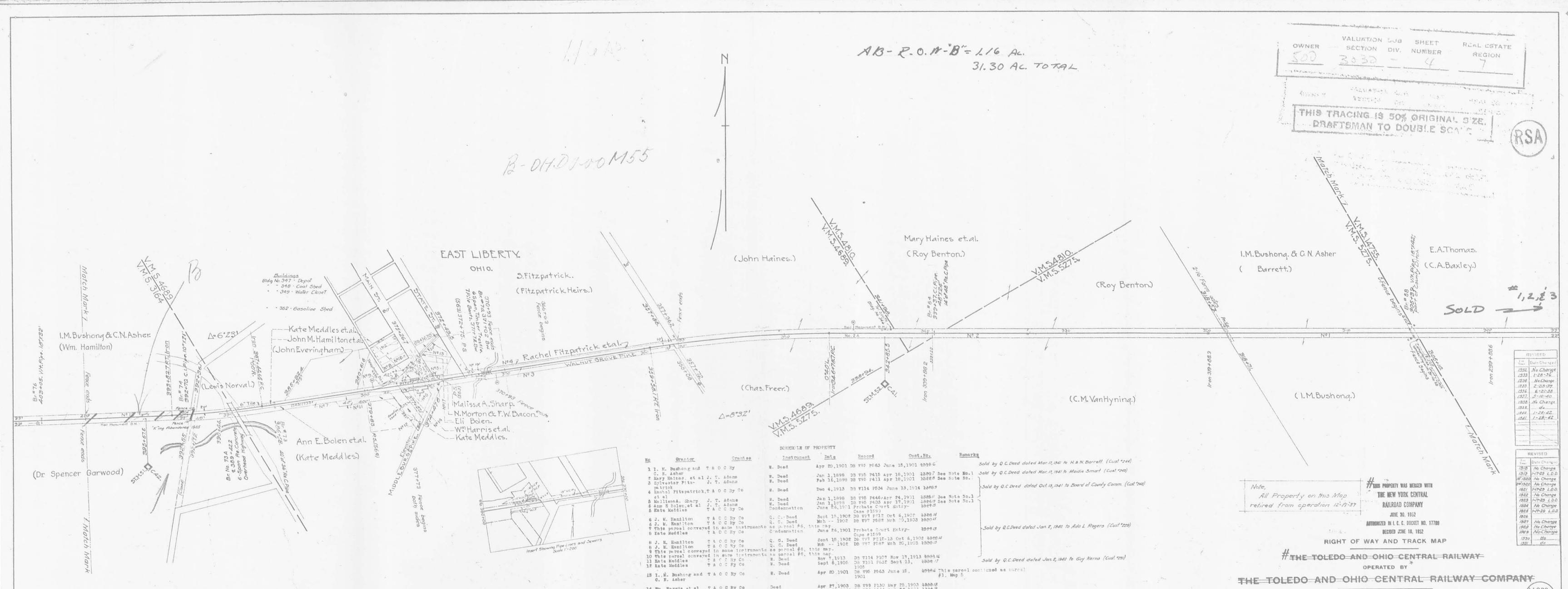

SCHEDULE OF PROPERTY

| No. | Grantor                       | Grantee       | Instrument | Date          | Record              | Cont. No.            | Remarks  |
|-----|-------------------------------|---------------|------------|---------------|---------------------|----------------------|--|
| 1   | I. M. Bushong and C. N. Asher | T & O C Ry    | W. Deed    | Apr 20, 1901  | DB 792 P663         | June 15, 1901 4226 G | Sold by Q.C. Deed dated Mar. 17, 1941 to H. & N. Barrett. (Cost \$24)      |
| 2   | C. N. Asher                   | T & O C Ry    | W. Deed    | Jan 1, 1898   | DB 795 P415         | Apr 16, 1901 4280 F  | Sold by Q.C. Deed dated Mar. 17, 1941 to Madie Smart. (Cost \$24)          |
| 3   | Mary Haines et al             | J. T. Adams   | W. Deed    | Feb 16, 1898  | DB 795 P411         | Apr 16, 1901 4280 F  | Sold by Q.C. Deed dated Oct. 13, 1941 to Board of County Comm. (Cost \$24) |
| 4   | Sylvester Fitzpatrick         | J. T. Adams   | W. Deed    | Dec 4, 1913   | DB 714 P534         | June 13, 1914 4295 F |  |
| 5   | Rachel Fitzpatrick et al      | T & O C Ry Co | W. Deed    | Jan 1, 1898   | DB 795 P446         | Apr 24, 1901 4280 F  |  |
| 6   | Malissa A. Sharp              | J. T. Adams   | W. Deed    | Jan 1, 1898   | DB 795 P403         | Apr 17, 1901 4280 F  |  |
| 7   | Ann E. Bolen et al            | J. T. Adams   | W. Deed    | June 16, 1901 | Probate Court Entry | Case #1599           |  |
| 8   | J. M. Hamilton                | T & O C Ry Co | Q. C. Deed | Sept 15, 1902 | DB 797 P511         | Oct 6, 1902 4280 F   |  |
| 9   | J. M. Hamilton                | T & O C Ry Co | Q. C. Deed | Mar 1, 1902   | DB 797 P508         | Mar 20, 1902 4280 F  |  |
| 10  | Ann E. Bolen et al            | T & O C Ry Co | Q. C. Deed | June 26, 1901 | Probate Court Entry | Case #1599           |  |
| 11  | J. M. Hamilton                | T & O C Ry Co | Q. C. Deed | Sept 16, 1902 | DB 797 P512         | Oct 6, 1902 4280 F   |  |
| 12  | J. M. Hamilton                | T & O C Ry Co | Q. C. Deed | Mar 1, 1902   | DB 797 P508         | Mar 20, 1902 4280 F  |  |
| 13  | Ann E. Bolen et al            | T & O C Ry Co | Q. C. Deed | June 26, 1901 | Probate Court Entry | Case #1599           |  |
| 14  | I. M. Bushong and C. N. Asher | T & O C Ry Co | W. Deed    | Apr 20, 1901  | DB 792 P663         | June 15, 1901 4226 G |  |
| 15  | H. & N. Barrett et al         | T & O C Ry Co | W. Deed    | Apr 27, 1903  | DB 799 P130         | May 25, 1903 4280 F  |  |
| 16  | E. Barton et al               | T & O C Ry Co | W. Deed    | July 31, 1901 | DB 796 P164         | Aug 27, 1901 4280 F  |  |
| 17  | Logan County Commissioners    | T & O C Ry Co | W. Deed    | July 26, 1901 |                     |                      |  |
| 18  | Eli Bolen                     | T & O C Ry Co | W. Deed    | July 31, 1901 | DB 796 P164         | Aug 27, 1901 4280 F  |  |
| 19  | Eli Bolen                     | T & O C Ry Co | W. Deed    | July 31, 1901 | DB 796 P164         | Aug 27, 1901 4280 F  |  |
| 20  | T. A. C. Ry Co                | Minne Cole    | Q. C. Deed | Mar 18, 1941  |                     | 265                  |  |

Note:  
All Property on this Map  
retired from operation 12-17-37

THIS PROPERTY WAS MERGED WITH  
THE NEW YORK CENTRAL  
RAILROAD COMPANY  
JUNE 30, 1912  
AUTHORIZED IN I. C. C. Docket No. 17700  
DECIDED JUNE 16, 1912

RIGHT OF WAY AND TRACK MAP  
OPERATED BY  
THE TOLEDO AND OHIO CENTRAL RAILWAY COMPANY

ST. MARYS BRANCH -- MAIN LINE  
FROM STATION 305+10. TO STATION 400+00  
SCALE 1 INCH = 200 FEET  
JUNE 30, 1912

OFFICE OF VALUATION ENGINEER, COLUMBUS, OHIO.  
OPERATED BY THE NEW YORK CENTRAL RAILROAD  
COMPANY SUBSEQUENT TO DECEMBER 31, 1921.

CORRECTED AS OF JAN. 1 1921  
OFFICE OF VALUATION ENGINEER, CLEVELAND, OHIO

REVISED

| Date | Description |
|------|-------------|
| 1232 | No Change   |
| 1233 | 1-28-36     |
| 1234 | No Change   |
| 1235 | 2-23-37     |
| 1236 | 6-22-38     |
| 1237 | 5-10-40     |
| 1238 | No Change   |
| 1239 | 1-28-42     |
| 1240 | 1-28-42     |

REVISED

| Date | Description |
|------|-------------|
| 1241 | No Change   |
| 1242 | 1-28-42     |
| 1243 | 1-28-42     |
| 1244 | No Change   |
| 1245 | 1-28-42     |
| 1246 | No Change   |
| 1247 | No Change   |
| 1248 | No Change   |
| 1249 | No Change   |
| 1250 | No Change   |

V-303  
4

V-3  
4

INDEXED ON MAP  
6216 16P1

|                                 |               |        |           |           |
|---------------------------------|---------------|--------|-----------|-----------|
| VALUATION SUB SHEET REAL ESTATE |               |        |           |           |
| OWNER: 500                      | SECTION: 3030 | DIV: 5 | NUMBER: 7 | REGION: 7 |

THIS TRACING IS 50% ORIGINAL SIZE.  
DRAFTSMAN TO DOUBLE SCALE



AB-R.O.W.-B=15.15

15.15 AC

B-DHD000 M55

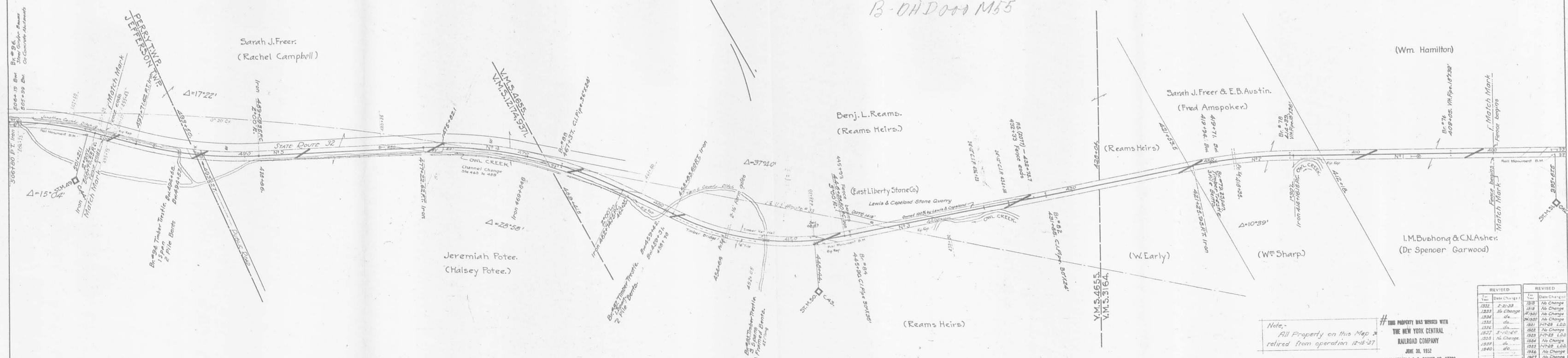

SCHEDULE OF PROPERTY

| No | Grantor                         | Grantee       | Instrument | Date         | Record      | Cont. No.             | Remarks                                   |
|----|---------------------------------|---------------|------------|--------------|-------------|-----------------------|---|
| 1  | I. M. Bushong and C. N. Asher   | T & O C Ry Co | W. Deed    | Apr 20, 1901 | DB 796 P668 | June 16, 1901 3610    | This is a part of parcel #13 Map 4        |
| 2  | Sarah J. Freer and E. B. Austin | T & O C Ry Co | W. Deed    | Apr 20, 1901 | DB 796 P665 | June 16, 1901 4884 Z2 |   |
| 3  | Benj. L. Reams                  | T & O C Ry Co | W. Deed    | Aug 26, 1901 | DB 796 P671 | Sept 23, 1901 3884 Z3 |   |
| 4  | Jeremiah Potee, et al           | T & O C Ry Co | W. Deed    | Apr 26, 1901 | DB 796 P670 | Sept 23, 1901 3440 Z4 |   |
| 5  | Sarah J. Freer                  | T & O C Ry Co | W. Deed    | April- 1901  | DB 796 P664 | June 16, 1901 4842    | This parcel continued as parcel #1, Map C |

LOGAN COUNTY  
PERRY TOWNSHIP  
JEFFERSON TOWNSHIP

Note: All Property on this Map retired from operation 12-15-37

# THIS PROPERTY WAS SURVEYED WITH THE NEW YORK CENTRAL RAILROAD COMPANY  
JUNE 30, 1932  
AUTHORIZED BY L. C. C. CHECKET NO. 17700  
DECEMBER 12, 1932

| REVISED | REVISED      |
|---------|--------------|
| Year    | Date Changed |
| 1932    | 2-21-38      |
| 1933    | No Change    |
| 1934    | No Change    |
| 1935    | No Change    |
| 1936    | No Change    |
| 1937    | No Change    |
| 1938    | No Change    |
| 1939    | No Change    |
| 1940    | No Change    |
| 1941    | No Change    |
| 1942    | No Change    |
| 1943    | No Change    |
| 1944    | No Change    |
| 1945    | No Change    |
| 1946    | No Change    |
| 1947    | No Change    |
| 1948    | No Change    |
| 1949    | No Change    |
| 1950    | No Change    |
| 1951    | No Change    |
| 1952    | No Change    |

RIGHT OF WAY AND TRACK MAP  
# THE TOLEDO AND OHIO CENTRAL RAILWAY  
OPERATED BY  
THE TOLEDO AND OHIO CENTRAL RAILWAY COMPANY

ST. MARYS BRANCH -- MAIN LINE  
FROM STATION 400+00 TO STATION 500+00  
SCALE 1 INCH = 200 FEET  
JUNE 30, 1918  
OFFICE OF VALUATION ENGINEER, COLUMBUS, OHIO.  
\* OPERATED BY THE NEW YORK CENTRAL RAILROAD COMPANY SUBSEQUENT TO DECEMBER 31, 1921.

V-303  
5  
V-3  
5

INDEXED ON MAP  
6210 168-2

AB-R.O.W-B-12.30 AC.

12.30

| OWNER | VALUATION SECTION | SUB DIV. NUMBER | SHEET NUMBER | REAL ESTATE REGION |
|-------|-------------------|-----------------|--------------|--------------------|
| 500   | 3030              | 6               |              |                    |

THIS TRACING IS 50% ORIGINAL SIZE  
DRAFTSMAN TO DOUBLE SCALE

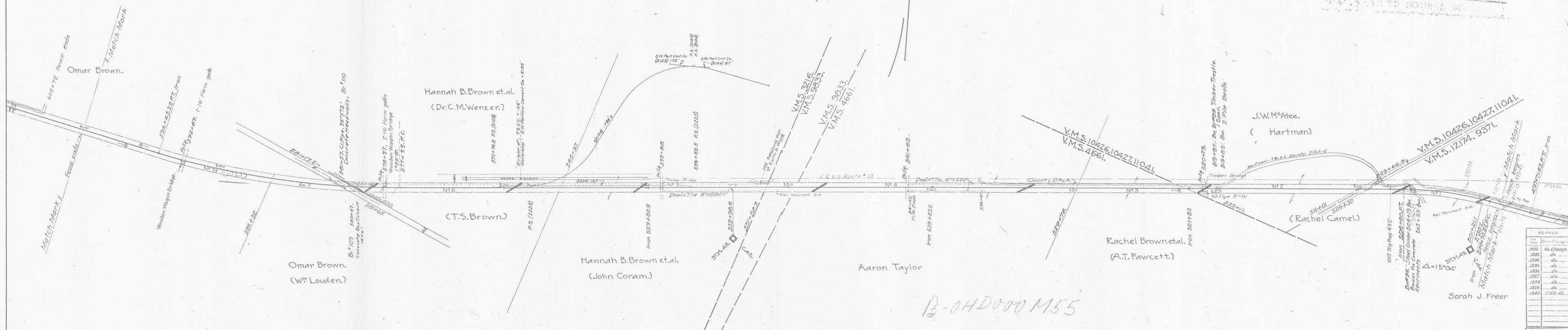

| REVISED | Date | Change    |
|---------|------|-----------|
| 1852    |      | No Change |
| 1853    |      | do        |
| 1854    |      | do        |
| 1855    |      | do        |
| 1856    |      | do        |
| 1857    |      | do        |
| 1858    |      | do        |
| 1859    |      | do        |
| 1860    |      | do        |
| 1861    |      | do        |
| 1862    |      | do        |
| 1863    |      | do        |
| 1864    |      | do        |

| REVISED | Date | Change    |
|---------|------|-----------|
| 1865    |      | No Change |
| 1866    |      | No Change |
| 1867    |      | No Change |
| 1868    |      | No Change |
| 1869    |      | No Change |
| 1870    |      | No Change |
| 1871    |      | No Change |
| 1872    |      | No Change |
| 1873    |      | No Change |
| 1874    |      | No Change |
| 1875    |      | No Change |
| 1876    |      | No Change |
| 1877    |      | No Change |
| 1878    |      | No Change |
| 1879    |      | No Change |
| 1880    |      | No Change |
| 1881    |      | No Change |
| 1882    |      | No Change |
| 1883    |      | No Change |
| 1884    |      | No Change |
| 1885    |      | No Change |
| 1886    |      | No Change |
| 1887    |      | No Change |
| 1888    |      | No Change |
| 1889    |      | No Change |
| 1890    |      | No Change |
| 1891    |      | No Change |
| 1892    |      | No Change |
| 1893    |      | No Change |
| 1894    |      | No Change |
| 1895    |      | No Change |
| 1896    |      | No Change |
| 1897    |      | No Change |
| 1898    |      | No Change |
| 1899    |      | No Change |
| 1900    |      | No Change |

| No. | Grantor                                 | Grantee        | Instrument | Date           | Record      | Cont. No.          | Remarks                                   |
|-----|---|----------------|------------|----------------|-------------|--------------------|---|
| 1   | Sarah J. Freer                          | T & O C Ry Co  | W. Deed    | April 18, 1901 | DB V96 P564 | June 18, 1901 1841 | This is a part of parcel #6 Map 5         |
| 2   | J. W. McAtee                            | T & O C Ry Co  | W. Deed    | Apr 20, 1901   | DB V96 P566 | June 17, 1901 1842 | 26  |
| 3   | Rachel Brown et al                      | T & O C Ry Co  | W. Deed    | April 18, 1901 | DB V96 P562 | June 18, 1901 1843 | 27  |
| 4   | Aaron Taylor                            | J. T. Adams    | W. Deed    | Feb 26, 1898   | DB V96 P401 | Apr 20, 1901 1834  | See Note No. 1                            |
| 5   | Hannah B. Brown et al                   | J. T. Adams    | W. Deed    | Jan 1898       | DB V96 P401 | Apr 16, 1901 1835  | See Note No. 1                            |
| 6   | Hannah B. Thos. S. and Mary Klise Brown | J. T. Adams    | W. Deed    | Jan 1898       | DB V96 P401 | Apr 17, 1901 1836  | See Note No. 1                            |
| 7   | Omar Brown                              | T & O C Ry Co  | W. Deed    | Apr 18, 1901   | DB V96 P562 | Sept 23, 1901 1834 | This parcel continued as parcel #1, Map 7 |
| 8   | T. A. C. Ry. Co. & N.Y.C.R.R. Co.       | E. H. Thompson | Q.C. Deed  | Mar. 18, 1940  |             | 252                |   |

No. 1 -  
Conveyed to D & L F Ry Co by J. T. Adams by J.C. Deed, Feb 18, 1899  
Recorded Vol. 96 P460 Apr 29, 1901. Cont No. 1817

LOGAN COUNTY  
JEFFERSON TOWNSHIP

Note: All Property on this Map retired from operation 12-15-37

# THE PROPERTY WAS SECURED WITH  
THE NEW YORK CENTRAL  
RAILROAD COMPANY  
JUNE 30, 1952  
AUTHORIZED BY I. C. C. Docket No. 17780  
RECEIVED JUNE 18, 1952

RIGHT OF WAY AND TRACK MAP  
# THE TOLEDO AND OHIO CENTRAL RAILWAY  
OPERATED BY

ST. MARYS BRANCH -- MAIN LINE  
FROM STATION 500+00 TO STATION 600+00  
SCALE 1 INCH = 200 FEET  
JUNE 30, 1918  
OFFICE OF VALUATION ENGINEER, COLUMBUS, OHIO.  
\* OPERATED BY THE NEW YORK CENTRAL RAILROAD COMPANY SUBSEQUENT TO DECEMBER 31, 1921.

V-303  
6

V.3.  
6

INDEXED ON MAP  
6216 10P-3

| SCHEDULE OF PROPERTY (Continued)                              |                                |            |               |
|---|--------------------------------|------------|---------------|
| Grantor   | Grantee                        | Instrument | Date          |
| T & O C Ry Co   | Francis Curt and Leo B Medulla | O.C. Deed  | Nov 5, 1930   |
| This parcel conveyed in same deed as Parcel No. 14, this map. |                                |            |               |
| T & O C Ry Co & NYC R.R. Co                                   | E. H. Thompson                 | O.C. Deed  | Mar. 15, 1940 |
| do  | Zanesfield and Sun Club, Inc.  | do         | Aug. 15, 1940 |
| do  | do                             | do         | do            |
| do  | do                             | do         | do            |
| do  | Nora G. Shoofs                 | do         | Apr. 11, 1940 |
| do  | do                             | do         | Mar. 15, 1940 |
| do  | Keller J. Bell                 | do         | Apr. 21, 1944 |

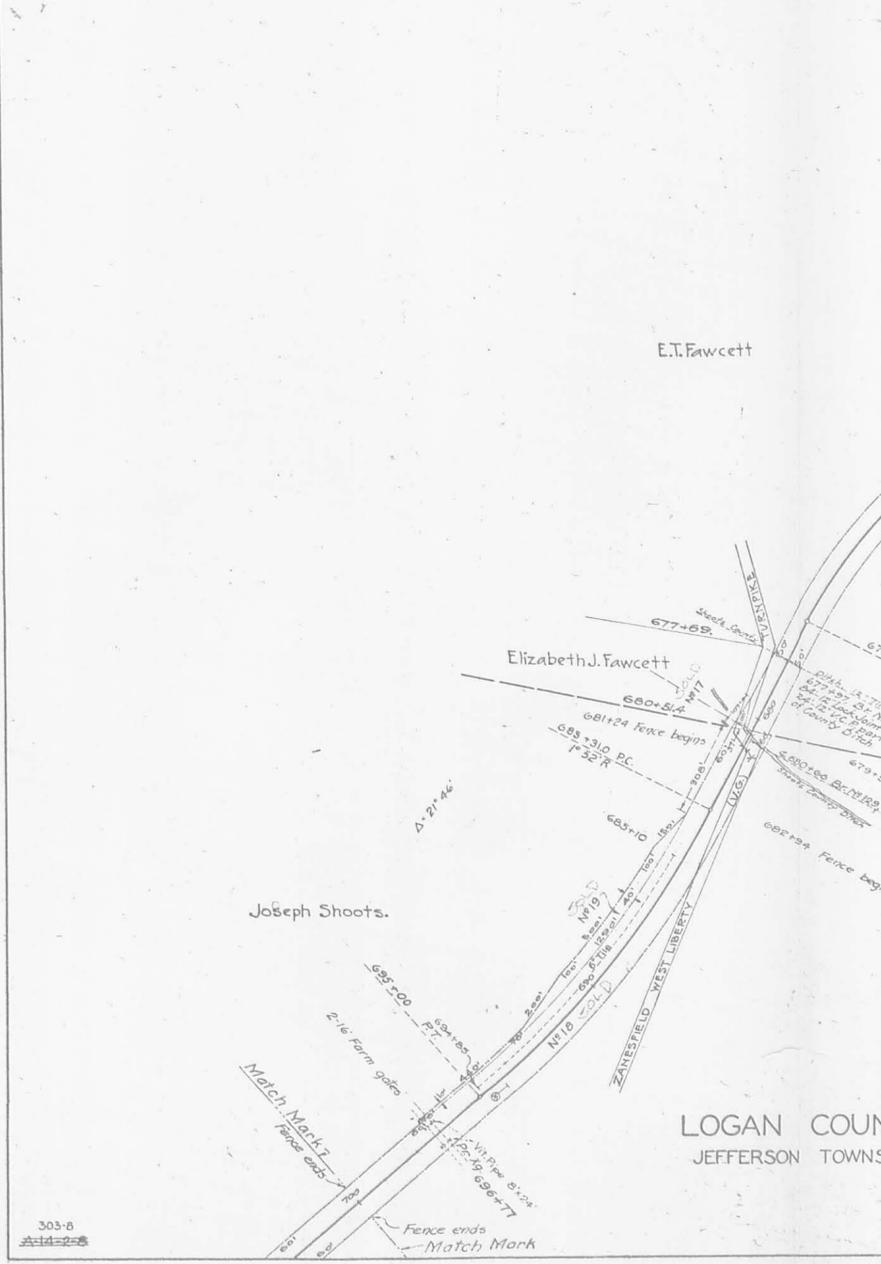

| No. | Grantor   | Grantee                                 | Instrument   | Date          | Record       | Cust. No.           | Remarks   |
|-----|---|---|--------------|---------------|--------------|---------------------|---|
| 1   | Omar Brown  | T & O C Ry Co                           | W. Deed      | Apr 18, 1901  | DB V96 P221  | Sept 23, 1901 13479 | This is a part of parcel #7, Map C.   |
| 2   | Wm. A. Loden  | J. T. Adams                             | W. Deed      | Jan 5, 1898   | DB V95 P455  | Apr 19, 1901 13463  | See Note No. 1  |
| 3   | Chas. M. Wanser, et al  | Columbus & North-western Ry Co          | Condemnation | Apr 21, 1898  | P46          |                     |   |
| 4   | Geo. D. Peters  | J. T. Adams                             | W. Deed      | Feb 20, 1899  | DB V95 P437  | Apr 23, 1901 13460  | See Note No. 2  |
| 5   | This parcel conveyed in same deed as parcel #4, this map.             |   |              |               |              |                     |   |
| 6   | Geo. D. Peters  | T & O C Ry Co                           | W. Deed      | June 12, 1906 | DB V104 P34  | Aug 16, 1906 13563  |   |
| 7   | Geo. D. Peters  | D & L N Ry Co                           | W. Deed      | Feb 20, 1899  | DB V95 P439  | Mar 23, 1901 13559  | This deed also conveys parcel #8, this map  |
| 8   | This parcel conveyed in same deed as parcel #7, this map.             |   |              |               |              |                     |   |
| 9   | E. C. Williams  | T & O C Ry Co                           | W. Deed      | Apr 18, 1901  | DB V95 P568  | June 17, 1901 13444 |   |
| 10  | No paper title found. Held by adverse possession and claimed by Ry Co |   |              |               |              |                     |   |
| 11  | Elizabeth Peters  | T & O C Ry Co                           | Lease        | June 16, 1904 | DB V2 P70    | June 27, 1904 13594 | Used but not owned See Note No. 3   |
| 12  | Oren Outland  | T & O C Ry Co                           | Lease        | June 16, 1904 | DB V2 P66    | June 16, 1904 13589 | Used but not owned See Note No. 3   |
| 13  | Rebecca J. Pennock  | T & O C Ry Co                           | Lease        | June 16, 1904 | DB V2 P69    | June 27, 1904 13590 | Used but not owned See Note No. 3   |
| 14  | Susan Horn  | Clifford Burton, Trustee, T & O C Ry Co | W. Deed      | June 16, 1904 | DB V100 P384 | June 25, 1904 13582 | Conveyed to T&O C Ry by Clifford Burton by Quit Claim Deed dated Oct 16, 1904. Deed to Francis Curt et al Nov 5, 1930. C.R. No. AB-10.  |
| 15  | T. F. Bushey  | Clifford Burton, Trustee, T & O C Ry Co | W. Deed      | July 22, 1904 | DB V100 P444 | July 27, 1904 13587 | Conveyed to T&O C Ry by Clifford Burton by Quit Claim Deed dated Oct 16, 1904. Deed to Francis Curt et al Nov 5, 1930. C.R. No. AB-10.  |
| 16  | E. T. Fawcett   | D & L N Ry Co                           | W. Deed      | Feb 15, 1899  | DB V95 P410  | Apr 18, 1901 13567  |   |
| 17  | Elizabeth J. Fawcett  | J. T. Adams                             | W. Deed      | July 25, 1898 | DB V95 P410  | Apr 18, 1901 13565  | See Note No. 1  |
| 18  | Joseph Shoots   | J. T. Adams                             | W. Deed      | Feb 10, 1898  | DB V95 P445  | Apr 24, 1901 13564  | See Note No. 1. This parcel continued as parcel #1, Map C.  |
| 19  | Joseph Shoots   | T & O C Ry Co                           | W. Deed      | Dec 21, 1908  | DB V107 P516 | May 28, 1909 13666  |   |
| 20  | Dorothy T. Burton   | T & O C Ry Co                           | G.C. Deed    | Dec 16, 1894  | DB V105 P111 | Dec 15, 1894 6999   | [Detail omitted to clear title to Parcel No. 14 and 15. This deed, obtained on voluntary sale as owned by George H. Burton, is held to Francis Curt et al, Nov 5, 1930, Completion Report No. AB-10.] |
| 21  | This parcel conveyed in same deed as Parcel No. 14, this map.         |   |              |               |              |                     |   |

LOGAN COUNTY  
JEFFERSON TOWNSHIP

AB-R.O.N-B-2.69 AC.  
31.30 AC. TOTAL

2.69

B-OH.D.0000 M55

|       |           |           |             |
|-------|-----------|-----------|-------------|
| OWNER | VACUATION | SUB SHEET | REAL ESTATE |
| 500   | 3030      | 7         | REGION      |

THIS TRACING IS 50% ORIGINAL SIZE.  
DRAFTSMAN TO DOUBLE SCALE

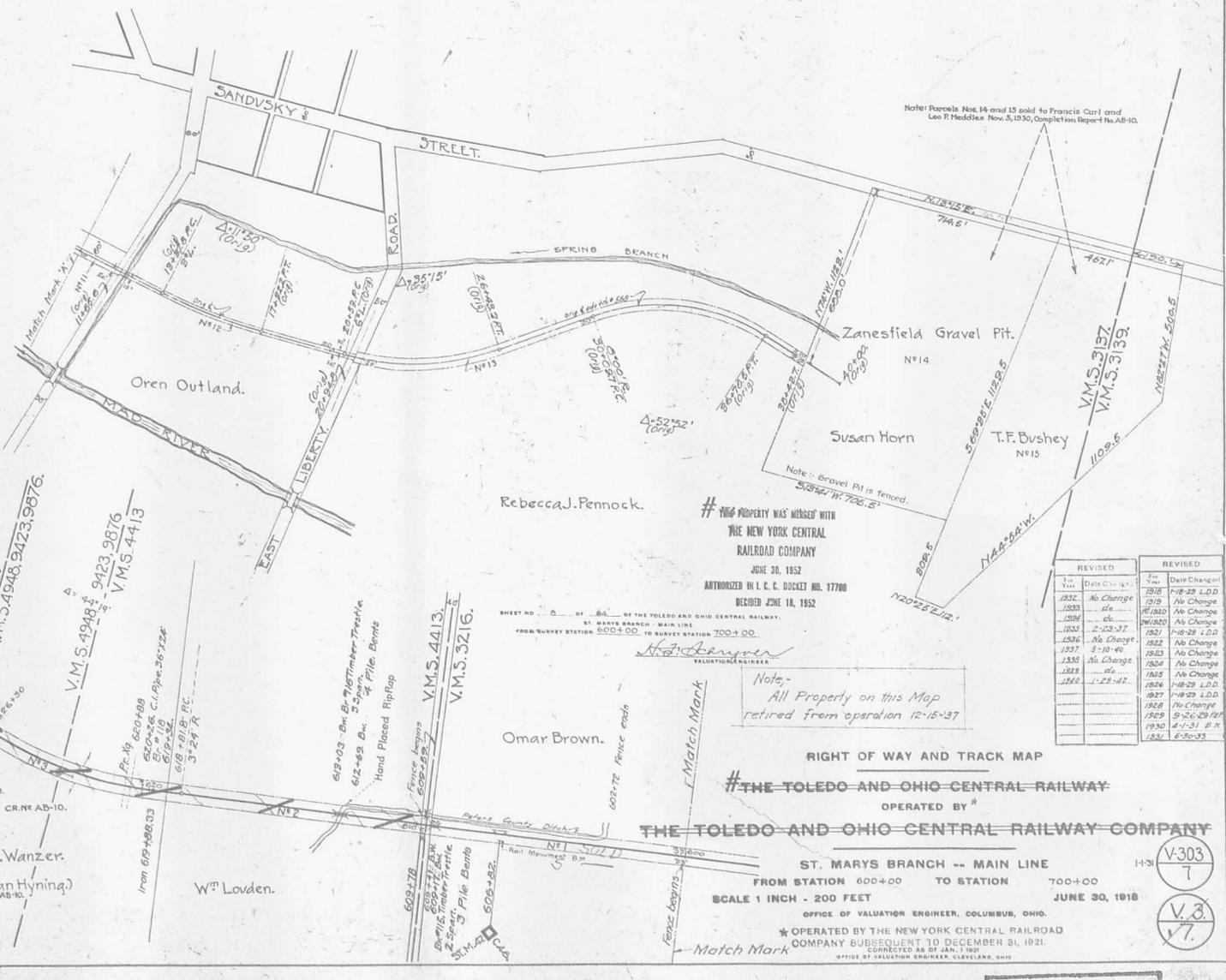

# THIS PROPERTY WAS MERGED WITH  
THE NEW YORK CENTRAL  
RAILROAD COMPANY  
JUNE 30, 1952  
AUTHORIZED IN L. C. DOCKET NO. 17700  
RECORDED JUNE 18, 1952

| REVISED | REVISED |
|---------|---------|
| Date    | Date    |
| 1932    | 1932    |
| 1933    | 1933    |
| 1934    | 1934    |
| 1935    | 1935    |
| 1936    | 1936    |
| 1937    | 1937    |
| 1938    | 1938    |
| 1939    | 1939    |
| 1940    | 1940    |
| 1941    | 1941    |
| 1942    | 1942    |
| 1943    | 1943    |
| 1944    | 1944    |
| 1945    | 1945    |
| 1946    | 1946    |
| 1947    | 1947    |
| 1948    | 1948    |
| 1949    | 1949    |
| 1950    | 1950    |
| 1951    | 1951    |
| 1952    | 1952    |

Note -  
All Property on this Map  
retired from operation 12-15-37

RIGHT OF WAY AND TRACK MAP  
# THE TOLEDO AND OHIO CENTRAL RAILWAY  
OPERATED BY  
THE TOLEDO AND OHIO CENTRAL RAILWAY COMPANY

ST. MARYS BRANCH -- MAIN LINE  
FROM STATION 600+00 TO STATION 700+00  
SCALE 1 INCH = 200 FEET  
JUNE 30, 1918

OFFICE OF VALUATION ENGINEER, COLUMBUS, OHIO.  
OPERATED BY THE NEW YORK CENTRAL RAILROAD COMPANY SUBSEQUENT TO DECEMBER 31, 1921.  
OFFICE OF VALUATION ENGINEER, CLEVELAND, OHIO.

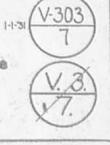

INDEXED ON MAP  
0216 1127

All that parcel of land located at West Liberty, situate in the County of Logan, and the State of Ohio, and being part of the Southwest 1/4 of Section 27, Township 5, Range 13 M.R.S., being designated as Parcel No. OH.G 000 D9-7 on Railroad Valuation Map No. 072-5420-0-27-7, as revised to March 7, 1967, and being all of the land of The Cleveland, Cincinnati, Chicago and St. Louis Railway Company, as Shown on the Map, which is described as follows:

All the land between Company Road No. 193 (Runkle Street), and the northerly line of the Mad River.

The above described parcel or parcels are identified in the records of the United States Railway Association as Line Code 8231-106.

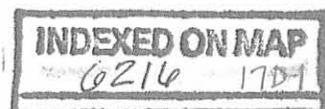



All that parcel of land located at West Liberty, situate in the County of Logan, in the State of Ohio, and being part of Southwest 1/4 of the Northeast 1/4 of Section 33, Township 5, Range 13, M.R.S., designated as Parcel No. OH.G 000 EO-8 on Railroad Valuation Map No. 072-5420-0-27-7, as revised to March 7, 1967, and being all of the land of The Cleveland, Cincinnati, Chicago and St. Louis Railway Company, as shown on the Map, which lies northeasterly of the following described line:

Beginning at a point on the northerly line of County Road No. 193 (Runkle Street), distant 75 feet, measured eastwardly and at right angles from the centerline of right-of-way of said Railway Company;

Thence, extending in a northwesterly direction, parallel to said centerline 1320 feet, more or less, to a point on a line of land of others, the point of ending.

The above described parcel or parcels are identified in the records of the United States Railway Association as Line Code 8231-106.

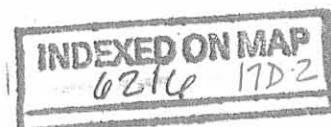







All that parcel of land located at DeGraff, and situate in the Township of Miami, County of Logan and State of Ohio, being part of the Northeast 1/4 of the Northeast 1/4 of Section 12 of Township 2, Range 14, M.R.S., and designated as Parcel No. OH-D000 08-7 on Railroad Valuation Map No. 073-5410-0-35-7, as revised to December 23, 1970, and being all of the land of The Cleveland, Cincinnati, Chicago and St. Louis Railway Company, Indianapolis Division, as shown on the Map, which lies north-easterly of Koke Street and northwesterly of the following described line:

Beginning at a point on the northeasterly line of Koke Street, distant 40 feet, measured northwestwardly and radially from the centerline of the main track of said Railway Company, as it was located on November 21, 1975;

Thence, extending from said point of beginning northeastwardly 220 feet, more or less, to a point on the line that separates the Northeast 1/4 of the Northeast 1/4 of Section 12 from the Northwest 1/4 of the Northwest 1/4 of Section 6, the point of ending.

The above described parcel or parcels are identified in the records of the United States Railway Association as Line Code 8305-150.0.

Subject to the easement and right to use, operate, maintain, repair, renew, replace and remove the existing track or tracks on and across the above described property.

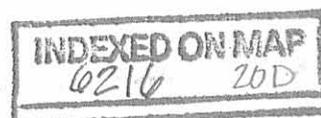



PARCEL A.

Document No. CCC&StL-CRC-RP-77

All that parcel of land located at Bellefontaine, situate in the County of Logan and the State of Ohio, being designated Parcel No. OH.D090 18-8 on Railway Valuation Maps Nos. 072-5410-0-ST29-7 as revised to December 31, 1968, and 072-5410-0-ST30A-7 as revised to December 31, 1961, and being all of the land, as shown on the Maps, of the Cleveland, Cincinnati, Chicago and St. Louis Railway Company which lies southerly, southeasterly, and northerly of the following described lines:

Beginning northerly line of a 16 foot cinder driveway, at a point thereon distant 170 feet, +, measured southeastwardly and radially from the centerline of said Railway Company's Track No. 294, at a point on said centerline of track distant 1,610 feet, +, measured southwestwardly along said centerline of track from another point thereon opposite the said Railway Company's Mile Post 138;

Thence, extending (1) westwardly along said northerly line of a cinder driveway 125 feet, +, to a point distant 60 feet measured southeastwardly and radially from said centerline of Track No. 294; thence (2) southeastwardly and parallel with said centerline of track 4,080 feet, +, to a point on the prolongation westwardly of a northerly line of land of other owners; thence (3) eastwardly along said prolongation westwardly 110 feet, +, to a point at a corner of land of other owners, the point of ending.

The above described parcel is identified in the records of the United States Railway Association as Line Code 8105-139/141.

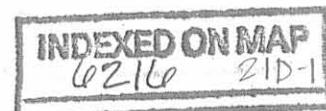

All that parcel of land located at Bellefontaine, situate in the County of Logan and the State of Ohio, being designated Parcel No. OH.D090 10-1 on Railroad Valuation Map No. 072-5410-0-ST30A-7, as revised to December 31, 1961, and being all the land of the Cleveland, Cincinnati, Chicago & St. Louis Railway Company as shown on the Map, which lies easterly of the following described line:

Beginning at a point in the line of land of other owners, 15 feet, ±, measured northwardly and at right angles from the southerly line of the eastbound Right-of-Way of U.S. Highway Route 33, Dual O. H. Bridge No. 122, said beginning point being 40 feet measured eastwardly and at right angles from the center-line of Track No. 294 of said Company as it was located on December 9, 1975;

Thence, extending southwardly and parallel to said center-line of said Track 1,735 feet, ±, to the line of land of other owners, being the point of ending.

The above described parcel is identified in the records of the United States Railway Association as Line Code 8105-139/141.

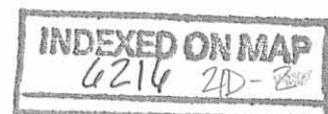



Parcel B

Document No. CCC&STL-CRC-RP-77

All that parcel of land located at Bellfontaine, situate in the County of Logan and the State of Ohio, being a part of Section 35, being designated Parcel No. OH.D090 11-3 on Railroad Valuation Map No. 072-5410-0-ST30A-7 as revised to December 31, 1961, and being all of the land of the Cleveland, Cincinnati, Chicago and St. Louis Railway Company which lies within the following three lines:

Beginning at a point at a corner of the land of other owners, which said point is at the intersection of Sections 5, 6, 35, and 36;

Thence, extending (1) eastwardly along a southerly line of the said land of other owners 700 feet, more or less, to a point at a corner on the northwesterly right-of-way line of the said Company; thence (2) southwestwardly in a straight line 1,255 feet, more or less, to a point on the westerly line of Section 35, which said point is on the easterly line of land of other owners distant 125 feet, more or less, measured southwardly along the said easterly line of land from another point thereon at the southerly line of Charles Avenue; thence (3) northwardly along the said easterly line of land of other owners, which said line is also the westerly line of Section 35, 1,090 feet, more or less, to the point of beginning.

The above described parcel is identified in the records of the United States Railway Association as Line Code 8105-139-141.

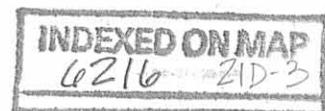

RICHARD E. GROVES ETUX  
(6-9-77)

Parcel C

0.214 A.

Document No. CCC&StL-CRC-RP-77

75-03655

All that parcel of land located at Bellefontaine, situate in the County of Logan, and the State of Ohio, being designated Parcel No. OH.D090 15-2 on Railroad Valuation Map No. 072-5410-0-ST30B-7 as revised to December 31, 1969 and being all the land of the Cleveland, Cincinnati, Chicago & St. Louis Railway Company as shown on the Map which lies easterly of the following described line:

Beginning at a point on the northerly line of Court Street, 20 feet measured easterly and radially from the centerline of the near track of said Company as it was located on December 9, 1975;

Thence, extending northwestwardly and parallel to said centerline of said track, 230 feet, ±, to the southerly line of Columbus Street, the place of ending.

The above described parcel is identified in the records of the United States Railway Association as Line Code 8105-139/141.

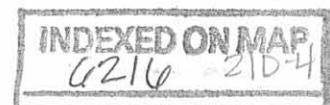

Parcel C

Document No. CCC&StL-CRC-RP-77

All that parcel of land located at Bellfontaine, situate in the County of Logan and the State of Ohio, being a part of Section 35, being designated Parcel No. OH.D090 12-5 on Railroad Valuation Maps Nos. 072-5410-0-ST30A-7 as revised to December 31, 1961 and 072-5410-0-ST30B-7 as revised to December 31, 1967, and being all of the land of the Cleveland, Cincinnati, Chicago and St. Louis Railway Company, as shown on the Maps, which lies southerly, westerly, northerly, and westerly of the following described lines:

Beginning at a point at the intersection of an easterly line of land of other owners with the extreme easterly point of the southerly line of Myrtle Avenue, which said beginning point is also on the boundary line dividing Section 35 from Section 5;

Thence, extending (1) eastwardly along the prolongation eastwardly of the said southerly line of Myrtle Avenue 270 feet, more or less, to a point distant 15 feet, measured southwestwardly and radially from the centerline of the said Company's Track No. 95, at or near a point of switch common to the said Company's Track No. 97 and the said Track No. 95; thence (2) in a southeasterly direction, parallel with the said Track No. 95, 325 feet, more or less, to a point opposite a point of switch common to the said Track No. 95 and the said Company's Track No. 96; thence (3) southeastwardly and parallel with the centerline of the said Track No. 96, 270 feet, more or less, to a point on the eastwardly prolongation of the southerly face of the said Company's Machine Shop No. 405; thence (4) westwardly along the said eastwardly prolongation and then along the said southerly face of Machine Shop No. 405, and then along the westwardly prolongation of the said southerly face a total of 310 feet, more or less, to a point on the said boundary line dividing Section 35 from Section 5; thence (5) southwardly along the said boundary line 635 feet, more or less, to a point on the northerly line of land of other owners, the point of ending.

The above described parcel of land is identified in the records of the United States Railway Association as Line Code 8105-139-141.

INDEXED ON MAP  
6216-21D-5

Parcel D ✓

Document No. CCC&StL-CRC-RP-77

All that parcel of land located at Bellefontaine, situate in the County of Logan, and the State of Ohio, being designated Parcel No. OH D090 16-4 on Railroad Valuation Map No. 072-5410-0-ST30B-7, as revised to January 18, 1971, and being all the land of The Cleveland, Cincinnati, Chicago and St. Louis Railway Company, as shown on the Map, which lies northwesterly of the following described line:

Beginning at a point on a line of land of others, 20 feet, measured northwestwardly and radially from the centerline of Track No. 201 of said Company, as it was located on November 21, 1975, at a point therein distant 135 feet, measured northeastwardly along said centerline of said track from another point therein opposite the said Company's Milepost 141;

Thence, extending northeastwardly and parallel to the centerline of said Track No. 201, 690 feet to the line of land of others, being the point of ending.

The above described parcel or parcels are identified in the records of the United States Railway Association as Line Code 8105-139-141.

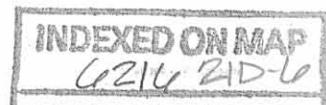



B. G. GRIFFIN  
154

#5

L.C. 8105  
M.P. 139-141

|       |                       |              |                    |
|-------|-----------------------|--------------|--------------------|
| OWNER | VALUATION SUB SECTION | SHEET NUMBER | REAL ESTATE REGION |
| 072   | 5410 - ST30A          | 7            | 7                  |

This Map is referred to in DOCUMENT NO. CCC 511-CRC-PP-77  
 certified by the United States Railway Association to the  
 Special Court pursuant to the Regional Rail Reorganization  
 Act of 1973, as amended.

Logan Co., Ohio

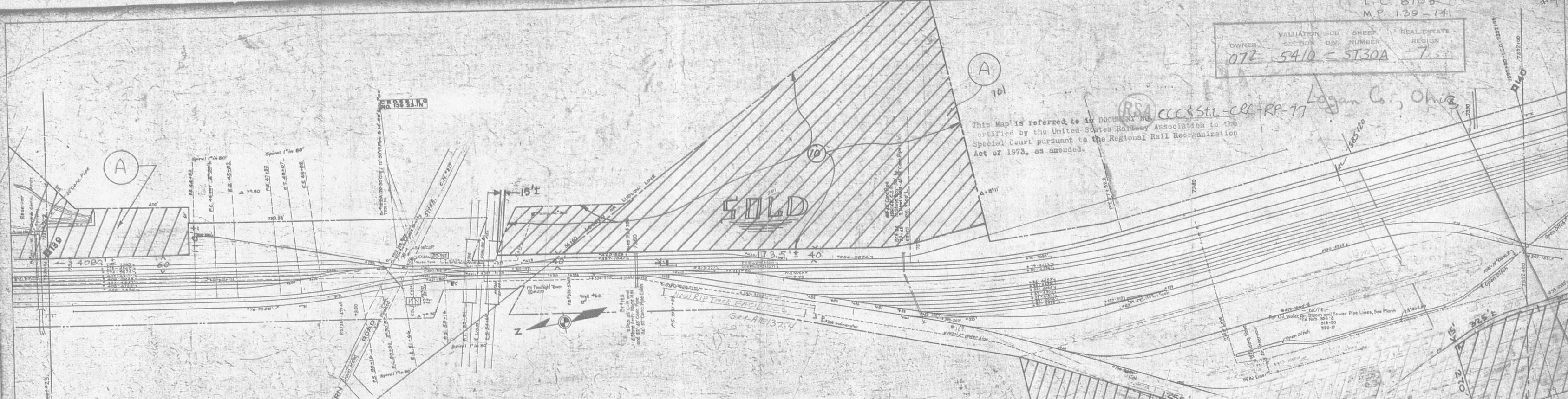

| Item | A.F.E. No. | Completion Report No. | Year | Item | A.F.E. No. | Completion Report No. | Year |
|------|------------|-----------------------|------|------|------------|-----------------------|------|
| 101  | 101        | 101                   | 1951 | 101  | 101        | 101                   | 1951 |
| 102  | 102        | 102                   | 1952 | 102  | 102        | 102                   | 1952 |
| 103  | 103        | 103                   | 1953 | 103  | 103        | 103                   | 1953 |
| 104  | 104        | 104                   | 1954 | 104  | 104        | 104                   | 1954 |
| 105  | 105        | 105                   | 1955 | 105  | 105        | 105                   | 1955 |
| 106  | 106        | 106                   | 1956 | 106  | 106        | 106                   | 1956 |
| 107  | 107        | 107                   | 1957 | 107  | 107        | 107                   | 1957 |
| 108  | 108        | 108                   | 1958 | 108  | 108        | 108                   | 1958 |
| 109  | 109        | 109                   | 1959 | 109  | 109        | 109                   | 1959 |
| 110  | 110        | 110                   | 1960 | 110  | 110        | 110                   | 1960 |
| 111  | 111        | 111                   | 1961 | 111  | 111        | 111                   | 1961 |
| 112  | 112        | 112                   | 1962 | 112  | 112        | 112                   | 1962 |
| 113  | 113        | 113                   | 1963 | 113  | 113        | 113                   | 1963 |
| 114  | 114        | 114                   | 1964 | 114  | 114        | 114                   | 1964 |
| 115  | 115        | 115                   | 1965 | 115  | 115        | 115                   | 1965 |
| 116  | 116        | 116                   | 1966 | 116  | 116        | 116                   | 1966 |
| 117  | 117        | 117                   | 1967 | 117  | 117        | 117                   | 1967 |
| 118  | 118        | 118                   | 1968 | 118  | 118        | 118                   | 1968 |
| 119  | 119        | 119                   | 1969 | 119  | 119        | 119                   | 1969 |
| 120  | 120        | 120                   | 1970 | 120  | 120        | 120                   | 1970 |

A OH DΦ 9 Φ 1 Φ 1  
 B " " 11-3  
 C " " 12-5

A 04.0000 90 9  
 91 2  
 92 4

MAP CORRECTIONS

1951 4-27-53  
 1952 4-3-55  
 1953 7-2-57  
 1954 5-2-57  
 1955 No Change  
 1956 11-10-58  
 1957 No Change  
 1958 11-20-58  
 1961 3-15-63

STATION MAP—TRACKS AND STRUCTURES  
 THE CLEVELAND, CINCINNATI, CHICAGO & ST. LOUIS RY.  
 Operated by  
 THE CLEVELAND, CINCINNATI, CHICAGO & ST. LOUIS RY. CO.  
 INDIANAPOLIS DIVISION—MAIN LINE  
 Sta. 7390 20 to Sta. 7392 00  
 Scale 1 in. = 100 Ft. June 30th, 1958  
 Office of Valuation Engineer, Cincinnati, O.

1" = 200'

CONNECTED TO DECEMBER 1959  
 CONNECTED TO DECEMBER 31, 1958  
 CONNECTED TO DECEMBER 1958  
 CONNECTED TO DECEMBER 1957

INDEXED ON MAP  
 0216 2152

117625-AME

#5

big 4-77

# BELFONTAINE LOGAN CO. OHIO

L. C. 8105  
M.P. 139-141

| OWNER | VALUATION | SUB DIV. | SHEET NUMBER | REAL ESTATE REGION |
|-------|-----------|----------|--------------|--------------------|
| 072   | 5410      | -        | ST30B        | 7                  |

This Map is referred to in DOCUMENT NO. CCC-STL-CRC-RP-77  
 certified by the United States Railway Association to the  
 Special Court pursuant to the Regional Rail Reorganization  
 Act of 1973, as amended.



| Item                       | A.P.    | Completion Report |
|----------------------------|---------|-------------------|
| 1. 10' x 10' concrete pad  | CE 3351 | 1910              |
| 2. 10' x 10' concrete pad  | CE 3352 | 1910              |
| 3. 10' x 10' concrete pad  | CE 3353 | 1910              |
| 4. 10' x 10' concrete pad  | CE 3354 | 1910              |
| 5. 10' x 10' concrete pad  | CE 3355 | 1910              |
| 6. 10' x 10' concrete pad  | CE 3356 | 1910              |
| 7. 10' x 10' concrete pad  | CE 3357 | 1910              |
| 8. 10' x 10' concrete pad  | CE 3358 | 1910              |
| 9. 10' x 10' concrete pad  | CE 3359 | 1910              |
| 10. 10' x 10' concrete pad | CE 3360 | 1910              |
| 11. 10' x 10' concrete pad | CE 3361 | 1910              |
| 12. 10' x 10' concrete pad | CE 3362 | 1910              |
| 13. 10' x 10' concrete pad | CE 3363 | 1910              |
| 14. 10' x 10' concrete pad | CE 3364 | 1910              |
| 15. 10' x 10' concrete pad | CE 3365 | 1910              |
| 16. 10' x 10' concrete pad | CE 3366 | 1910              |
| 17. 10' x 10' concrete pad | CE 3367 | 1910              |
| 18. 10' x 10' concrete pad | CE 3368 | 1910              |
| 19. 10' x 10' concrete pad | CE 3369 | 1910              |
| 20. 10' x 10' concrete pad | CE 3370 | 1910              |
| 21. 10' x 10' concrete pad | CE 3371 | 1910              |
| 22. 10' x 10' concrete pad | CE 3372 | 1910              |
| 23. 10' x 10' concrete pad | CE 3373 | 1910              |
| 24. 10' x 10' concrete pad | CE 3374 | 1910              |
| 25. 10' x 10' concrete pad | CE 3375 | 1910              |
| 26. 10' x 10' concrete pad | CE 3376 | 1910              |
| 27. 10' x 10' concrete pad | CE 3377 | 1910              |
| 28. 10' x 10' concrete pad | CE 3378 | 1910              |
| 29. 10' x 10' concrete pad | CE 3379 | 1910              |
| 30. 10' x 10' concrete pad | CE 3380 | 1910              |
| 31. 10' x 10' concrete pad | CE 3381 | 1910              |
| 32. 10' x 10' concrete pad | CE 3382 | 1910              |
| 33. 10' x 10' concrete pad | CE 3383 | 1910              |
| 34. 10' x 10' concrete pad | CE 3384 | 1910              |
| 35. 10' x 10' concrete pad | CE 3385 | 1910              |
| 36. 10' x 10' concrete pad | CE 3386 | 1910              |
| 37. 10' x 10' concrete pad | CE 3387 | 1910              |
| 38. 10' x 10' concrete pad | CE 3388 | 1910              |
| 39. 10' x 10' concrete pad | CE 3389 | 1910              |
| 40. 10' x 10' concrete pad | CE 3390 | 1910              |
| 41. 10' x 10' concrete pad | CE 3391 | 1910              |
| 42. 10' x 10' concrete pad | CE 3392 | 1910              |
| 43. 10' x 10' concrete pad | CE 3393 | 1910              |
| 44. 10' x 10' concrete pad | CE 3394 | 1910              |
| 45. 10' x 10' concrete pad | CE 3395 | 1910              |
| 46. 10' x 10' concrete pad | CE 3396 | 1910              |
| 47. 10' x 10' concrete pad | CE 3397 | 1910              |
| 48. 10' x 10' concrete pad | CE 3398 | 1910              |
| 49. 10' x 10' concrete pad | CE 3399 | 1910              |
| 50. 10' x 10' concrete pad | CE 3400 | 1910              |

OH D φ 9φ-137  
 149  
 152  
 164  
 176

THIS TRACING IS 50% ORIGINAL SIZE.  
 DRAFTSMAN TO DOUBLE SCALE

| DATE | REVISION  |
|------|-----------|
| 1951 | 4-27-53   |
| 1952 | 8-3-55    |
| 1953 | 7-8-57    |
| 1954 | 5-2-57    |
| 1955 | 4-1-58    |
| 1956 | 11-5-58   |
| 1957 | 7-1-60    |
| 1958 | 8-21-60   |
| 1959 | NA Change |
| 1962 | 1-17-71   |

STATION MAP—TRACKS AND STRUCTURES  
 THE CLEVELAND, CINCINNATI, CHICAGO & ST. LOUIS RY.  
 Operated by  
 THE CLEVELAND, CINCINNATI, CHICAGO & ST. LOUIS RY. CO.  
 INDIANAPOLIS DIVISION—MAIN LINE  
 Sta. 7088+00 to Sta. 7444+00  
 Scale 1/2" = 100 FT. Date 30th, 1916  
 Office of Vespasian Engineers, Cincinnati, O.

V-41  
 ST-30  
 b

INDEXED ON MAP  
 0210 ZIP-3

V.6. K10 A3A 078

11/76 CS-AME





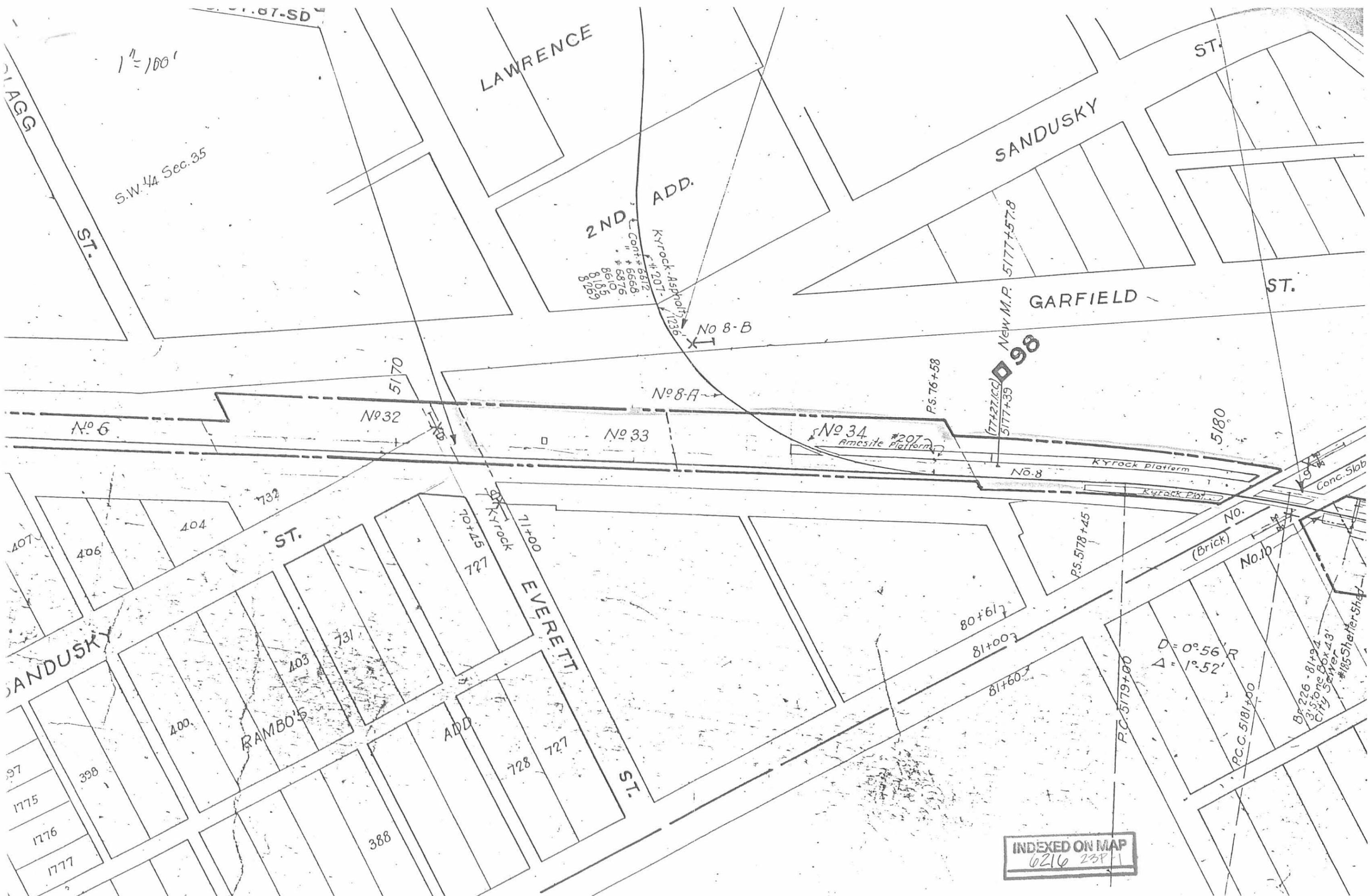

1" = 100'

S.W. 44 Sec. 35

LAWRENCE

SANDUSKY

ST.

2ND ADD.

KYrock Asphalt  
Cont. # 5612  
# 207  
# 6668  
# 6876  
# 8610  
# 8185  
# 8129

No 8-B

GARFIELD

ST.

5170

No 8-A

P.S. 76+58

New M.R. 98  
5177+39  
5177+57.8

No 6

No 32

No 33

No 34  
# 207  
Amesite Platform

No. 8

KYrock platform

5180

Conc. Slab

407

406

404

732

ST.

727

727

EVERETT

SANDUSKY

400

403

731

RAMBO'S

ADD.

728

727

ST.

397

398

1775

1776

1777

388

80+617

81+007

81+607

P.S. 5178+45

No. (Brick)

No. 10

D = 0° 56' R  
Δ = 1° 52' R

P.C. 5181+00

BR 226 - 81+94  
3.5 Stone Box 43  
City Sewer  
#185 Shafter Shed

P.C. 5179+00

INDEXED ON MAP  
6216 238

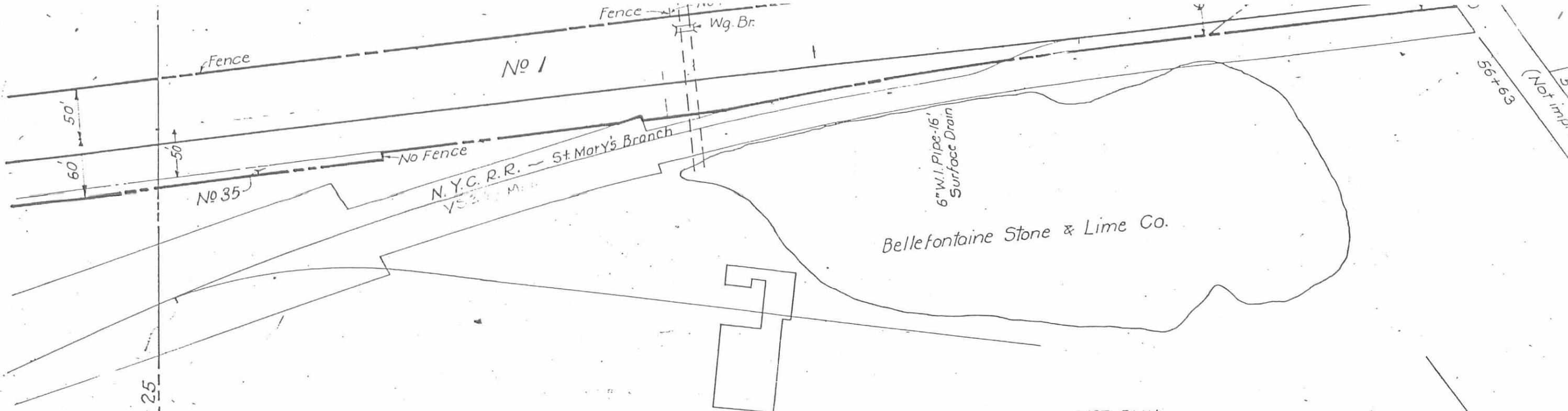

Match Mark for Next Sheet # 25

| NUMBER | GRANTOR  | GRANTEE        | INSTRUMENT      | DATE     | RECORD      | CUSTODIAN NUMBER | V-42C        | S-25-a |
|--------|--|----------------|-----------------|----------|-------------|------------------|--------------|--------|
| 1      | Thos. Irwin  | MR&LE RR       | Condemnation    | 8/28/45  | H/497       | 87               | Logan County | Ohio   |
| 2      |  |                | Possession      |          |             |                  | "            | "      |
| 3      | Right to cross Troy St.  |                | Ord. not found  |          |             |                  | "            | "      |
| 4      |  |                | Possession      |          |             |                  | "            | "      |
| 5      | Right to cross West St.  |                | Ord. not found  |          |             |                  | "            | "      |
| 6      |  |                | Possession      |          |             |                  | "            | "      |
| 7      | Right to cross Everett and Cutter Sts.   |                | Ord. not found  |          |             |                  | "            | "      |
| 8      |  |                | Possession      |          |             |                  | "            | "      |
| 9      | Right to cross Columbus St.  |                | Ord. not found  |          |             |                  | "            | "      |
| 10     | Geo. Foulk,  | CS&C. RR.      | QCD.            | 5/5/71   | 49/127      | 23               | "            | "      |
| 11     | The Columbus North-western Ry. Co.   | CCC&St. L. Ry. | Perpetual Lease | 4/13/98  | 2/85        | 90               | "            | "      |
| 12     | Abel J. Hellings   | CS&C. RR.      | QCD.            | 6/5/71   | 49/126      | 20               | "            | "      |
| 13     | Omitted  |                |                 |          |             |                  | "            | "      |
| 14     |  |                | Possession      |          |             |                  | "            | "      |
| 15     |  |                | "               |          |             |                  | "            | "      |
| 16     | Right to cross Alley   |                | Ord. not found  |          |             |                  | "            | "      |
| 17     | Thos. Martin,  | MR&LE. RR.     | WD              | 10/18/49 | T/430       | 19               | "            | "      |
| 18     |  |                | Ordinance       | 12/11/06 |             | 105-A            | "            | "      |
| 19     | Thos. Martin,  | MR&LE. RR.     | WD.             | 10/18/49 | T/430       | 19               | "            | "      |
| 19     | Lorenzo Lane,  | CCC&St. L. Ry. | QCD.            | 12/6/93  | 82/216      | 17               | "            | "      |
| 20     | Omitted  |                |                 |          |             |                  | "            | "      |
| 21     | Jared S. Dawson  | MR&LE. RR.     | WD.             | 10/19/50 | 11/723      | 16               | "            | "      |
| 22     | Right to cross Chillicothe St.   |                | Ord. not found  |          |             |                  | "            | "      |
| 23     | See below<br>The Columbus North-western Ry. Co.  | CCC&St. L. Ry. | Perpetual Lease | 4/13/98  | 2/85        | 90               | "            | "      |
| 24     | C. P. Buckingham   | MR&LE. RR.     | QCD.            | 11/15/47 | 44/379      | 18               | "            | "      |
| 25     | Right to occupy property of Big 4-Ind'pls. Div. in vicinity of Chillicothe and Elm St. |                |                 |          |             |                  | "            | "      |
| 26     | Right to cross Border St.  |                | Ord. not found  |          |             |                  | "            | "      |
| 27     | Benjamin Stanton   | MR&LE. RR.     | Release         | 7/3/45   | 84/197      | 14               | "            | "      |
| 28     | Right to cross Auburn St.  |                | Ord. not found  |          |             |                  | "            | "      |
| ** 29  | James B. Nevin   | CCC&St. L. Ry. | Court Decision  | 8/15/04  | C.P.N. /722 | 75               | "            | "      |
| *** 30 | C. P. Buckingham   | MR&LE. RR.     | QCD.            | 11/15/47 | 44/379      | 18               | "            | "      |
| 31     | Omitted  |                |                 |          |             |                  | "            | "      |
| 8-A    | Right to cross property between Gorfield St. and right of way                          |                | Ord. not found. |          |             |                  | "            | "      |
| 8-B    | Right to cross Gorfield St with switch   |                | Ord. not found  |          |             |                  | "            | "      |

INDEXED ON MAP  
6210 238-2

| NUMBER | GRANTOR          | GRANTEE             | INSTRUMENT | DATE    | RECORD  | CUSTODIAN |              |      |
|--------|------------------|---------------------|------------|---------|---------|-----------|--------------|------|
|        |                  |                     |            |         |         | NUMBER    | V-42-C       | S25a |
| 32     | Walter Slicer    | M.R. & L.E.R.R. Co. | Release    | 7/10/45 | 85/199  | 25        | Logan County | Ohio |
| 33     | D.L. Wrightsman  | M.R. & L.E.R.R. Co. | "          | 7/9/45  | 85/198  | 22        | "            | "    |
| 34     | Walter Slicer    | M.R. & L.E.R.R. Co. | "          | 7/10/45 | 85/199  | 25        | "            | "    |
| 35     | T.E. Houtz et al | C.S. & C.R.R.       | W.D.       | 8/6/27  | 132/367 | 183       | "            | "    |
| 36     | E.R. Gebby       | C.C.C. & St.L.Ry.   | Lease      | 4/30/28 |         | 13708     | "            | "    |
| 37     |                  |                     |            |         |         |           | "            | "    |
| 38     |                  |                     |            |         |         |           | "            | "    |
| 39     |                  |                     |            |         |         |           | "            | "    |
| 40     |                  |                     |            |         |         |           | "            | "    |
| 41     |                  |                     |            |         |         |           | "            | "    |
| 23     |                  |                     |            |         |         |           | "            | "    |

INDEXED ON MAP  
 4216 239-3

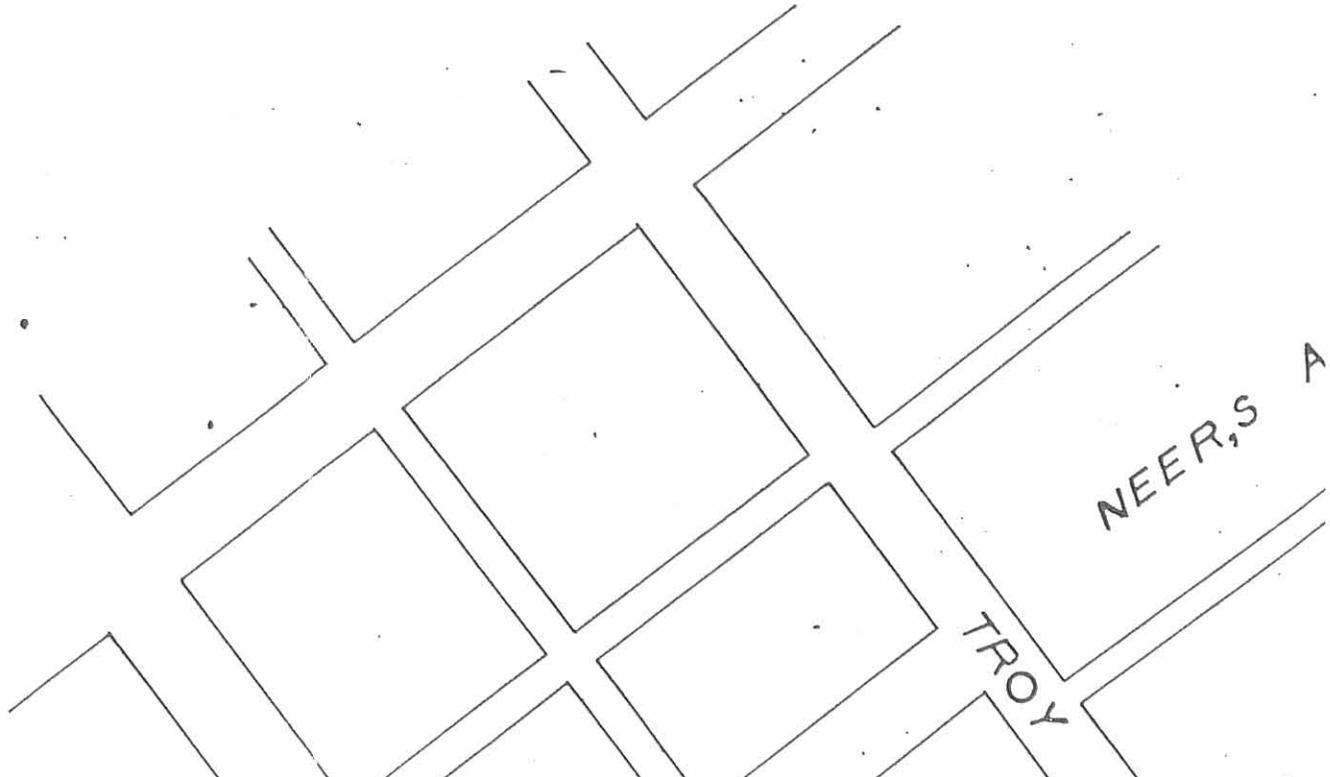

RECID 7-11-11 smj/ok

# Lee Surveying and Mapping Co., Inc.

Land Surveys • Topography • Subdivisions • Construction Layout

117 N. Madriver St.  
Bellefontaine OH 43311



Phone: (937) 593-7335  
Fax: (937) 593-7444  
surveys@lsminc.us

## DAYTON POWER AND LIGHT COMPANY 5.889 ACRES

Lying in Virginia Military Survey 9881, McArthur Township, Logan County, Ohio.

Being out of the Dayton Power and Light Company 116.50 acre tract as deeded and described in Official Record 329, Page 713, Parcel No. 5 of the Logan County Records of Deeds and being more particularly described as follows:

Commencing on a railroad spike found on the northeast corner of Virginia Military Survey 9881 and on the intersection of the center-lines of County Highway 37 and County Highway 130.

THENCE, with the north line of Virginia Military Survey 9881 and the center-line of County Highway 37 (60 feet wide), S 84°-26'-24"W, a distance of 1207.53 feet to a MAG nail set at the TRUE POINT OF BEGINNING.

THENCE, with the west line of the Wilson Anderson 19.2 acre tract (Vol. 387, Pg. 264, Parcel Two), with a curve to the left, having a central angle of 01°-58'-40", a radius of 5789.42 feet, an arc length of 199.83 feet, a chord bearing S 10°-14'-31"E, a distance of 199.82 feet to a 6 inch square concrete post found, passing a 5/8 inch iron rod set at 30.07 feet (chord distance).

THENCE, with the west lines of the said 19.2 acre tract, the William W. Lewis, Jr., 2.359 acre tract and 3.436 acre tract (O.R. 1006, Pg. 895 and O.R. 903, Pg. 699) and the Marvin Beck 2.902 acre tract (O.R. 364, Pg. 136), S 10°-32'-58"E, a distance of 2225.54 feet to a railroad spike found on the center-line of Township Road 56, passing a 5/8 inch iron rod set at 2194.60 feet and a 6 inch square concrete post found at 2206.66 feet.

THENCE, with the center-line of Township Road 56 (60 feet wide), S 65°-16'-41"W, a distance of 108.29 feet to a MAG nail set.

THENCE, with the east lines of the Jay Junior Richardson 15.20 acre tract (Vol. 347, Pg. 603), the Gregory A. Stites 29.054 acre tract (O.R. 481, Pg. 649, Tract I) and the Sandra J. Eleyet 0.149 acre tract (O.R. 851, Pg. 960), N 10°-32'-58"W, a distance of 2250.81 feet to a 5/8 inch iron rod set, passing a 5/8 inch iron rod set at 30.94 feet.

THENCE, with the east line of the said 0.149 acre tract, with a curve to the right, having a central angle of 02°-02'-37", a radius of 5894.42, an arc length of

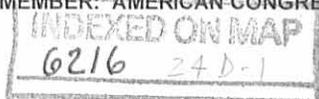

# Lee Surveying and Mapping Co., Inc.

Land Surveys • Topography • Subdivisions • Construction Layout

117 N. Madriver St.  
Bellefontaine OH 43311



Phone: (937) 593-7335  
Fax: (937) 593-7444  
surveys@lsminc.us

210.23 feet, a chord bearing N 10°-12'-33"W, a distance of 210.22 feet to a MAG nail set on the north line of Virginia Military Survey 9881 and the center-line of County Highway 37, passing a 5/8 inch iron rod set at 180.15 feet (chord distance).

THENCE, with the north line of Virginia Military Survey 9881 and the center-line of County Highway 37, N 84°-26'-24"E, a distance of 105.21 feet to the point of beginning.

Containing 5.889 acres, of which 0.147 acre is within the highway right-of-way.

Property is subject to any and all previous easements and rights-of-way of record.

The basis for bearings is the north line of Virginia Military Survey 9881, being S 84°-26'-24"W, and all other bearings are from angles and distances measured in a field survey by Lee Surveying and Mapping Co., Inc. on July 6, 2011.



Description prepared by:

A handwritten signature in black ink that reads 'William K. Bruce'.

William K. Bruce  
Professional Surveyor 7437  
July 7, 2011

33230511



REV'D 7-11-11 BY *WKB*

| CURVE | DELTA ANGLE | RADIUS   | ARC LENGTH | CHORD BEARING | CHORD LENGTH |
|-------|-------------|----------|------------|---------------|--------------|
| C1    | 02°02'37"   | 5894.42' | 210.23'    | N 10°12'33" W | 210.22'      |
| C2    | 01°58'40"   | 5789.42' | 199.83'    | S 10°14'31" E | 199.82'      |

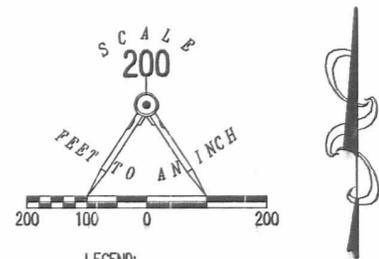
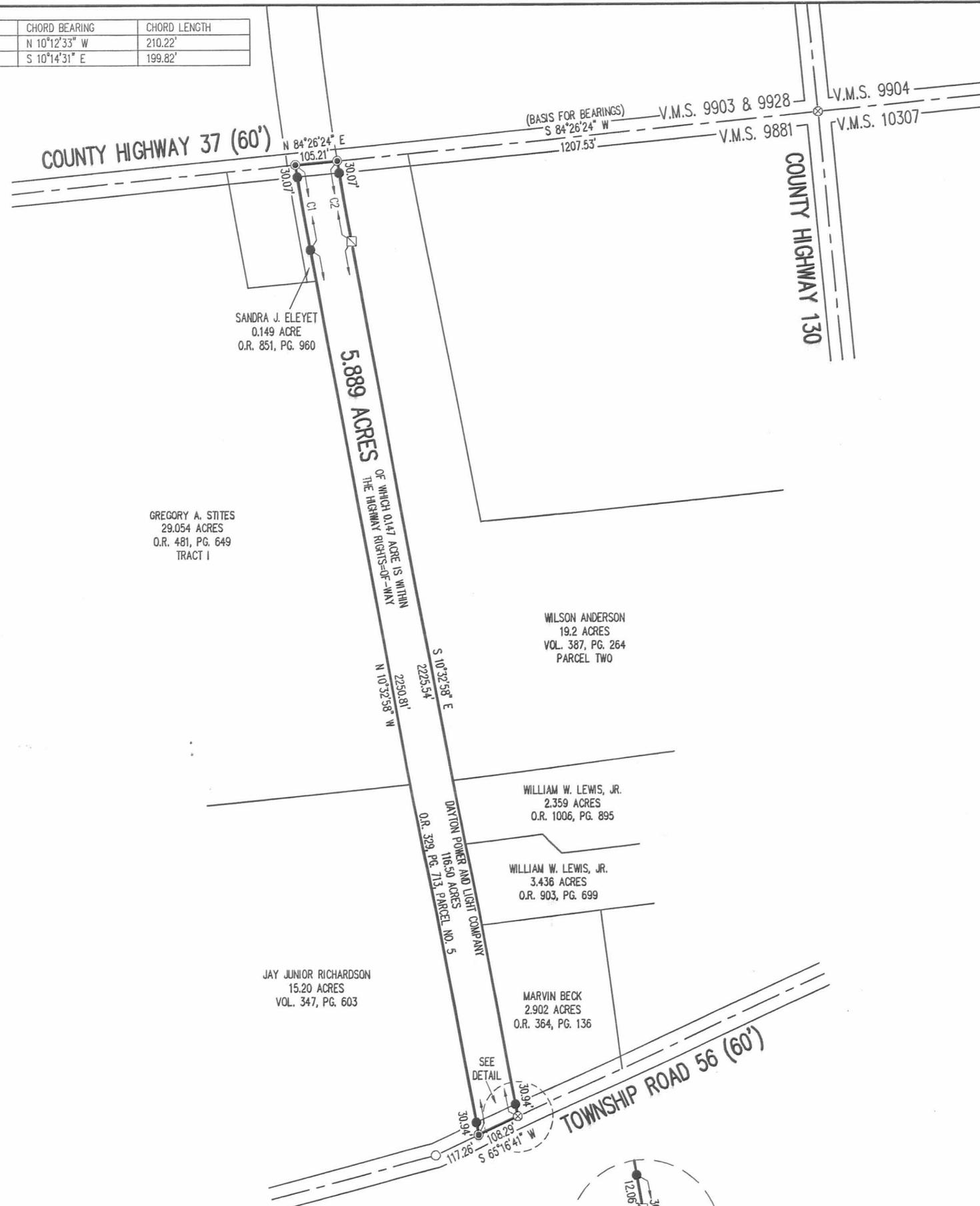

- LEGEND:
- ⊗ RAILROAD SPIKE FOUND
  - ⊙ MAG NAIL SET
  - 5/8 INCH IRON ROD FOUND
  - 5/8 INCH IRON ROD SET WITH PLASTIC I.D. CAP STAMPED "LSM 7437"
  - ⊠ 6 INCH SQUARE CONCRETE POST FOUND

SURVEY OF 5.889 ACRES OUT OF THE  
DAYTON POWER AND LIGHT COMPANY  
116.50 ACRE TRACT  
OFFICIAL RECORD 329, PAGE 713  
PARCEL NO. 5  
VIRGINIA MILITARY SURVEY 9881  
McARTHUR TOWNSHIP  
LOGAN COUNTY, OHIO

SURVEYED BY:  
*William K. Bruce*  
WILLIAM K. BRUCE  
PROFESSIONAL SURVEYOR 7437  
JULY 6, 2011



COPYRIGHT 2011 BY:  
LEE SURVEYING & MAPPING CO., INC.  
117 North Madriver Street  
BELLEFONTAINE, OHIO 43311  
(937) 593-7335  
surveys@lsmc.us  
KSS D0511 33230511 L-3323-2

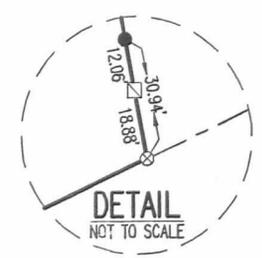

2 WORKING DAYS  
BEFORE YOU DIG  
CALL TOLL FREE 800-362-2764  
OHIO UTILITIES PROTECTION SERVICE

INDEXED ON MAP  
6216 2+P