

REC ID A-23-02 SWM OK

Lee Surveying and Mapping Co., Inc.

Land Surveys • Topography • Subdivisions • Construction Layout

117 N. Madriver St.
Bellefontaine OH 43311



Phone: (937) 593-7335
Fax: (937) 593-7444

PYLES 10.518 ACRES

Lying in Virginia Military Survey 9989, Richland Township, Logan County, Ohio.

Being out of the Wilbur Pyles and Mary Jane Pyles original 109 acre tract as deeded and described in Volume 343, Page 702 of the Logan County Records of Deeds and being more particularly described as follows:

Beginning at a 5/8 inch iron rod found in a monument box at the intersection of the north lines of Richland Township and Logan County and the center-line of County Highway 104 on center-line station 62+10 (Logan County Engineers Field Book 561, Pages 57 through 60).

THENCE, with the center-line of County Highway 104 (50 feet wide) the following four (4) courses:

S 26°-19'-13" E, a distance of 253.06 feet to a 3/4 inch iron rod found in a monument box on the north line of Virginia Military Survey 9989 on center-line station 59+56;

S 34°-21'-00" E, a distance of 523.49 feet to a 3/4 inch iron rod found on center-line station 54+34;

S 17°-24'-11" E, a distance of 330.25 feet to a MAG nail set on center-line station 51+04;

S 14°-42'-19" E, a distance of 437.45 feet to a MAG nail set at the TRUE POINT OF BEGINNING.

THENCE, with the center-line of County Highway 104, S 14°-42'-19" E, a distance of 417.35 feet to a 3/4 inch iron rod found on center-line station 42+49.

THENCE, with the north line of the Douglas C. Ritchey 40.91 acre tract (O.R. 309, Pg. 305, Tract II), S 83°-43'-12" W, a distance of 1137.11 feet to a 5/8 inch iron rod set, passing a 5/8 inch iron rod set at 25.27 feet.

THENCE, with the west line of Virginia Military Survey 9989 and the east line of the Jeffrey Johnson original 103.94 acre tract (O.R. 498, Pg. 600), N 7°-10'-34" W, a distance of 412.90 feet to a 5/8 inch iron rod set.

THENCE, N 83°-43'-12" E, a distance of 1082.42 feet to the point of beginning, passing a 5/8 inch iron rod set at 1057.15 feet.

Containing 10.518 acres, of which 0.268 acre is within the highway right-of-way.

The basis for bearings is the center-line of County Highway 104 just south of center-line station 59+56, being S 34°-21'-00" E, and all other bearings are from angles and distances measured in a field survey by Lee Surveying and Mapping Co., Inc. on April 19, 2002.

Description prepared by:

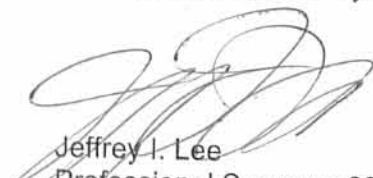

ORIGINAL STAMP IN GREEN

Jeffrey I. Lee
Professional Surveyor 6359
April 22, 2002

L-3353

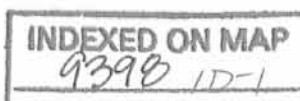

Lee Surveying and Mapping Co., Inc.

Land Surveys • Topography • Subdivisions • Construction Layout

117 N. Madriver St.
Bellefontaine OH 43311



Phone: (937) 593-7335
Fax: (937) 593-7444

PYLES 10.234 ACRES

Lying in Virginia Military Survey 9989, Richland Township, Logan County, Ohio.

Being out of the Wilbur Pyles and Mary Jane Pyles original 109 acre tract as deeded and described in Volume 343, Page 702 of the Logan County Records of Deeds and being more particularly described as follows:

Beginning at a 5/8 inch iron rod found in a monument box at the intersection of the north lines of Richland Township and Logan County and the center-line of County Highway 104 on center-line station 62+10 (Logan County Engineers Field Book 561, Pages 57 through 60).

THENCE, with the center-line of County Highway 104 (50 feet wide) the following three (3) courses:

S 26°-19'-13" E, a distance of 253.06 feet to a 3/4 inch iron rod found in a monument box on the north line of Virginia Military Survey 9989 on center-line station 59+56;

S 34°-21'-00" E, a distance of 523.49 feet to a 3/4 inch iron rod found on center-line station 54+34;

S 17°-24'-11" E, a distance of 330.25 feet to a MAG nail set on center-line station 51+04 at the TRUE POINT OF BEGINNING.

THENCE, with the center-line of County Highway 104, S 14°-42'-19" E, a distance of 437.45 feet to a MAG nail set.

THENCE, S 83°-43'-12" W, a distance of 1082.42 feet to a 5/8 inch iron rod set, passing a 5/8 inch iron rod set at 25.27 feet.

THENCE, with the west line of Virginia Military Survey 9989 and the east line of the Jeffrey Johnson original 103.94 acre tract (O.R. 498, Pg. 600), N 7°-10'-34" W, a distance of 412.90 feet to a 12 inch wood post found.

THENCE, with the south line of the said 103.94 acre tract, N 82°-36'-33" E, a distance of 1024.98 feet to the point of beginning, passing a 8 inch wood post found at 996.36 feet.

Containing 10.234 acres, of which 0.268 acre is within the highway right-of-way.

The basis for bearings is the center-line of County Highway 104 just south of center-line station 59+56, being S 34°-21'-00" E, and all other bearings are from angles and distances measured in a field survey by Lee Surveying and Mapping Co., Inc. on April 19, 2002.

Description prepared by:



ORIGINAL STAMP IN GREEN

Jeffrey I. Lee
Jeffrey I. Lee
Professional Surveyor 6359
April 22, 2002

L-3353

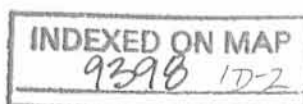

REV'D 4-23-02 SMJ/OK

HARDIN COUNTY
MCDONALD TOWNSHIP
RICHLAND TOWNSHIP
LOGAN COUNTY

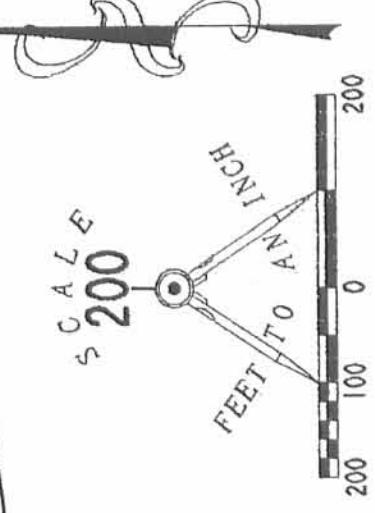

- LEGEND**
- 5/8 INCH IRON ROD SET
 - ◻ 5/8 INCH IRON ROD FOUND IN MONUMENT BOX
 - 3/4 INCH IRON ROD FOUND
 - ◻ 3/4 INCH IRON ROD FOUND IN MONUMENT BOX
 - MAG NAIL SET
 - ⊗ 8 INCH WOOD POST FOUND
 - ⊕ 12 INCH WOOD POST FOUND

STA. 62+10
S 26° 19' 13" E
253.06'

STA. 59+56
S 34° 21' 00" E
523.49'

(BASIS FOR BEARINGS)

VIRGINIA MILITARY SURVEY 12181
VIRGINIA MILITARY SURVEY 9989

REFERENCES
LOGAN COUNTY ENGINEER'S FILE
FIELD BOOK 561, PAGES 57 THRU 60

JEFFREY JOHNSON
ORIG. 103.94 ACRE
O.R. 498, PG. 600

COUNTY HIGHWAY 104 (50')

STA. 54+34
S 17° 24' 11" E
330.25'

STA. 51+04
S 14° 42' 19" E
437.45'

STA. 42+49
S 14° 42' 19" E
417.35'

STA. 29+32
M. 85.70.90 N
1316.58'

10.234 ACRES
OF WHICH 0.268 ACRE IS WITHIN THE
HIGHWAY RIGHT-OF-WAY

10.518 ACRES
OF WHICH 0.268 ACRE IS WITHIN THE
HIGHWAY RIGHT-OF-WAY

DOUGLAS C. RITCHEY
40.91 ACRES
O.R. 309, PG. 305
TRACT 11

VIRGINIA MILITARY SURVEY 9988
VIRGINIA MILITARY SURVEY 9989

JEFFREY JOHNSON
ORIG. 103.94 ACRE
O.R. 498, PG. 600

N 82° 36' 33" E
1024.98'

N 83° 43' 12" E
1082.42'

N 07° 10' 34" W
412.90'

N 07° 10' 34" W
412.90'

N 07° 10' 34" W
412.90'

1137.11'
S 83° 43' 12" W

**SURVEY OF TWO TRACTS OUT OF THE
WILBUR PYLES AND MARY JANE PYLES
ORIGINAL 109 ACRE TRACT
VOLUME 343, PAGE 702
VIRGINIA MILITARY SURVEY 9989
RICHLAND TOWNSHIP
LOGAN COUNTY, OHIO**



SURVEYED BY:
(Signature)
JEFFREY I. LEE
PROFESSIONAL SURVEYOR 6359
APRIL 19, 2002

COPYRIGHT 2002 BY:
LEE SURVEYING & MAPPING CO., INC.
117 North Madison Street
BELLEFONTAINE, OHIO 43311
(937) 593-7335

2 WORKING DAYS
BEFORE YOU DIG 800-362-2764
OHIO UTILITIES PROTECTION SERVICE.

ORIGINAL STAMP IN GREEN
INDEXED ON MAP
9398

D 401 L3353 L-3353-3

Recd 7-8-04 SMM AK

Acheson - 10.010 Acres

The following description is for a parcel of land located in the state of Ohio, County of Logan, Township of Richland, Virginia Military Survey 9989, and is 10.010 acres from an original 109.00 acre tract recorded in the name of John Steven and Joyce R. Acheson in Official Record 716, page 549. Said parcel being more particularly described as follows;

Beginning at a found $\frac{3}{4}$ " iron rod in a monument box at the intersection of the centerline of County Road 104(50 feet right-of-way) and the north line of V.M.S. 9989 and the northeast corner of a original 103.94 acre tract recorded in the name of David J. Willeke in Official Record 660, page 827 and a northwesterly corner of the abovementioned 109.00 acre tract. Said iron rod being further referenced by a found $\frac{3}{4}$ " iron rod in a monument box, at the centerline intersection of said road and the line between Hardin County and Logan County, bearing N 26° 28' 13" W 253.06 feet;

Thence, with said centerline, S 34°30'00" E (reference bearing in accordance with O.R. 660, p. 827) 523.49 to a found $\frac{3}{4}$ " iron rod found;

Thence, continuing with said centerline, S 17° 33' 11" E 130.68 feet to a set P.K. nail, said nail being the True Point of beginning of the following 10.010 acre tract;

Thence N 81° 52' 55" E, passing a set iron pipe at 25.31 feet, a total distance of 1026.50 feet to a set iron pipe;

Thence S 16° 06' 25" E 430.02 feet to a set iron pipe;

Thence S 81° 52' 55" W, passing a set iron pipe at 1001.33 feet, a total distance of 1026.50 feet to a set P.K. nail in the centerline of County Road 104;

Thence, with said centerline, N 14° 51' 19" W 230.57 feet to a found Mag nail, said nail being a southeast corner of the abovementioned Willeke;

Thence, continuing with said centerline, N 17° 33' 11" W 199.57 feet to the True point of beginning.

The above described parcel contains 10.010 acres with 0.247 acres within the right-of-way of County Road 104. Iron pipes set are $\frac{3}{4}$ " x 30" with caps stamped P.S. 7377. The above description was prepared from a field survey by William W. Browning P.S. 7377 during July of 2004.

William W. Browning
William W. Browning P.S. 7377
4444 State Route 187
London, Ohio 43140

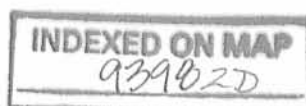

REC'D 7-0-04 SMM/AL

GRANTOR: John Steven & Joyce R. Acheson

10.010 Acre tract from an original 109.00 Acre tract
Official Record 716, page 549
Richland Township, Logan County, Ohio, V.M.S. 9989

HARDIN COUNTY
LOGAN COUNTY



SCALE IN FEET
1" = 100'

John S. & Joyce R. Acheson
O.R. 716, p. 549
109.00 Ac. (99.80 Ac. in Logan County)
36-008-00-00-009

V.M.S. 12181
V.M.S. 9989

David J. Willeke
O.R. 660, p. 827
103.94 ac
36-008-00-00-010
36-008-00-00-011

P.O.B.

(Ref. brng. O.R. 660, p. 827)
S34°30'00"E
523.49'

County Road 104
50' R/W

S17°33'11"E
130.68'

True P.O.B. (25.31')

N81°52'55"E

1026.50'

- - 3/4" Iron pipe set
- - 3/4" Iron rod found
- ▲ - Mag. nail found
- △ - P.K. nail set
- - 3/4" Iron rod found in monument box



I hereby certify that the hereon platted property was prepared from an actual survey.

William W. Browning
William W. Browning P.S. 7377 July-2004
4444 State Route 187
London, Ohio 43140
740.852.5325

INDEXED ON MAP
9398 2P

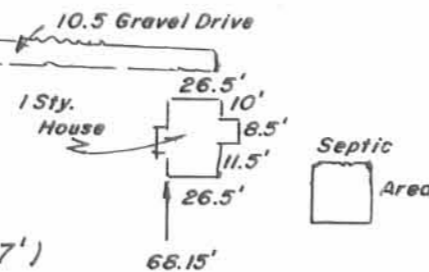
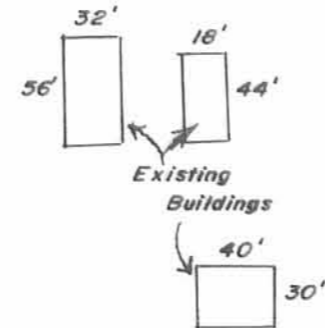

10.010 ACRES
(0.247 ac. in R/W)

S16°06'25"E

430.02'

S81°52'55"W

1026.50'

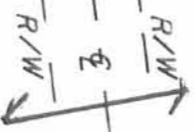

6-1-18



APPROVED

Land Surveys • Topography • Subdivisions • Construction Layout

Lee Surveying and Mapping Co.

117 N. Madriver St.
Bellefontaine OH 43311

Phone: (937) 593-7335
Fax: (937) 593-7444
surveys@lsminc.us



REED 1.000 ACRE

Lying in Virginia Military Survey 12181, Richland Township, Logan County, Ohio (all records referenced herein refer to the Logan County Records of Deeds).

Being out of the John E. Reed and Sheryl D. Reed 13 acre tract as deeded and described in Official Record 1096, Page 29 and being more particularly described as follows:

BEGINNING at a stone found in a monument box on the center-line of County Highway 104 (50 feet wide) in the south line of Virginia Military Survey 12181 and the north line of Virginia Military Survey 9989, said stone found being a common westerly corner to said 13 acre tract and the John Steven Acheson and Joyce R. Acheson 109 acre tract as deeded and described in Official Record 716, Page 549;

THENCE, with said center-line of County Highway 104, N 25°-41'-51" W, a distance of 150.00 feet to a MAG nail set, said MAG nail set bears S 25°-41'-51" E, a distance of 348.49 feet from a railroad spike found on said center-line;

THENCE, with new division lines through said 13 acre tract, the following two (2) courses:

- 1) N 83°-31'-19" E, passing a 5/8 inch iron rod set at a distance of 26.48 feet, a total distance of 307.54 feet to a 5/8 inch iron rod set; and
- 2) S 25°-41'-51" E, a distance of 150.00 feet to a 5/8 inch iron rod set on the south line of said Virginia Military Survey 12181 and north lines of said Virginia Military Survey 9989 and 109 acre tract;

THENCE, with the common line to said 13 acre and 109 acre tracts and said Virginia Military Surveys 12181 and 9989, S 83°-31'-19" W, passing a 5/8 inch iron rod set at a distance of 281.06 feet, a total distance of 307.54 feet to the **POINT OF BEGINNING**.

Containing 1.000 acre, more or less, of which 0.086 acre is within the highway right-of-way.

Iron rods set, where indicated, are 30 inches in length, 5/8 inch in diameter with an orange plastic I.D. cap stamped "P.S. 8533".

Property is subject to any and all previous easements and rights-of-way of record.

The basis for bearings, described herein, is Grid North, Ohio State Plane Coordinate System, North Zone, NAD83 (2011). Distances are expressed in U.S. Survey Feet. All other measurements are from angles and distances measured in a field survey by Lee Surveying and Mapping Co. on May 17, 2018.

Description prepared by:



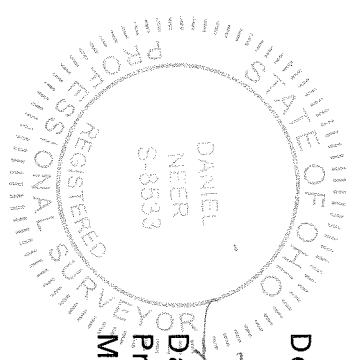

Daniel A. Neer
Professional Surveyor No. 8533
May 29, 2018



42730418

ACCESS MANAGEMENT NOTE:
 COUNTY HIGHWAY 104 IS CLASSIFIED AS A MINOR COLLECTOR ROAD.
 MINIMUM DRIVE SPACING IS 360'
 MINIMUM STOPPING SIGHT DISTANCE IS >495 (55 MPH)

DEED & SURVEY REFERENCES:
 O.R. 716, PG. 549
 O.R. 1096, PG. 29
 SURVEY BY JEFFREY I. LEE, P.S. 6359, FOR
 JOHN E. REED AND SHERYL D. REED, DATED
 JULY 27, 2006, REVISED SEPTEMBER 25, 2006.

LEGEND:
 STONE FOUND IN MONUMENT BOX
 RAILROAD SPIKE FOUND
 MAG NAIL SET
 5/8 INCH IRON ROD SET WITH PLASTIC I.D. CAP STAMPED "P.S. 8533"
 P.O.B. = POINT OF BEGINNING
 R/W = RIGHT-OF-WAY
 C/L = CENTER-LINE
 V.M.S. = VIRGINIA MILITARY SURVEY

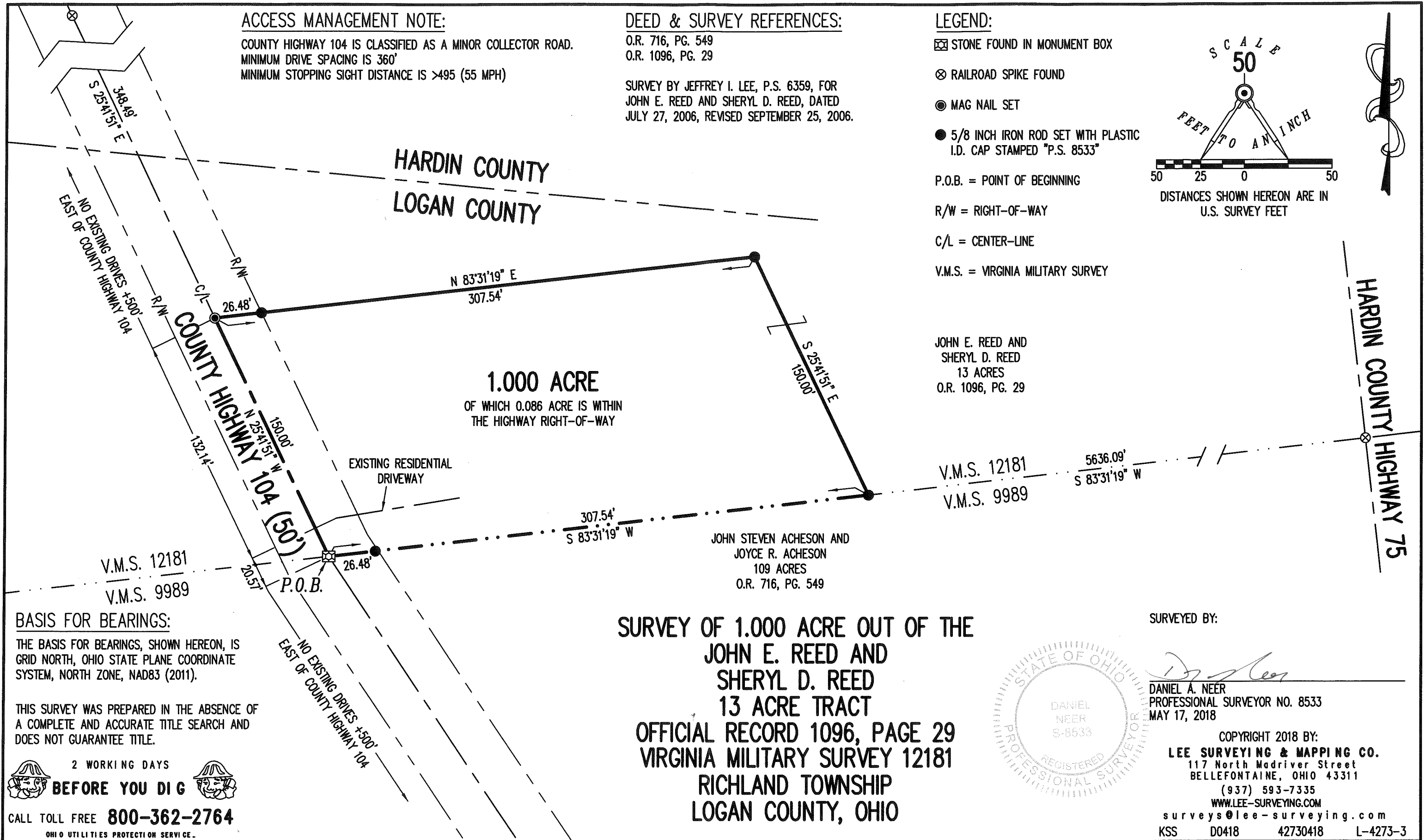
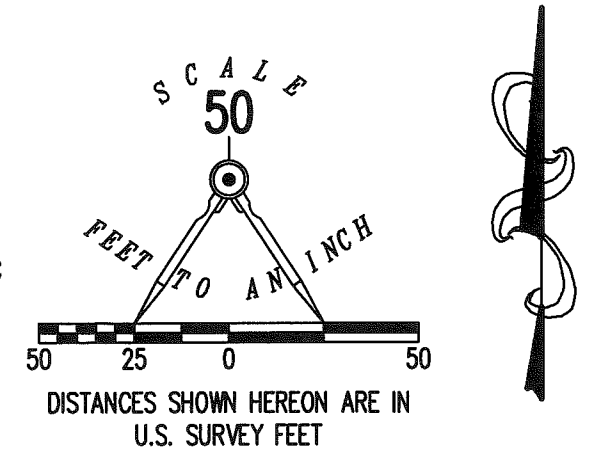

JOHN E. REED AND
 SHERYL D. REED
 13 ACRES
 O.R. 1096, PG. 29

JOHN STEVEN ACHESON AND
 JOYCE R. ACHESON
 109 ACRES
 O.R. 716, PG. 549

BASIS FOR BEARINGS:
 THE BASIS FOR BEARINGS, SHOWN HEREON, IS
 GRID NORTH, OHIO STATE PLANE COORDINATE
 SYSTEM, NORTH ZONE, NAD83 (2011).

THIS SURVEY WAS PREPARED IN THE ABSENCE OF
 A COMPLETE AND ACCURATE TITLE SEARCH AND
 DOES NOT GUARANTEE TITLE.

2 WORKING DAYS
BEFORE YOU DIG
 CALL TOLL FREE **800-362-2764**
 OHIO UTILITIES PROTECTION SERVICE.

**SURVEY OF 1.000 ACRE OUT OF THE
 JOHN E. REED AND
 SHERYL D. REED
 13 ACRE TRACT
 OFFICIAL RECORD 1096, PAGE 29
 VIRGINIA MILITARY SURVEY 12181
 RICHLAND TOWNSHIP
 LOGAN COUNTY, OHIO**

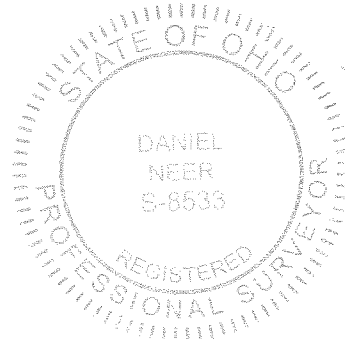

SURVEYED BY:

 DANIEL A. NEER
 PROFESSIONAL SURVEYOR NO. 8533
 MAY 17, 2018

COPYRIGHT 2018 BY:
LEE SURVEYING & MAPPING CO.
 117 North Madriver Street
 BELLEFONTAINE, OHIO 43311
 (937) 593-7335
 WWW.LEE-SURVEYING.COM
 surveys@lee-surveying.com
 KSS D0418 42730418 L-4273-3

INDEXED ON MAP
 9398