

REC'D 8-17-07 S.M.Y. & L.

Lee Surveying and Mapping Co., Inc.

Land Surveys • Topography • Subdivisions • Construction Layout

117 N. Madriver St.
Bellefontaine OH 43311



Phone: (937) 593-7335
Fax: (937) 593-7444

CULP 5.001 ACRES

Lying in Section 15, Town 3, Range 14, Harrison Township, Logan County, Ohio.

Being out of the Pauline Culp 80 acre tract as deeded and described in Official Record 313, Page 019, Tract II of the Logan County Records of Deeds and being more particularly described as follows:

Commencing on a stone found in a monument box on the west line of Section 15 at the intersection of the center-lines of Township Road 201 and County Highway 11.

THENCE, with the north line of the southwest quarter of Section 15 and the center-line of County Highway 11 (60 feet wide), S 87°-00'-35"E, a distance of 1842.98 feet to a MAG nail set at the TRUE POINT OF BEGINNING.

THENCE, with the north line of the southwest quarter of Section 15 and the center-line of County Highway 11, S 87°-00'-35"E, a distance of 298.00 feet to a MAG nail set.

THENCE, S 2°-59'-25"W, a distance of 731.00 feet to a 5/8 inch iron rod set, passing a 5/8 inch iron rod set at 30.00 feet.

THENCE, N 87°-00'-35"W, a distance of 298.00 feet to a 5/8 inch iron rod set.

THENCE, N 2°-59'-25"E, a distance of 731.00 feet to the point of beginning, passing a 5/8 inch iron rod set at 701.00 feet.

Containing 5.001 acres, of which 0.205 acre is within the highway right-of-way.

The basis for bearings is the north line of the southwest quarter of Section 15, being S 87°-00'-35"E, and all other bearings are from angles and distances measured in a field survey by Lee Surveying and Mapping Co., Inc. on August 14, 2007.



ORIGINAL STAMP IN GREEN

Description prepared by:

William K. Bruce
Professional Surveyor 7437
August 15, 2007

4493087

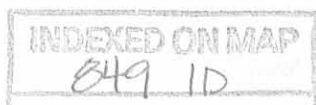

REC'D 8-17-07 SML/OK

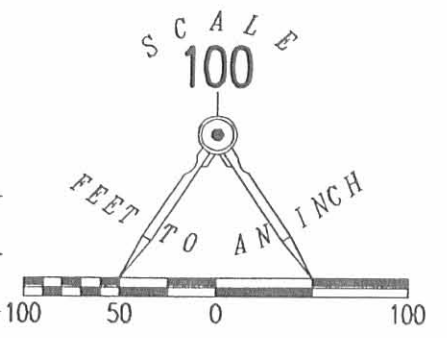
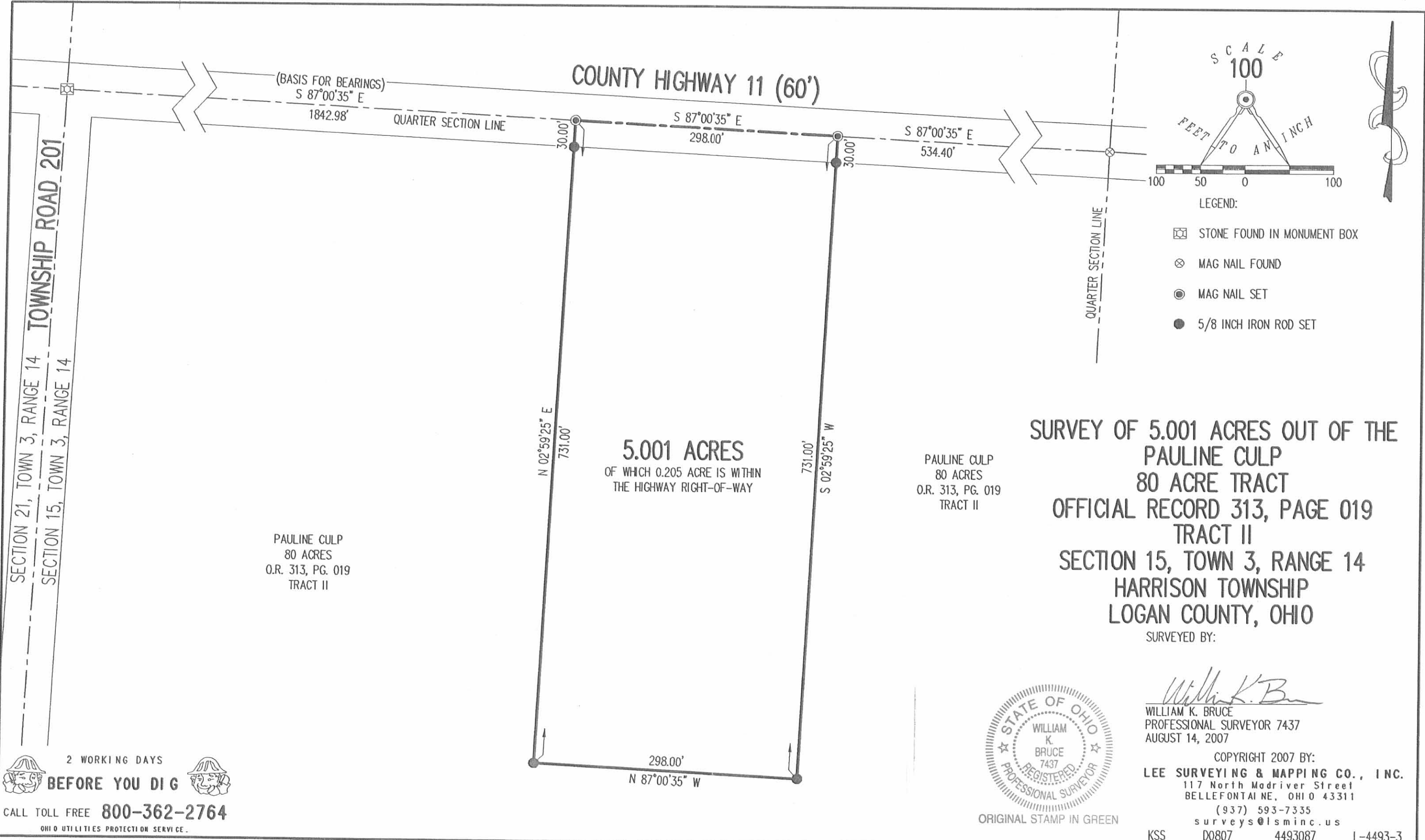

- LEGEND:
- ☒ STONE FOUND IN MONUMENT BOX
 - ⊗ MAG NAIL FOUND
 - ⊙ MAG NAIL SET
 - 5/8 INCH IRON ROD SET

SECTION 21, TOWN 3, RANGE 14
 SECTION 15, TOWN 3, RANGE 14
TOWNSHIP ROAD 201

PAULINE CULP
80 ACRES
O.R. 313, PG. 019
TRACT II

5.001 ACRES
OF WHICH 0.205 ACRE IS WITHIN
THE HIGHWAY RIGHT-OF-WAY

PAULINE CULP
80 ACRES
O.R. 313, PG. 019
TRACT II

**SURVEY OF 5.001 ACRES OUT OF THE
PAULINE CULP
80 ACRE TRACT
OFFICIAL RECORD 313, PAGE 019
TRACT II
SECTION 15, TOWN 3, RANGE 14
HARRISON TOWNSHIP
LOGAN COUNTY, OHIO**

SURVEYED BY:

William K. Bruce
WILLIAM K. BRUCE
PROFESSIONAL SURVEYOR 7437
AUGUST 14, 2007



ORIGINAL STAMP IN GREEN

COPYRIGHT 2007 BY:
LEE SURVEYING & MAPPING CO., INC.
117 North Madriver Street
BELLEFONTAINE, OHIO 43311
(937) 593-7335
surveys@lsminc.us
KSS D0807 4493087 L-4493-3

2 WORKING DAYS
BEFORE YOU DIG
CALL TOLL FREE **800-362-2764**
OHIO UTILITIES PROTECTION SERVICE.

INDEXED ON MAP
849 1P



RD 5-2-06 SMY OK

EDWARDS SURVEYING
110 SOUTH MAIN STREET
URBANA, OHIO 43078
(937) 653-6508

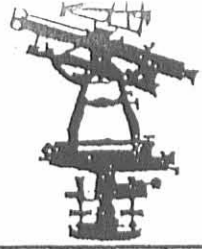

LEGAL DESCRIPTION FOR CULP'S 2.194 ACRE TRACT

Being situate in the State of Ohio, County of Logan, Township of Harrison and being a part of Section 15, Town 3, Range 14, B.T.M.R.S., and being more particularly described as follows:

Beginning for reference at a stone monument found in a monument box at the intersection of the centerlines of Township Road 201 (60' right-of-way) and County Road 11 (60' right-of-way);

thence with the centerline of County Road 11 and the quarter section line of Section 15, S-87°00'35"-E, 2545.46' (feet) to a Mag nail set at the PRINCIPLE PLACE OF BEGINNING for the tract hereinafter described;

thence continuing with the centerline of County Road 11 and the quarter section line of Section 15, S-87°00'35"-E, 230.00' (feet) to a Mag nail set, passing for reference a Mag nail found on the quarter section line of Section 15 at 130.00' (feet), said Mag nail found also being at the Northwest corner of a 20 acre tract conveyed to Pauline Culp, et al., by Deed recorded in Official Record 313, Page 19, Tract III, and at the Northeast corner of an 80 acre tract also conveyed to Pauline Culp, et al., by Deed recorded in Official Record 313, Page 19, Tract II, of the Logan County Records;

thence S-2°59'04"-W, 861.42' (feet) to an iron bar set on the North line of a 30 acre tract conveyed to Jean Ann Toriello by Deed recorded in Official Record 439, Page 703, of the Logan County Records, passing for reference an iron bar set on the right-of-way line of County Road 11 at 30.00' (feet);

thence with the North line of said Toriello's 30 acre tract, N-87°00'35"-W, 100.00' (feet) to a 5/8" diameter iron bar with "Edwards" cap found at the Northwest corner of said Toriello' tract and being on the East line of aforementioned Culp's 80 acre tract;

thence with the quarter section line of Section 15, the East line of said Culp's 80 acre tract, and the West line of aforementioned Culp's 20 acre tract, N-2°59'04"-E, 716.42' (feet) to an iron bar set;

thence N-38°53'27"-W, 194.75' (feet) to the place of beginning, passing for reference an iron bar set on the right-of-way line of County Road 11 at 154.46' (feet).

Containing a total of 2.194 acres, 0.149 acre of which is within the road right-of-way, but being subject to the rights of all legal highways and all easements of record.

The herein described tract is to be attached to mentioned and adjoining Toriello's 30 acre tract and is not to be used as a separate and independent parcel.

Being 0.216 acre out of an 80 acre tract conveyed to Pauline Culp, et al., by Deed recorded in Official Record 313, Page 19, Tract II, and 1.978 acres out of a 20 acre tract also conveyed to Pauline Culp by Deed recorded in Official Record 313, Page 19, Tract III, of the Logan County Records.

The foregoing description prepared by and in accordance with a Survey by William D. Edwards, Professional Surveyor No. 7574, April 26, 2006. All iron bars set are 5/8"x30" iron re-bar with a yellow plastic cap stamped "EDWARDS PS 4792 PS 7574". The basis of bearings for the herein described tract is the centerline of County Road 11 per an assumed bearing of S-87°00'35"-E.



William D. Edwards

William D. Edwards
Professional Surveyor No. 7574



REC'D 5-2-06 SMY OK

PLAT OF SURVEY

HARRISON TOWNSHIP, LOGAN COUNTY, OHIO
SECTION 15, TOWN 3, RANGE 14, B.T.M.R.S..

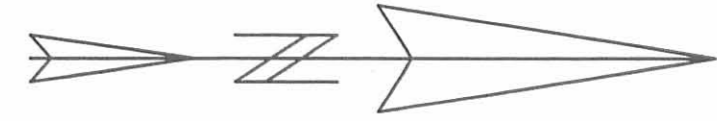

SCALE: 1" = 100'
-50 0 50 100 150

DATE: APRIL 26, 2006

TOWNSHIP ROAD 201

SECTION LINE 60' R/W

SEC-21

(FD.) IN MONUMENT BOX
0.8' BELOW GRADE

SEC-21

SEC-15

SEC-15

QUARTER SECTION LINE
COUNTY ROAD 11

S 87°00'35"E 2545.46'

NOTE:

1. BEARINGS ARE BASED ON THE CENTERLINE OF COUNTY ROAD 11 PER AN ASSUMED BEARING OF S-87°00'35"-E.
2. THE HEREON SHOWN 2.194 ACRE TRACT IS TO BE ATTACHED TO TORIELLO'S ADJOINING 30 AC. PARCEL.
3. REFERENCES USED: DEED OF SUBJECT PREMISES, DEEDS OF ADJOINING PARCELS, COUNTY TAX AND AERIAL MAPS, PLATS OF SURVEYS IN THE VICINITY.

LEGEND

- = IRON BAR.....FOUND
- ◻ = STONE MONUMENT.....FOUND
- ◻ = MAG NAIL.....FOUND
- = MAG NAIL.....SET at grade
- = 5/8"x30" IRON RE-BAR WITH YELLOW PLASTIC CAP STAMPED "EDWARDS PS 4792 PS 7574".....SET at grade

INDEXED ON MAP
849 JP

PAULINE CULP, ETAL
80 AC.
O.R. 313, P. 19
TRACT II

PAULINE CULP, ETAL
PT. 80 AC.
PT. O.R. 313, P. 19
TRACT II

PAULINE CULP, ETAL
PT. 20 AC.
PT. O.R. 313, P. 19
TRACT III
(1.978 AC.)

PAULINE CULP, ETAL
20 AC.
O.R. 313, P. 19
TRACT III

JEAN ANN TORIELLO
30 AC.
O.R. 439, P. 703

5/8" DIA.
W"EDWARDS" CAP

QUARTER SECTION LINE

10' GRAVEL DRIVEWAY

N 87°00'35"W
100.00'

N 2°59'04"E 716.42'

2.194 AC.
(0.149 AC. R/W)
(2.045 AC. NET)

S 2°59'04"W 861.42'

N 38°53'27"W
194.75'

(0.216 AC.)

145.00'

40.29'

60' R/W

130.00'

S 87°00'35"E, 230.00'

100.00'

30.00'

R/W

R/W



SURVEYED BY: *William D. Edwards*
WILLIAM D. EDWARDS
PROFESSIONAL SURVEYOR No. 7574
110 SOUTH MAIN STREET
URBANA, OHIO 43078
(937)653-6508

849 3D

Andrew Culp's Road.

Harrison Twp
Sec 15 T 3 R 14

The following described land situated in the NE quarter of the SW quarter of Sec. 15, Town 3, Range 14, Harrison Township, Logan County, Ohio.

Beginning at the northeast corner of the southwest quarter of Sec. 15, Town 3, Range 14, in the center of the Silver Lake Pike, and also the southeast corner of Amos O. Alexanders land.

Thence S $5^{\circ}13'$ W with the west line of a Township road and East line of Andrew J. Culp's 80 acre tract 105 feet to a harrow tooth.

Thence N 45° W 159 feet to a harrow tooth in the center of the Silver Lake Pike.

Thence S $86^{\circ}20'$ E with the center of said pike 122 $\frac{1}{2}$ feet to the place of beginning.

Containing .15 of an acre.

Field Notes Book 86 Page 8

Lee Surveying and Mapping Co., Inc.

Land Surveys • Topography • Subdivisions • Construction Layout

117 N. Madriver St.
Bellefontaine OH 43311



Phone: (937) 593-7335
Fax: (937) 593-7444
surveys@lsminc.us

SAXTON, TORIELLO AND CULP TRACT I 49.176 ACRES

Lying in Sections 14 and 15, Town 3, Range 14, Union and Harrison Township, Logan County, Ohio.

Being out of the Shirley M. Saxton, Jean A. Toriello and Jack E. Culp 50 acre tract and 74.783 acre tract as deeded and described in Official Record 1037, Page 471, Tract I and Tract II of the Logan County Records of Deeds and being more particularly described as follows:

Commencing on a stone found in a monument box on the west line of Section 15 at the intersection of the center-lines of Township Road 201 and County Highway 11.

THENCE, with the north line of the southwest quarter of Section 15 and the center-line of County Highway 11 (60 feet wide), S 87°-00'-53"E, a distance of 1333.64 feet to a MAG nail set at the TRUE POINT OF BEGINNING.

THENCE, with the north line of the southwest quarter of Section 15 and the center-line of County Highway 11, S 87°-00'-53"E, a distance of 509.34 feet to a MAG nail found.

THENCE, with the lines of the Culp Family Limited Partnership 5.001 acre tract (O.R. 942, Pg. 692), the following two courses:

S 02°-59'-25"W, a distance of 731.00 feet to a 5/8 inch iron rod found, passing a 5/8 inch iron rod found at 30.00 feet.

S 87°-00'-53"E, a distance of 186.00 feet to a 5/8 inch iron rod set.

THENCE, S 03°-02'-14"W, a distance of 1493.12 feet to a 5/8 inch iron rod set.

THENCE, S 87°-00'-53"E, a distance of 648.73 feet to a 5/8 inch iron rod set on the east line of the southwest quarter of Section 15.

THENCE, with the east line of the southwest quarter of Section 15 and the west line of the Emil Toriello 30.608 acre tract (O.R. 1005, Pg. 832, Tract II), S 02°-57'-42"W, a distance of 449.75 feet to a 1.3 feet by 1.3 feet concrete post found on the south line of Section 15 and Harrison Township and the north line of Section 14 and Union Township, passing a 5/8 inch iron rod found at 444.75 feet.

Lee Surveying and Mapping Co., Inc.

Land Surveys • Topography • Subdivisions • Construction Layout

117 N. Madriver St.
Bellefontaine OH 43311



Phone: (937) 593-7335
Fax: (937) 593-7444
surveys@lsminc.us

THENCE, with the east line of the northwest quarter of Section 14 and the west line of the Suzanne E. Holycross 7.66 acre tract (O.R. 655, Pg. 873), S 02°-42'-00"W, a distance of 438.15 feet to a 5/8 inch iron rod set.

THENCE, N 87°-17'-11"W, a distance of 997.43 feet to a 5/8 inch iron rod set.

THENCE, N 02°-45'-08"E, passing the north line of Section 14 and Union Township and the south line of Section 15 and Harrison Township, a distance of 1330.18 feet to a 5/8 inch iron rod set.

THENCE, N 88°-14'-26"W, a distance of 334.97 feet to a 5/8 inch iron rod set.

THENCE, with the east line of the Culp Family Limited Partnership 77.566 acre tract (O.R. 937, Pg. 941), N 02°-45'-08"E, a distance of 1793.76 feet to the point of beginning, passing a 5/8 inch iron rod set at 1763.76 feet.

Containing 49.176 acres, of which 0.352 acre is within the highway right-of-way.

There are 10.031 acres in Union Township and 39.145 acres in Harrison Township.

Property is subject to any and all previous easements and rights-of-way of record.

The basis for bearings is south line of Section 15, being S 87°-17'-11"E, and all other bearings are from angles and distances measured in a field survey by Lee Surveying and Mapping Co., Inc. on November 7, 2011.

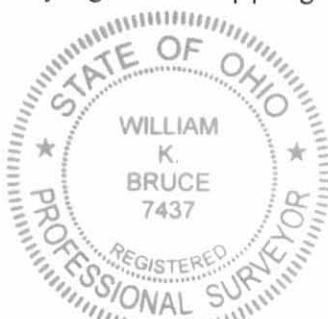

ORIGINAL STAMP IN GREEN

Description prepared by:

William K. Bruce

William K. Bruce
Professional Surveyor 7437
November 8, 2011
Revised December 6, 2011

44930811



Lee Surveying and Mapping Co., Inc.

Land Surveys • Topography • Subdivisions • Construction Layout

117 N. Madriver St.
Bellefontaine OH 43311



Phone: (937) 593-7335
Fax: (937) 593-7444
surveys@lsminc.us

SAXTON, TORIELLO AND CULP TRACT II 49.176 ACRES

Lying in Sections 14 and 15, Town 3, Range 14, Union and Harrison Township, Logan County, Ohio.

Being out of the Shirley M. Saxton, Jean A. Toriello and Jack E. Culp 50 acre tract and 74.783 acre tract as deeded and described in Official Record 1037, Page 471, Tract I and Tract II of the Logan County Records of Deeds and being more particularly described as follows:

Commencing on a stone found on the northwest corner of Section 14 and north line of Union Township and the southwest corner of Section 15 and the south line of Harrison Township on the center-line of Township Road 201.

THENCE, with the north line of Section 14 and Union Township and the south lines of Section 15 and Harrison Township and the Culp Family Limited Partnership 77.566 acre tract (O.R. 937, Pg. 941), S 87°-17'-11"E, a distance of 981.95 feet to a 5/8 inch iron rod set at the TRUE POINT OF BEGINNING.

THENCE, with the north line of Section 14 and Union Township and the south lines of Section 15 and Harrison Township and the said 77.566 acre tract, S 87°-17'-11"E, a distance of 351.68 feet to a 5/8 inch iron rod set.

THENCE, with the west line of the said 77.566 acre tract, N 02°-45'-08"E, a distance of 886.45 feet to a 5/8 inch iron rod set.

THENCE, S 88°-14'-26"E, a distance of 334.97 feet to a 5/8 inch iron rod set.

THENCE, S 02°-45'-08"W, passing the south line of Section 15 and Harrison Township and the north line of Section 14 and Union Township, a distance of 1330.18 feet to a 5/8 inch iron rod set.

THENCE, S 87°-17'-11"E, a distance of 997.43 feet to a 5/8 inch iron rod set on the east line of the northwest quarter of Section 14.

THENCE, with the east line of the northwest quarter of Section 14 and the west line of the Suzanne E. Holycross 7.66 acre tract (O.R. 655, Pg. 873), S 02°-42'-00"W, a distance of 897.28 feet to a 5/8 inch iron rod found within the right-of-way of Township Road 200, passing a 5/8 inch iron rod set at 563.19 feet.

THENCE, within the right-of-way of Township Road 200 (60 feet wide), N 87°-09'-33"W, a distance of 1737.66 feet to a railroad spike found.

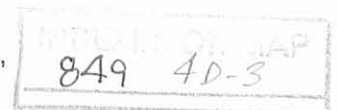

Lee Surveying and Mapping Co., Inc.

Land Surveys • Topography • Subdivisions • Construction Layout

117 N. Madriver St.
Bellefontaine OH 43311



Phone: (937) 593-7335
Fax: (937) 593-7444
surveys@lsminc.us

THENCE, with the east line of the Jack Emery Culp 30.00 acre tract (Vol. 365, Pg. 230), N 05°-01'-23"E, a distance of 1332.66 feet to the point of beginning, passing a 5/8 inch iron rod set at 30.02 feet.

Containing 49.176 acres, of which 1.537 acres are within the highway right-of-way.

There are 42.339 acres in Union Township and 6.837 acres in Harrison Township.

Property is subject to any and all previous easements and rights-of-way of record.

The basis for bearings is south line of Section 15, being S 87°-17'-11"E, and all other bearings are from angles and distances measured in a field survey by Lee Surveying and Mapping Co., Inc. on November 7, 2011.



ORIGINAL STAMP IN GREEN

Description prepared by:

A handwritten signature in black ink that reads 'William K. Bruce'.

William K. Bruce
Professional Surveyor 7437
November 8, 2011
Revised December 6, 2011

44930811

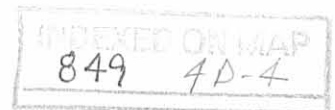

Lee Surveying and Mapping Co., Inc.

Land Surveys • Topography • Subdivisions • Construction Layout

117 N. Madriver St.
Bellefontaine OH 43311

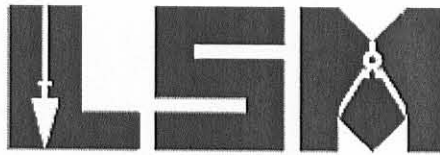

Phone: (937) 593-7335
Fax: (937) 593-7444
surveys@lsminc.us

SAXTON, TORIELLO AND CULP 30.958 ACRES

Lying in Section 15, Town 3, Range 14, Harrison Township, Logan County, Ohio.

Being out of the Shirley M. Saxton, Jean A. Toriello and Jack E. Culp 74.783 acre tract as deeded and described in Official Record 1037, Page 471, Tract II of the Logan County Records of Deeds and being more particularly described as follows:

Commencing on a MAG nail found on the northeast corner of the southwest quarter of Section 15 on the center-line of County Highway 11.

THENCE, with the north line of the southwest quarter of Section 15 and the center-line of County Highway 11 (60 feet wide), N 87°-00'-53"W, a distance of 130.00 feet to a MAG nail found at the TRUE POINT OF BEGINNING.

THENCE, with the westerly line of the Emil Toriello 2.194 acre tract (O.R. 1005, Pg. 832, Tract I), S 38°-54'-20"E, a distance of 194.78 feet to a 5/8 inch iron rod found on the east line of the southwest quarter of Section 15, passing a 5/8 inch iron rod found at 40.31 feet.

THENCE, with the east line of the southwest quarter of Section 15 and the west lines of the said 2.194 acre tract and the Emil Toriello 30.608 acre tract (O.R. 1005, Pg. 832, Tract II), S 02°-57'-42"W, a distance of 2079.12 feet to a 5/8 inch iron rod set, passing a 5/8 inch iron rod found at 715.93 feet.

THENCE, N 87°-00'-53"W, a distance of 648.73 feet to a 5/8 inch iron rod set.

THENCE, N 03°-02'-14"E, a distance of 1493.12 feet to a 5/8 inch iron rod set.

THENCE, with the lines of the Culp Family Limited Partnership 5.001 acre tract (O.R. 942, Pg. 692), the following two courses:

S 87°-00'-53"E, a distance of 112.00 feet to a 5/8 inch iron rod found.

N 02°-59'-25"E, a distance of 731.00 feet to a MAG nail found on the north line of the southwest quarter of Section 15 and the center-line of County Highway 11, passing a 5/8 inch iron rod found at 701.00 feet.

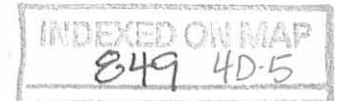

Lee Surveying and Mapping Co., Inc.

Land Surveys • Topography • Subdivisions • Construction Layout

117 N. Madriver St.
Bellefontaine OH 43311



Phone: (937) 593-7335
Fax: (937) 593-7444
surveys@lsminc.us

THENCE, with the north line of the southwest quarter of Section 15 and the center-line of County Highway 11, S 87°-00'-53"E, a distance of 404.40 feet to the point of beginning.

Containing 30.958 acres, of which 0.289 acre is within the highway right-of-way.

Property is subject to any and all previous easements and rights-of-way of record.

The basis for bearings is south line of Section 15, being S 87°-17'-11"E, and all other bearings are from angles and distances measured in a field survey by Lee Surveying and Mapping Co., Inc. on November 7, 2011.

Description prepared by:

A handwritten signature in black ink that reads "William K. Bruce". The signature is written in a cursive, flowing style.

William K. Bruce
Professional Surveyor 7437
November 8, 2011



44930811

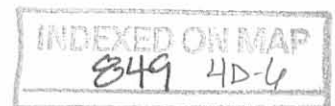

Lee Surveying and Mapping Co., Inc.

Land Surveys • Topography • Subdivisions • Construction Layout

117 N. Madriver St.
Bellefontaine OH 43311

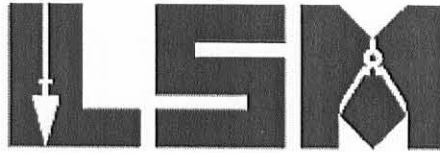

Phone: (937) 593-7335
Fax: (937) 593-7444
surveys@lsmc.us

SAXTON, TORIELLO AND CULP 18.218 ACRES

Lying in Section 15, Town 3, Range 14, Harrison Township, Logan County, Ohio.

Being all of the Shirley M. Saxton, Jean A. Toriello and Jack E. Culp 18.022 acre tract as deeded and described in Official Record 1037, Page 471, Tract III of the Logan County Records of Deeds and being more particularly described as follows:

Commencing on a MAG nail found on the northwest corner of the southeast quarter of Section 15 on the center-line of County Highway 11.

THENCE, with the north line of the southeast quarter of Section 15 and the center-line of County Highway 11 (60 feet wide), S 87°-02'-13"E, a distance of 100.00 feet to a MAG nail found at the TRUE POINT OF BEGINNING.

THENCE, with the north line of the southeast quarter of Section 15 and the center-line of County Highway 11, S 87°-02'-13"E, a distance of 877.84 feet to a 3/4 inch iron rod found.

THENCE, with the north line of the southeast quarter of Section 15 and the south line of the Billy W. Gillenwater 0.9875 acre tract (O.R. 57, Pg. 246) and within the right-of-way of County Highway 11, S 87°-02'-13"E, a distance of 42.98 feet to a 5/8 inch iron rod set, passing a 5/8 inch iron rod set at 30.00 feet.

THENCE, with the west line of the John T. Belser II, 52.859 acre tract (O.R. 689, Pg. 295), S 02°-52'-21"W, a distance of 861.41 feet to a 5/8 inch iron rod found.

THENCE, with the north line of the Emil Toriello 30.608 acre tract (O.R. 1005, Pg. 832, Tract II), N 87°-00'-34"W, a distance of 922.16 feet to a 5/8 inch iron rod set.

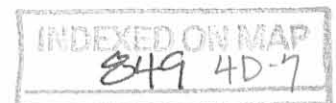

Lee Surveying and Mapping Co., Inc.

Land Surveys • Topography • Subdivisions • Construction Layout

117 N. Madriver St.
Bellefontaine OH 43311



Phone: (937) 593-7335
Fax: (937) 593-7444
surveys@lsminc.us

THENCE, with the east line of the Emil Toriello 2.194 acre tract (O.R. 1005, Pg. 832, Tract I), N 02°-57'-42"E, a distance of 860.97 feet to the point of beginning, passing a 5/8 inch iron rod found at 830.99 feet.

Containing 18.218 acres, of which 0.625 acre is within the highway right-of-way.

Property is subject to any and all previous easements and rights-of-way of record.

The basis for bearings is south line of Section 15, being S 87°-17'-11"E, and all other bearings are from angles and distances measured in a field survey by Lee Surveying and Mapping Co., Inc. on November 7, 2011.

Description prepared by:



ORIGINAL STAMP IN GREEN

William K. Bruce
Professional Surveyor 7437
November 8, 2011

44930811

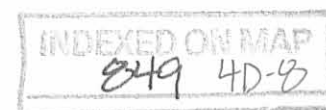

REV'D 11-14-11 SMY/OC

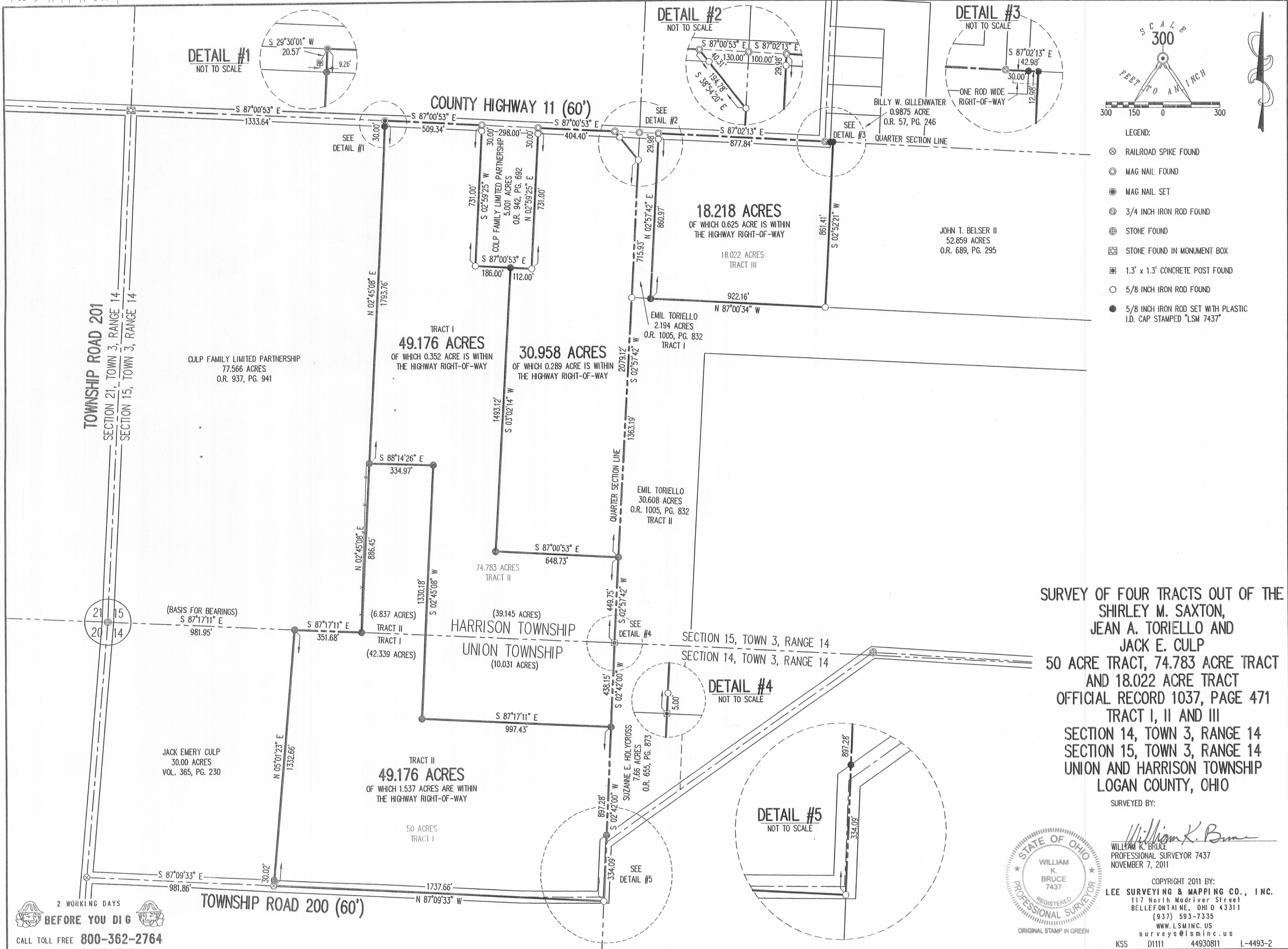

SURVEY OF FOUR TRACTS OUT OF THE SHIRLEY M. SAXTON, JEAN A. TORIELLO AND JACK E. CULP 50 ACRE TRACT, 74.783 ACRE TRACT AND 18.022 ACRE TRACT OFFICIAL RECORD 1037, PAGE 471 TRACT I, II AND III SECTION 14, TOWN 3, RANGE 14 SECTION 15, TOWN 3, RANGE 14 UNION AND HARRISON TOWNSHIP LOGAN COUNTY, OHIO

SURVEYED BY:
William K. Bruce



WILLIAM K. BRUCE
PROFESSIONAL SURVEYOR 7437
NOVEMBER 7, 2011

COPYRIGHT 2011 BY:
LEE SURVEYING & MAPPING CO., INC.
117 North Medriver Street
BELLEFONTAINE, OHIO 43111
(937) 593-7335
WWW.LSMINC.US
surveys@lsminc.us

KSS D1111 44930811 L-4493-2

2 WORKING DAYS
BEFORE YOU DIG
CALL TOLL FREE 800-362-2764
OHIO UTILITY PROTECTION SERVICE

INDEXED ON MAP
849 4P

REC'D 1-27-12 SMY OK

Lee Surveying and Mapping Co., Inc.

Land Surveys • Topography • Subdivisions • Construction Layout

117 N. Madriver St.
Bellefontaine OH 43311

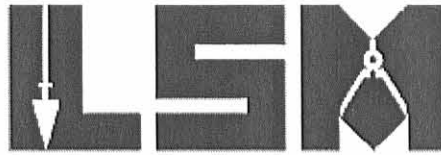

Phone: (937) 593-7335
Fax: (937) 593-7444
surveys@lsminc.us

BROWN AND CRONIN 24.588 ACRES TRACT A

Lying in Section 15, Town 3, Range 14, Harrison Township, Logan County, Ohio.

Being out of the Elizabeth A. Brown and Lisa J. Cronin 49.176 acre tract as deeded and described in Official Record 1052, Page 549 of the Logan County Records of Deeds and being more particularly described as follows:

Commencing on a stone found in a monument box on the west line of Section 15 at the intersection of the center-lines of Township Road 201 and County Highway 11.

THENCE, with the north line of the southwest quarter of Section 15 and the center-line of County Highway 11 (60 feet wide), S 87°-00'-53"E, a distance of 1333.64 feet to a MAG nail found at the TRUE POINT OF BEGINNING.

THENCE, with the north line of the southwest quarter of Section 15 and the center-line of County Highway 11, S 87°-00'-53"E, a distance of 509.34 feet to a MAG nail found.

THENCE, with the lines of the Culp Family Limited Partnership 5.001 acre tract (O.R. 942, Pg. 692), the following two courses:

S 02°-59'-25"W, a distance of 731.00 feet to a 5/8 inch iron rod found, passing a 5/8 inch iron rod found at 30.00 feet.

S 87°-00'-53"E, a distance of 186.00 feet to a 5/8 inch iron rod found.

THENCE, with the west line of the Douglas J. Corwin 30.958 acre tract (O.R. 1052, Pg. 545), S 03°-02'-14"W, a distance of 888.73 feet to a 5/8 inch iron rod set.

THENCE, S 67°-38'-29"W, a distance of 389.80 feet to a 5/8 inch iron rod found.

THENCE, with a north line of the Jack E. Culp 49.176 acre tract (O.R. 1052, Pg. 557), N 88°-14'-26"W, a distance of 334.97 feet to a 5/8 inch iron rod found.

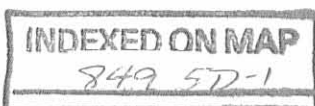

Lee Surveying and Mapping Co., Inc.

Land Surveys • Topography • Subdivisions • Construction Layout

117 N. Madriver St.
Bellefontaine OH 43311

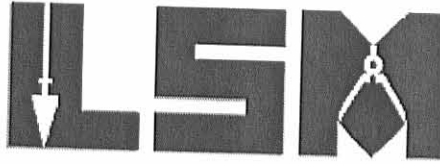

Phone: (937) 593-7335
Fax: (937) 593-7444
surveys@lsminc.us

THENCE, with the east line of the Culp Family Limited Partnership 77.566 acre tract (O.R. 937, Pg. 941), N 02°-45'-08"E, a distance of 1793.76 feet to the point of beginning, passing a 5/8 inch iron rod found at 1763.76 feet.

Containing 24.588 acres, of which 0.352 acre is within the highway right-of-way.

Property is subject to any and all previous easements and rights-of-way of record.

The basis for bearings is the north line of the southwest quarter of Section 15, being S 87°-00'-53"E, and all other bearings are from angles and distances measured in a field survey by Lee Surveying and Mapping Co., Inc. on January 25, 2012.



ORIGINAL STAMP IN GREEN

Description prepared by:

A handwritten signature in cursive script that reads 'William K. Bruce'.

William K. Bruce
Professional Surveyor 7437
January 25, 2012

44930112

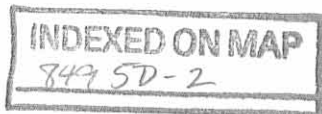

REC'D 1-27-12 SWM OK

Lee Surveying and Mapping Co., Inc.

Land Surveys • Topography • Subdivisions • Construction Layout

117 N. Madriver St.
Bellefontaine OH 43311



Phone: (937) 593-7335
Fax: (937) 593-7444
surveys@lsminc.us

BROWN AND CRONIN 24.588 ACRES TRACT B

Lying in Sections 14 and 15, Town 3, Range 14, Union and Harrison Township, Logan County, Ohio.

Being out of the Elizabeth A. Brown and Lisa J. Cronin 49.176 acre tract as deeded and described in Official Record 1052, Page 549 of the Logan County Records of Deeds and being more particularly described as follows:

Commencing on a stone found in a monument box on the west line of Section 15 at the intersection of the center-lines of Township Road 201 and County Highway 11.

THENCE, with the north line of the southwest quarter of Section 15 and the center-line of County Highway 11 (60 feet wide), S 87°-00'-53"E, a distance of 1333.64 feet to a MAG nail found.

THENCE, with the east line of the Culp Family Limited Partnership 77.566 acre tract (O.R. 937, Pg. 941), S 02°-45'-08"W, a distance of 1793.76 feet to a 5/8 inch iron rod found, passing a 5/8 inch iron rod found at 30.00 feet.

THENCE, with a north line of the Jack E. Culp 49.176 acre tract (O.R. 1052, Pg. 557), S 88°-14'-26"E, a distance of 334.97 feet to a 5/8 inch iron rod found at the TRUE POINT OF BEGINNING.

THENCE, N 67°-38'-29"E, a distance of 389.80 feet to a 5/8 inch iron rod set.

THENCE, with the lines of the Douglas J. Corwin 30.958 acre tract (O.R. 1052, Pg. 545), the following two courses:

S 03°-02'-14"W, a distance of 604.39 feet to a 5/8 inch iron rod found

S 87°-00'-53"E, a distance of 648.73 feet to a 5/8 inch iron rod found on the east line of the southwest quarter of Section 15.

THENCE, with the east line of the southwest quarter of Section 15 and the west line of the Emil Toriello 30.608 acre tract (O.R. 1005, Pg. 832, Tract II), S 02°-57'-42"W, a distance of 449.75 feet to a 1.3 feet by 1.3 feet concrete post found on the south line of Section 15 and Harrison Township and the north line of Section 14 and Union Township, passing a 5/8 inch iron rod found at 444.75 feet.

INDEXED ON MAP
849 5D-3

Lee Surveying and Mapping Co., Inc.

Land Surveys • Topography • Subdivisions • Construction Layout

117 N. Madriver St.
Bellefontaine OH 43311



Phone: (937) 593-7335
Fax: (937) 593-7444
surveys@lsminc.us

THENCE, with the east line of the northwest quarter of Section 14 and the west line of the Suzanne E. Holycross 7.66 acre tract (O.R. 655, Pg. 873), S 02°-42'-00"W, a distance of 438.15 feet to a 5/8 inch iron rod found.

THENCE, with the lines of the aforesaid Culp 49.176 acre tract, the following two courses:

N 87°-17'-11"W, a distance of 997.43 feet to a 5/8 inch iron rod found.

N 02°-45'-08"E, passing the north line of Section 14 and Union Township and the south line of Section 15 and Harrison Township, a distance of 1330.18 feet to the point of beginning.

Containing 24.588 acres.

Property is subject to any and all previous easements and rights-of-way of record.

This tract is to only be attached to an adjoining parcel of land with road frontage.

The basis for bearings is the north line of the southwest quarter of Section 15, being S 87°-00'-53"E, and all other bearings are from angles and distances measured in a field survey by Lee Surveying and Mapping Co., Inc. on January 25, 2012.

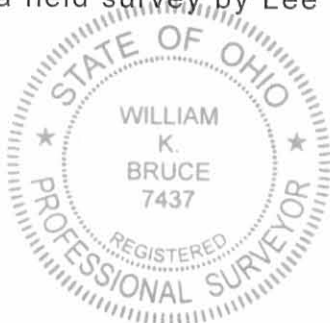

ORIGINAL STAMP IN GREEN

Description prepared by:

A handwritten signature in cursive script that reads 'William K. Bruce'.

William K. Bruce
Professional Surveyor 7437
January 25, 2012

44930112

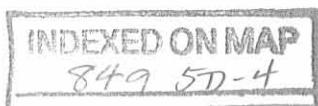

REC'D 1-27-12 SWM

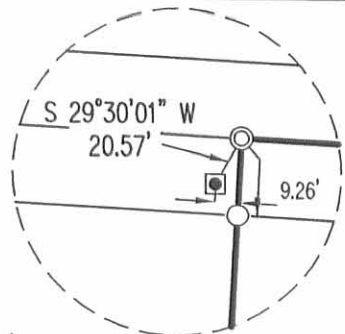

DETAIL #1
NOT TO SCALE

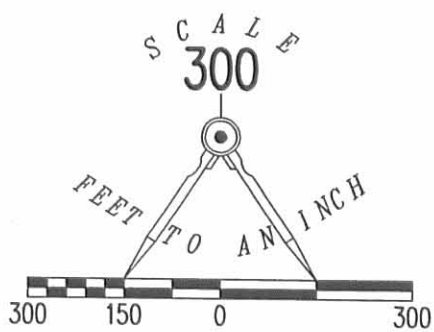

LEGEND:

- ⊙ MAG NAIL FOUND
- ⊕ STONE FOUND
- ⊗ STONE FOUND IN MONUMENT BOX
- ⊠ 1.3' x 1.3' CONCRETE POST FOUND
- 5/8 INCH IRON ROD FOUND
- 5/8 INCH IRON ROD SET WITH PLASTIC I.D. CAP STAMPED "LSM 7437"

COUNTY HIGHWAY 11 (60')
QUARTER SECTION LINE
S 87°00'53" E 1333.64'
S 87°00'53" E 509.34'

SECTION 21, TOWN 3, RANGE 14
SECTION 15, TOWN 3, RANGE 14
TOWNSHIP ROAD 201

CULP FAMILY LIMITED PARTNERSHIP
5.001 ACRES
O.R. 942, PG. 692

TRACT A
24.588 ACRES
OF WHICH 0.352 ACRE IS WITHIN
THE HIGHWAY RIGHT-OF-WAY

**SURVEY OF TWO TRACTS OUT OF THE
ELIZABETH A. BROWN AND
LISA J. CRONIN
49.176 ACRE TRACT
OFFICIAL RECORD 1052, PAGE 549
SECTION 14, TOWN 3, RANGE 14
SECTION 15, TOWN 3, RANGE 14
UNION AND HARRISON TOWNSHIP
LOGAN COUNTY, OHIO**

CULP FAMILY LIMITED PARTNERSHIP
77.566 ACRES
O.R. 937, PG. 941

DOUGLAS J. CORWIN
30.958 ACRES
O.R. 1052, PG. 545

EMIL TORIELLO
30.608 ACRES
O.R. 1005, PG. 832
TRACT II

TRACT B
24.588 ACRES
(14.557 ACRES)

HARRISON TOWNSHIP
UNION TOWNSHIP
(10.031 ACRES)

JACK E. CULP
49.176 ACRES
O.R. 1052, PG. 557

SUZANNE E. HOLYCROSS
7.66 ACRES
O.R. 655, PG. 873

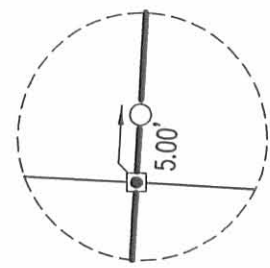

DETAIL #2
NOT TO SCALE

SURVEYED BY:

William K. Bruce

WILLIAM K. BRUCE
PROFESSIONAL SURVEYOR 7437
JANUARY 25, 2012



COPYRIGHT 2012 BY:
LEE SURVEYING & MAPPING CO., INC.
117 North Madriver Street
BELLEFONTAINE, OHIO 43311
(937) 593-7335
WWW.LSMINC.US
surveys@lsminc.us

NOTE:

TRACT B IS TO ONLY BE ATTACHED TO AN
ADJOINING PARCEL WITH ROAD FRONTAGE.

2 WORKING DAYS



CALL TOLL FREE **800-362-2764**

OHIO UTILITIES PROTECTION SERVICE

INDEXED ON MAP
849 SP

KSS D0112 44930112 L-4493-3



8-9-12
SMJ OK

EDWARDS SURVEYING
110 SOUTH MAIN STREET
URBANA, OHIO 43078
(937) 653-6508



LEGAL DESCRIPTION FOR TORIELLO'S 15.849 ACRE TRACT

Being situate in the State of Ohio, County of Logan, Township of Harrison and being a part of Section 15, Town 3, Range 14, B.T.M.R.S., and being more particularly described as follows:

Beginning for reference at a stone monument found in a monument box at the intersection of the centerlines of Township Road 201 and County Road 11 (60' right-of-way);

thence with the centerline of County Road 11 and the quarter line section of said Section 15, S-87°00'35"-E, 2675.46' (feet) to a Mag nail found on the quarter section line of said Section 15;

thence with said quarter section line, the West line of a 2.194 acre tract conveyed to Emil & Jean Ann Toriello by Deed recorded in Official Record 1005, Page 832, Tract 1, and the East line of a 30.958 acre tract conveyed to Gregory R. Culp by Deed recorded in Official Record 1057, Page 894, S-2°59'04"-W, 861.42' (feet) to a 5/8" diameter iron bar found at the Northwest corner of a 30.608 acre tract also conveyed to Emil & Jean Ann Toriello by Deed recorded in Official Record 1005, Page 832, Tract 2, of which the herein described parcel is a part of, passing for reference a 5/8" diameter iron bar found at a corner of said Toriello's 2.194 acre tract at 145.00' (feet);

thence S-87°00'35"-E, 100.00' (feet) to a 5/8" diameter iron bar found at the **PRINCIPLE PLACE OF BEGINNING** for the tract hereinafter described, said iron bar found being at the Southeast corner of said Toriello's 2.194 acre tract and at the Southwest corner of an 18.218 acre tract conveyed to Gregory R. Culp by Deed recorded in Official Record 1057, Page 894, of the Logan County Records;

thence with the South line of said Culp's 18.218 acre tract and with the South line of a 52.859 acre tract conveyed to John T. Belser II, et al., by Deed recorded in Official Record 689, Page 295, S-87°00'35"-E, 2573.85' (feet) to an iron anchor post found on the East line of Section 15 at a corner of said Belser's 52.859 acre tract, passing for reference a 5/8" diameter iron bar found at 2668.25' (feet);

thence with a West line of said Belser's 52.859 acre tract, the East line of said Section 15, also being the West line of Section 9, S-3°05'16"-W, 262.21' (feet) to a 5/8" diameter iron bar found at the Northeast corner of an 80.40 acre tract conveyed to Michael W. Holycross, et al., by Deed recorded in Official Record 827, Page 211, Parcel 1, of the Logan County Records;

thence with the North line of said Holycross' 80.40 acre tract and the North line thereof projected, N-87°16'55"-W, 2572.80' (feet) to an iron bar set, passing for reference a 5/8" diameter iron bar found at the Northwest corner of said Holycross' 80.40 acre tract at 2272.70' (feet);

thence N-2°59'00"-E, 274.43' (feet) to the place of beginning.

Containing 15.849 acres, but being subject to the rights of all legal highways and all easements of record.

Being a part of a 30.608 acre tract conveyed to Emil & Jean Ann Toriello by Deed recorded in Official Record 1005, Page 832, Tract 2, of the Logan County Records.

The herein described tract is to be attached to an adjoining parcel and is not to be used as a separate and independent tract.

The foregoing description prepared by and in accordance with a Survey by William D. Edwards, Professional Surveyor No. 7574, July 30, 2012. All iron bars set are 5/8"x30" iron re-bar with a yellow plastic cap stamped "EDWARDS PS 4792 PS 7574". The basis of bearings for the herein described tract is the South line of Harrison Township per Official Record 364, Page 536, of the Logan County Records (N-87°00'00"-W).

William D. Edwards
Professional Surveyor No. 7574



INDEXED ON MAP
849 6D-1

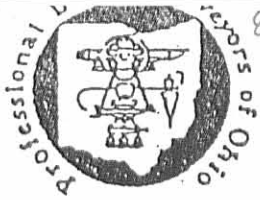

8-9-12
emy ac

EDWARDS SURVEYING
110 SOUTH MAIN STREET
URBANA, OHIO 43078
(937) 653-6508



LEGAL DESCRIPTION FOR TORIELLO'S 11.830 ACRE TRACT

Being situate in the State of Ohio, County of Logan, Township of Harrison and being a part of Section 15, Town 3, Range 14, B.T.M.R.S., and being more particularly described as follows:

Beginning for reference at a stone monument found in a monument box at the intersection of the centerlines of Township Road 201 and County Road 11 (60' right-of-way);

thence with the centerline of County Road 11 and the quarter section line of said Section 15, S-87°00'35"-E, 2675.46' (feet) to a Mag nail found on the quarter section line of said Section 15;

thence with said quarter section line, the West line of a 2.194 acre tract conveyed to Emil & Jean Ann Toriello by Deed recorded in Official Record 1005, Page 832, Tract 1, and the East line of a 30.958 acre tract conveyed to Gregory R. Culp by Deed recorded in Official Record 1057, Page 894, S-2°59'04"-W, 861.42' (feet) to a 5/8" diameter iron bar found at the Northwest corner of a 30.608 acre tract also conveyed to Emil & Jean Ann Toriello by Deed recorded in Official Record 1005, Page 832, Tract 2, of which the herein described parcel is a part of, passing for reference a 5/8" diameter iron bar found at a corner of said Toriello's 2.194 acre tract at 145.00' (feet);

thence continuing with the quarter section line of said Section 15, the West line of said Toriello's 30.608 acre tract and the East line of said Culp's 30.958 acre tract, S-2°59'04"-W, 517.64' (feet) to an iron bar set at the **PRINCIPLE PLACE OF BEGINNING** for the tract hereinafter described;

thence S-85°09'48"-E, 400.31' (feet) to an iron bar set on the West line of an 80.40 acre tract conveyed to Michael W. Holycross, et al., by Deed recorded in Official Record 827, Page 211, Parcel 1, of the Logan County Records;

thence with the West line of said Holycross' 80.40 acre tract, S-2°59'04"-W, 1281.59' (feet) to a 5/8" diameter iron bar found on the South line of said Section 15, also being the North line of Section 14, also being on the South line of Harrison Township, and the North line of Union Township, and being at the Northeast corner of a 7.66 acre tract conveyed to Suzanne E. Holycross by Deed recorded in Official Record 655, Page 873, of the Logan County Records;

thence with the North line of said Holycross' 7.66 acre tract, the North line of Section 14, the North line of Union Township, the South line of said Section 15, and the South line of Harrison Township, N-87°00'00"-W, 400.10' (feet) to a 1.3'x1.3' concrete post found on the East line of a 24.588 acre tract conveyed to Gregory R. Culp by Deed recorded in Official Record 1057, Page 892, of the Logan County Records;

thence with the East line of said Culp's 24.588 acre tract, the East line of aforementioned Culp's 30.958 acre tract, and the quarter section line of Section 15, N-2°59'04"-E, 1294.42' (feet) to the place of beginning, passing for reference a 5/8" diameter iron bar found at 5.00' (feet) and also passing for reference a 5/8" diameter iron bar found at the Southeast corner of said Culp's 30.958 acre tract at 449.75' (feet).

Containing 11.830 acres, but being subject to the rights of all legal highways and all easements of record.

Being a part of a 30.608 acre tract conveyed to Emil & Jean Ann Toriello by Deed recorded in Official Record 1005, Page 832, Tract 2, of the Logan County Records.

The herein described tract is to be attached to an adjoining parcel and is not to be used as a separate and independent tract.

The foregoing description prepared by and in accordance with a Survey by William D. Edwards, Professional Surveyor No. 7574, July 30, 2012. All iron bars set are 5/8"x30" iron re-bar with a yellow plastic cap stamped "EDWARDS PS 4792 PS 7574". The basis of bearings for the herein described tract is the South line of Harrison Township per Official Record 364, Page 536, of the Logan County Records (N-87°00'00"-W).

William D. Edwards
Professional Surveyor No. 7574



INDEXED ON MAP
849 GD-2

REC'D 8-9-12 GMM/ML

PLAT OF SURVEY

HARRISON TOWNSHIP, LOGAN COUNTY, OHIO
SECTION 15, TOWN 3, RANGE 14, B.T.M.R.S..

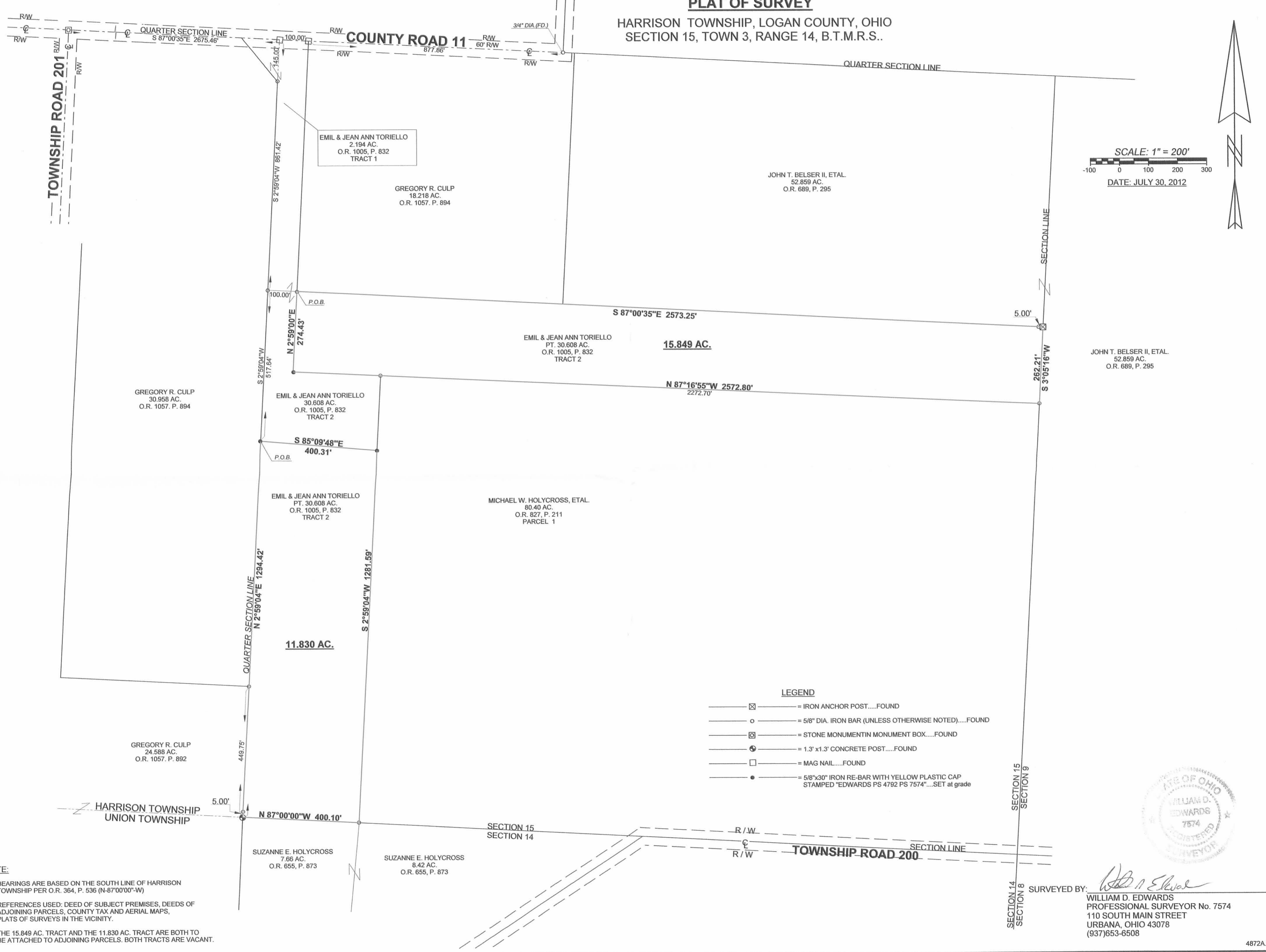

SCALE: 1" = 200'
 -100 0 100 200 300
 DATE: JULY 30, 2012



- LEGEND**
- ⊠ — = IRON ANCHOR POST.....FOUND
 - ○ — = 5/8" DIA. IRON BAR (UNLESS OTHERWISE NOTED).....FOUND
 - ⊡ — = STONE MONUMENT IN MONUMENT BOX.....FOUND
 - ⊙ — = 1.3' x 1.3' CONCRETE POST.....FOUND
 - □ — = MAG NAIL.....FOUND
 - ● — = 5/8"x30" IRON RE-BAR WITH YELLOW PLASTIC CAP STAMPED "EDWARDS PS 4792 PS 7574".....SET at grade



- NOTE:**
1. BEARINGS ARE BASED ON THE SOUTH LINE OF HARRISON TOWNSHIP PER O.R. 364, P. 536 (N-87°00'00"-W)
 2. REFERENCES USED: DEED OF SUBJECT PREMISES, DEEDS OF ADJOINING PARCELS, COUNTY TAX AND AERIAL MAPS, PLATS OF SURVEYS IN THE VICINITY.
 3. THE 15.849 AC. TRACT AND THE 11.830 AC. TRACT ARE BOTH TO BE ATTACHED TO ADJOINING PARCELS. BOTH TRACTS ARE VACANT.

SURVEYED BY: *William D. Edwards*
 WILLIAM D. EDWARDS
 PROFESSIONAL SURVEYOR No. 7574
 110 SOUTH MAIN STREET
 URBANA, OHIO 43078
 (937)653-6508

INDEXED ON MAP
 849 6P