

Plat Cab B Slide 41B

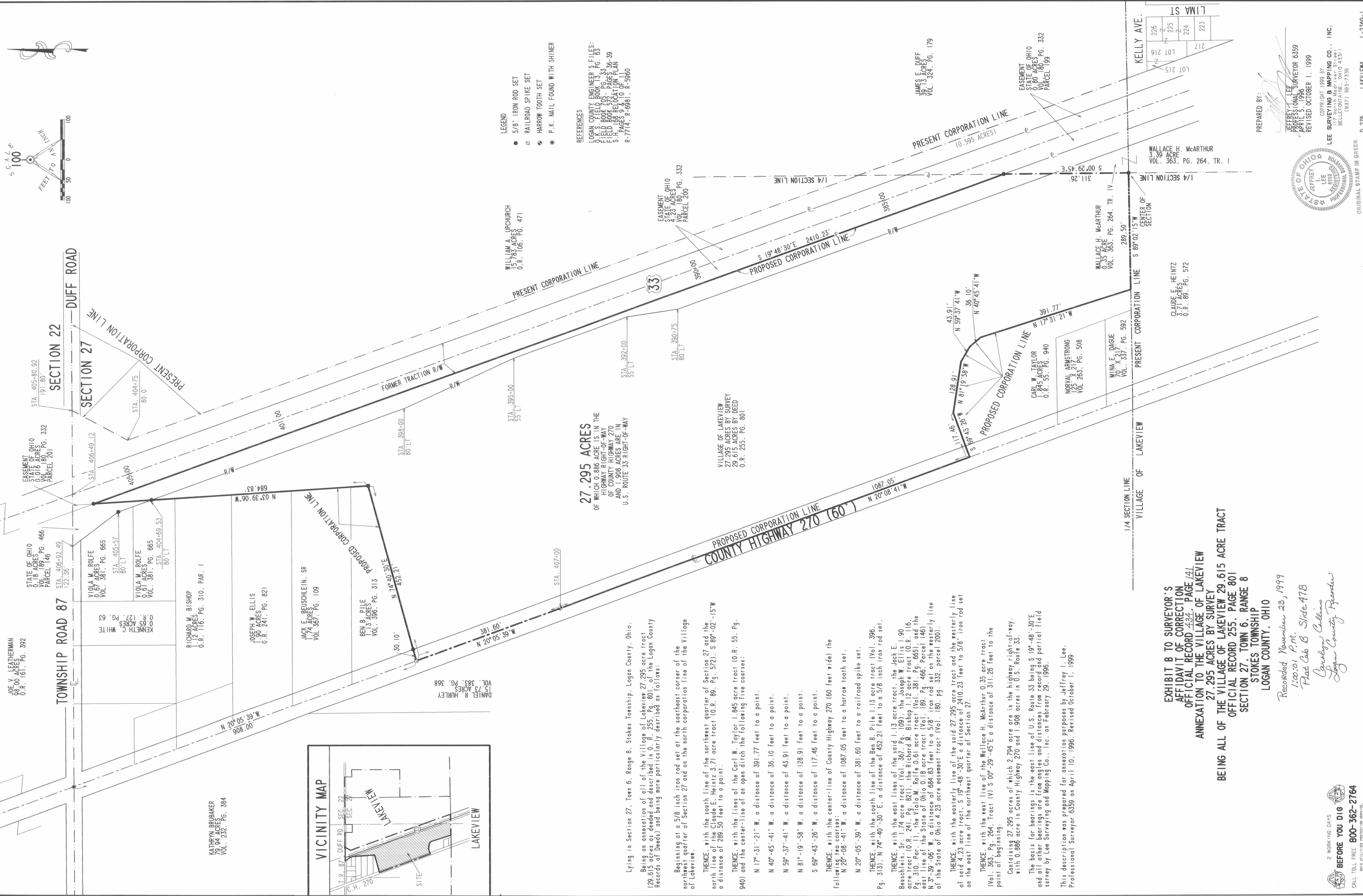

KATHRYN BRUBAKER
79.94 ACRES
VOL. 232, PG. 384

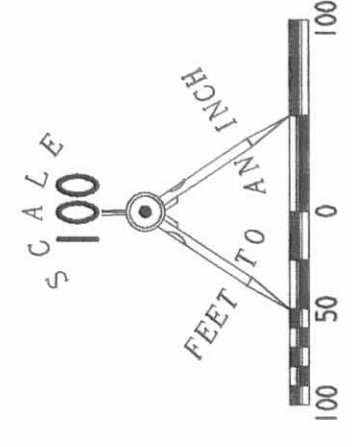
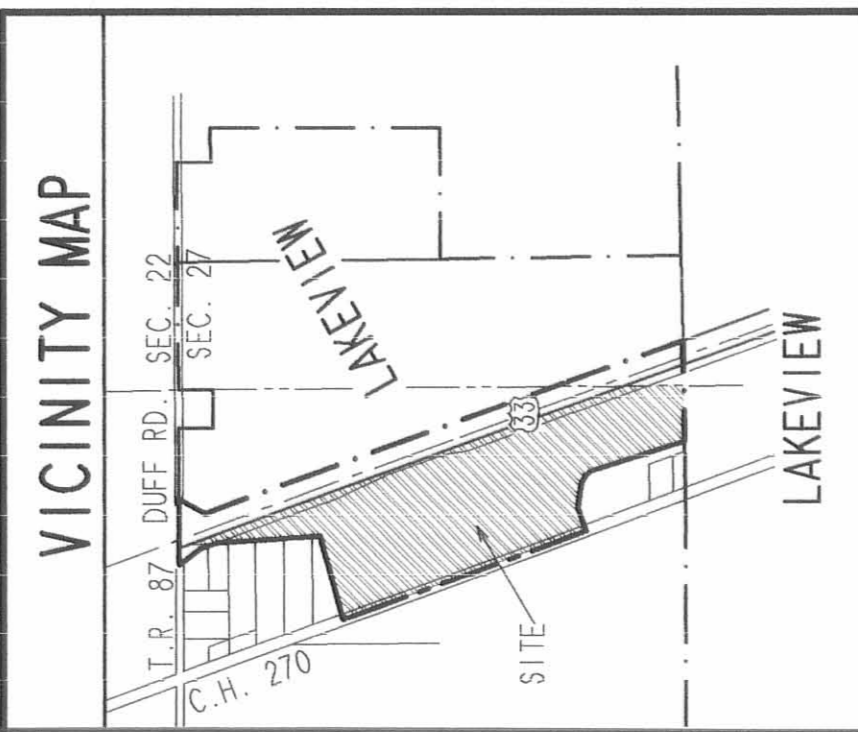

27.295 ACRES
OF WHICH 0.886 ACRE IS IN THE
HIGHWAY RIGHT-OF-WAY
OF COUNTY HIGHWAY 270
AND 1.908 ACRES ARE IN
U.S. ROUTE 33 RIGHT-OF-WAY

Lying in Section 27, Town 6, Range 8, Stokes Township, Logan County, Ohio.

Being an annexation of all of the Village of Lakeview 27.295 acre tract (29.615 acres as deeded and described in O.R. 255, Pg. 801) of the Logan County Records of Deeds) and being more particularly described as follows:

Beginning at a 5/8 inch iron rod set at the southeast corner of the northwest quarter of Section 27 and on the north corporation line of the Village of Lakeview.

THENCE, with the south line of the northwest quarter of Section 27 and the north line of the Claude E. Heintz 3.71 acre tract (O.R. 89, Pg. 572), S 89°-02'-15" W a distance of 289.50 feet to a point.

THENCE, with the lines of the Carl W. Taylor 1.845 acre tract (O.R. 55, Pg. 940) and the center-line of an open ditch the following five courses:

- N 17°-31'-21" W, a distance of 391.77 feet to a point.
- N 40°-45'-41" W, a distance of 36.10 feet to a point.
- N 59°-37'-41" W, a distance of 43.91 feet to a point.
- N 81°-19'-58" W, a distance of 128.91 feet to a point.
- S 69°-43'-26" W, a distance of 117.46 feet to a point.

THENCE, with the center-line of County Highway 270 (60 feet wide) the following two courses:

- N 20°-08'-41" W, a distance of 1087.05 feet to a railroad spike set.
- N 20°-05'-39" W, a distance of 381.60 feet to a railroad spike set.

THENCE, with the south line of the Ben B. Pile, 1.13 acre tract (Vol. 396, Pg. 313), N 74°-40'-30" E, a distance of 452.21 feet to a 5/8 inch iron rod set.

THENCE, with the east lines of the said 1.13 acre tract, the Jack E. Beuschlein, Sr., 1.74 acre tract (Vol. 367, Pg. 109), the Joseph W. Ellis, 1.90 acre tract (O.R. 241, Pg. 821), the Richard M. Bishop 1.12 acre tract (O.R. 116, Pg. 310, Par. 1), the Viola M. Rolfe 0.61 acre tract (Vol. 381, Pg. 665), and the east line of the State of Ohio 0.18 acre tract (Vol. 189, Pg. 466, Parcel 146) N 3°-39'-06" W, a distance of 684.83 feet to a 5/8" iron rod set on the westerly line of the State of Ohio 4.23 acre easement tract (Vol. 180, pg. 332, parcel 200).

THENCE, with the easterly line of the said 27.295 acre tract and the westerly line of said 4.23 acre tract, S 19°-48'-30" E a distance of 2410.23 feet to 5/8" iron rod set on the east line of the northwest quarter of Section 27.

THENCE, with the west line of the Wallace H. McArthur 0.35 acre tract (Vol. 363, Pg. 264, Tract IV) S 00°-29'-45" E a distance of 311.26 feet to the point of beginning.

Containing 27.295 acres of which 2.794 acre are in the highway right-of-way, with 0.886 acre in County Highway 270 and 1.908 acres in U.S. Route 33.

The basis for bearings is the east line of U.S. Route 33 being S 19°-48'-30" E and all other bearings are from angles and distances from record and partial field survey by Lee Surveying and Mapping Co., Inc. on February 29, 1996.

This description was prepared for annexation purposes by Jeffrey L. Lee, Professional Surveyor 6359 on April 10, 1996. Revised October 1, 1999.

EXHIBIT B TO SURVEYOR'S AFFIDAVIT OF CORRECTION OFFICIAL RECORD 434, PAGE 141 ANNEXATION TO THE VILLAGE OF LAKEVIEW

27.295 ACRES BY SURVEY BEING ALL OF THE VILLAGE OF LAKEVIEW 29.615 ACRE TRACT OFFICIAL RECORD 255, PAGE 801 SECTION 27, TOWN 6, RANGE 8 STOKES TOWNSHIP LOGAN COUNTY, OHIO

Recorded November 23, 1999
1:00:01 P.M.

Plat Cab B Slide 41B
Carlynn Collins
Logan County Recorder

2 WORKING DAYS
BEFORE YOU D16
CALL TOLL FREE 800-362-2764
Ohio Not Public for Service



PREPARED BY:
JEFFREY L. LEE
PROFESSIONAL SURVEYOR 6359
ARTICLE 3, 1996
REVISED OCTOBER 1, 1999

CORP. RIGHT 1999 BY:
LEE SURVEYING & MAPPING CO., INC.
117 North McGuffey Street
Bellefontaine, Ohio 45311
(937) 593-7325

ORIGINAL STAMP IN GREEN
D 276
LAKVIEW
L-2369-1